

LECTURE NOTES
ON
FOUNDATION ENGINEERING
6th SEMESTER
Bhabanisankar Sahani
ASST. PROFESSOR
DEPARTMENT OF CIVIL ENGINEERING



GANDHI INSTITUTE OF TECHNOLOGY AND MANAGEMENT(GITAM)

Affiliated to BPUT & SCTE&VT, Govt. of Odisha

Approved by AICTE, New Delhi



MODULE-I

Retaining Wall: Retaining walls are structures that support backfill and allow for a change of grade.

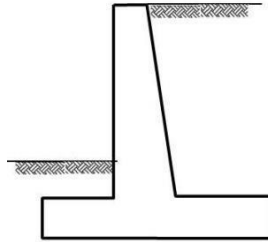

Lateral Earth Pressure

Lateral earth pressure is the force exerted by the soil mass upon an earth-retaining structure, such as a retaining wall. It is of two types –

Active Earth pressure

The soil exerts a push against the wall making the wall to move slightly away from the backfilled soil mass. This kind of pressure is known as the active earth pressure of the soil.

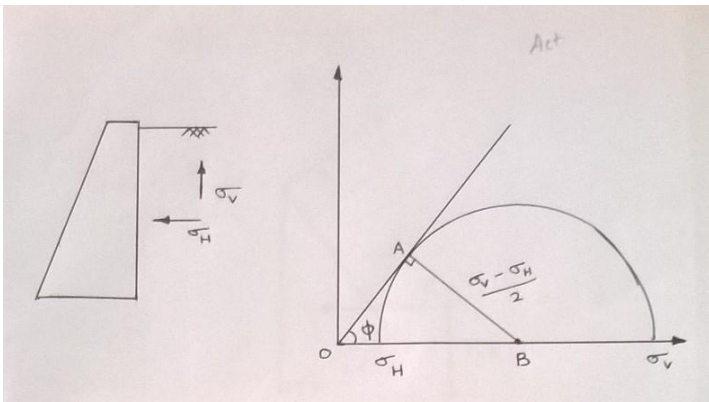

σ_v – Major principal stress σ_H

- Minor principal stress

$$\sin \Phi = \frac{(\sigma_v - \sigma_H) / 2}{(\sigma_v + \sigma_H) / 2}$$

$$(\sigma_v + \sigma_H) \sin \Phi = (\sigma_v - \sigma_H)$$

$$\sigma_v \sin \Phi + \sigma_H \sin \Phi = (\sigma_v - \sigma_H)$$

$$\sigma_H (1 + \sin \Phi) = \sigma_v (1 - \sin \Phi)$$

$$\frac{\sigma_H}{\sigma_V} = K_a = \frac{1 - \sin \phi}{1 + \sin \phi}$$

II Passive earth pressure

The retaining wall is caused to move toward the soil and the soil provides the resistance which soil develops in response to movement of the structure toward it is called the passive earth pressure

$$\sin \Phi = AB/OB$$

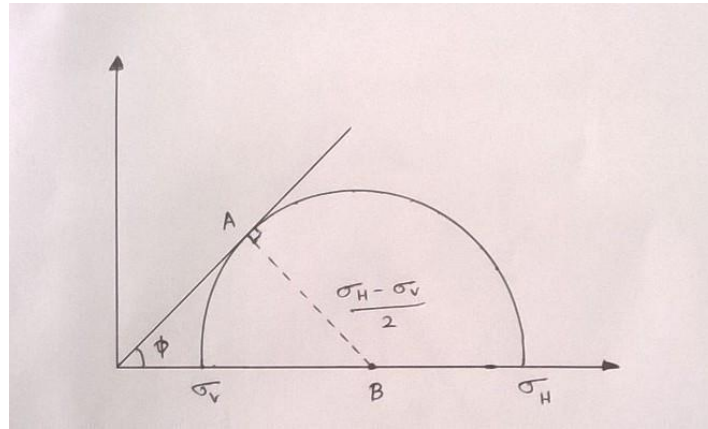

$$\sin \Phi = AB/OB$$

$$\frac{(\sigma_H - \sigma_V)/2}{(\sigma_V + \sigma_H)/2}$$

$$K_p = \frac{1 + \sin \phi}{1 - \sin \phi}$$

$$(\sigma_V + \sigma_H) \sin \Phi = (\sigma_H - \sigma_V)$$

$$\sigma_V \sin \Phi + \sigma_H \sin \Phi = (\sigma_H - \sigma_V)$$

$$\sigma_V (1 + \sin \Phi) = \sigma_H (1 - \sin \Phi)$$

$$\frac{\sigma_H}{\sigma_V} = \frac{1 + \sin \Phi}{1 - \sin \Phi} = K_p =$$

i. III Earth pressure at rest

Neither the soil moves nor wall moves

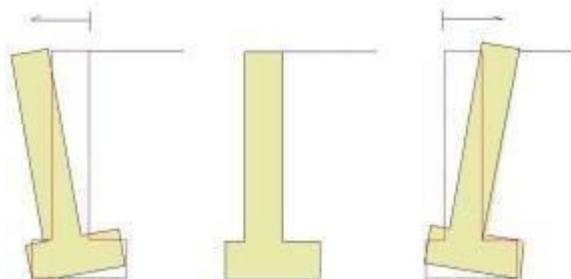

Rankine's Theory:

Assumptions

- 1) The soil mass is semi infinite, homogeneous, dry and cohesionless.
- 2) The ground surface is a plane which may be horizontal or inclined.
- 3) The face of the wall in contact with the backfill is vertical and smooth. In other words, the friction between the wall and the backfill is neglected (This amounts to ignoring the presence of the wall).
- 4) The wall yields about the base sufficiently for the active pressure conditions to develop; if it is the passive case that is under consideration, the wall is taken to be pushed sufficiently towards the fill for the passive resistance to be fall per unit length of the wall, is given by P_a acting at a height of $(1/3)H$

Cohesionless soil

i) Active earth pressure

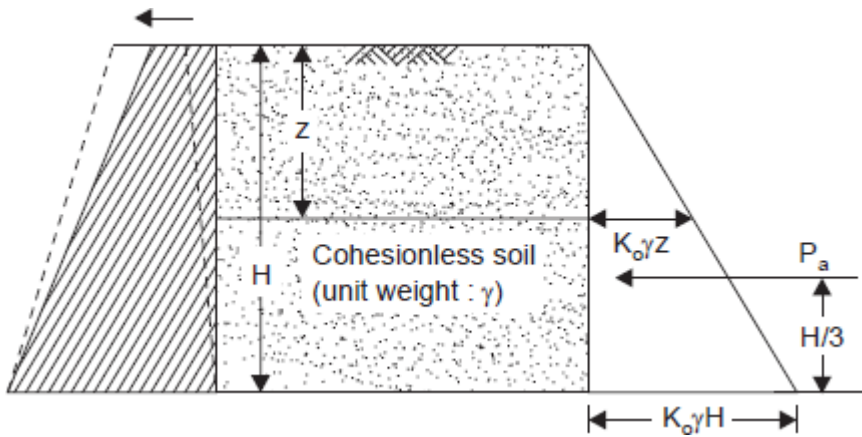

$$P_a = \frac{1}{2} K_a \gamma H^2$$

$$K_a = \frac{1 - \sin \phi}{1 + \sin \phi}$$

For a total height of H of the wall, the total thrust P_a on the wall per unit length of the wall, is given by P_a acting at a height of $(1/3)H$.

ii) Passive earth pressure

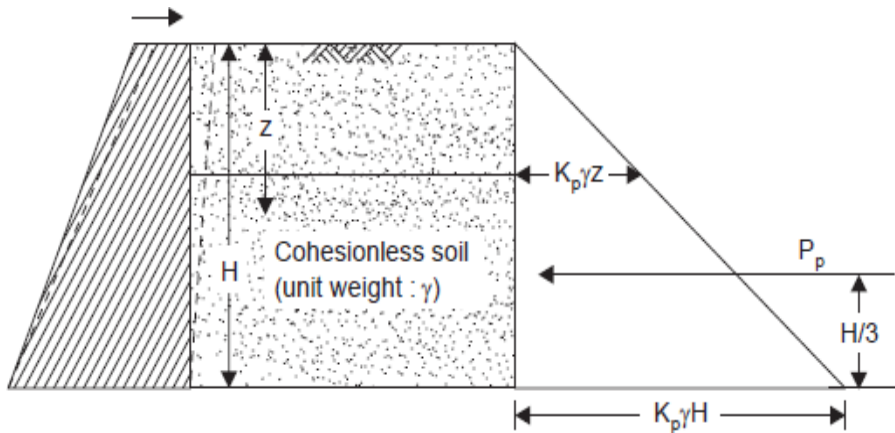

$$P_p = \frac{1}{2} K_p \cdot \gamma \cdot H^2$$

$$K_p = \frac{1 + \sin \phi}{1 - \sin \phi}$$

For a total height of H of the wall, the total thrust P_a on the wall per unit length of the wall, is given by P_p acting at a height of $(1/3)H$.

Effect of Submergence

Under submerge or saturated condition, the lateral earth pressure will due to –

- Lateral earth pressure due to submerged unit weight of the backfill soil
- Lateral pressure due to pore water

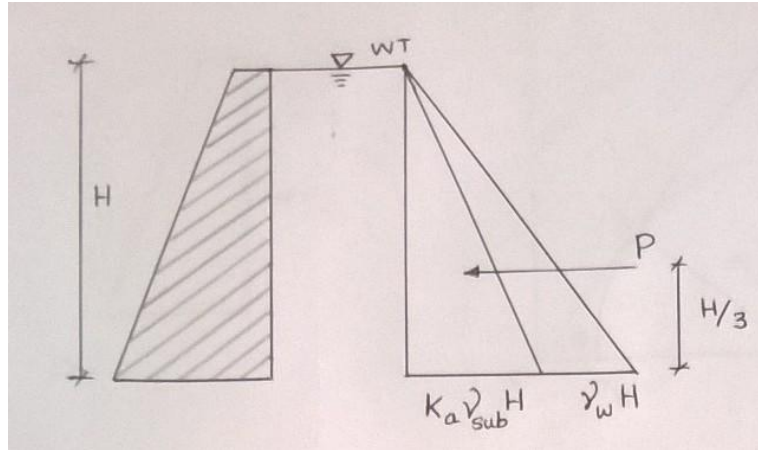

$$\begin{aligned} \text{Lateral pressure at base of wall} &= K_a \gamma' H + \gamma_w H \\ \gamma' &= \gamma_{sat} - \gamma_w \\ \text{Total active thrust, } P &= \frac{1}{2} (K_a \gamma' H + \gamma_w H) \times H \end{aligned}$$

Effect of partial submergence

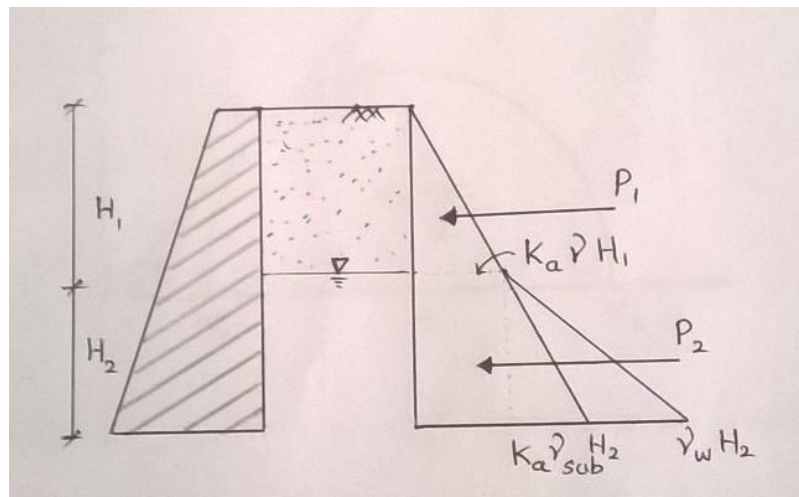

$$\begin{aligned} H_1 &= \text{depth of submerged fill,} \\ K_a &= \text{active earth pressure coefficient,} \end{aligned}$$

H_2 = depth of fill above water table (taken to be moist),
 γ = moist unit weight, and
 γ' or γ_{sub} = submerged or effective unit weight

Lateral pressure at base of wall = $K_a \gamma' H_2 + K_a \gamma H_1 + \gamma_w H_2$

$P_1 = \frac{1}{2} \times (K_a \gamma H_1) \times H_1$

$P_2 = [(K_a \gamma H_1 \times H_2)] + [\frac{1}{2} \times (K_a \gamma' H_2 + \gamma_w H_2) \times H_2]$

Total thrust, $P = P_1 + P_2$

Acting at a distance of $x = [P_1 \times (H_2 + \frac{H_1}{3}) + (P_2 \times \frac{H_2}{3})] / [P_1 + P_2]$ from the base

Effect of uniform surcharge

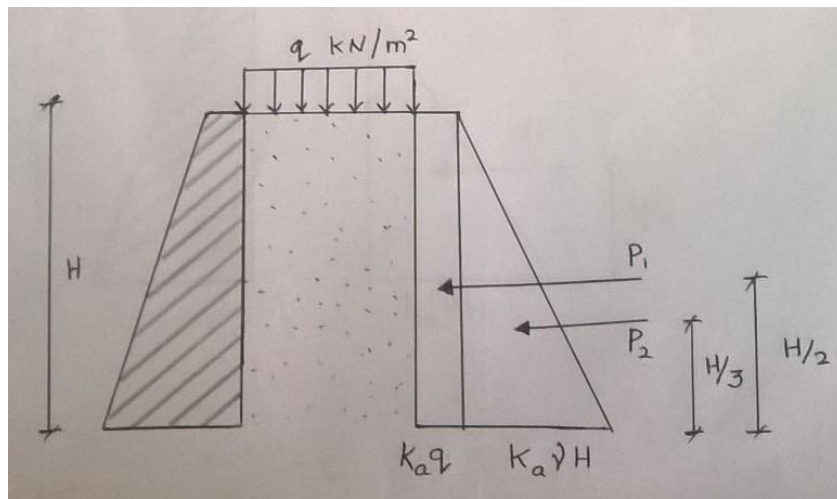

q = Uniform surcharge

$P_1 = K_a q H$

$P_2 = \frac{1}{2} \times K_a \gamma H \times H = \frac{1}{2} K_a \gamma H^2$

Total thrust = $P_1 + P_2$

Acting at a distance of $x = [(P_1 \times \frac{H}{2}) + (P_2 \times \frac{H}{3})] / [P_1 + P_2]$ from the base

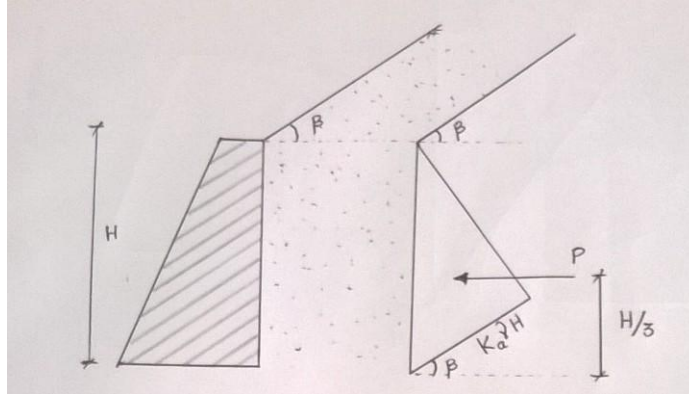

Effect of inclined submergence

$$K_a = \cos \beta \left(\frac{\cos \beta - \sqrt{\cos^2 \beta - \cos^2 \phi}}{\cos \beta + \sqrt{\cos^2 \beta - \cos^2 \phi}} \right)$$

$$K_p = \cos \beta \left(\frac{\cos \beta + \sqrt{\cos^2 \beta - \cos^2 \phi}}{\cos \beta - \sqrt{\cos^2 \beta - \cos^2 \phi}} \right)$$

$$\text{Total thrust, } P = \frac{1}{2} \times K_a \times H \times H = \frac{1}{2} K_a H^2$$

□ H^2 Problem:

1. A retaining wall 4m height has a smooth vertical back. The backfill has horizontal surface in level with top of wall. The unit weight of back fill is 18 kN/m^3 and the angle of shear resistance is 30° . The cohesion is zero. Determine –

- the magnitude of earth pressure per meter run and the point of application
- when the water table is at top with saturated unit weight of 18 kN/m^3
- when the retaining wall has the surcharge of 36 kN/m^2 with unit weight of 18 kN/m^3

Given

$$H = 4\text{m}$$

$$\gamma = 18 \text{ kN/m}^3$$

$$\Phi = 30^\circ$$

$$K_a = \frac{1 - \sin \Phi}{1 + \sin \Phi} = 1/3$$

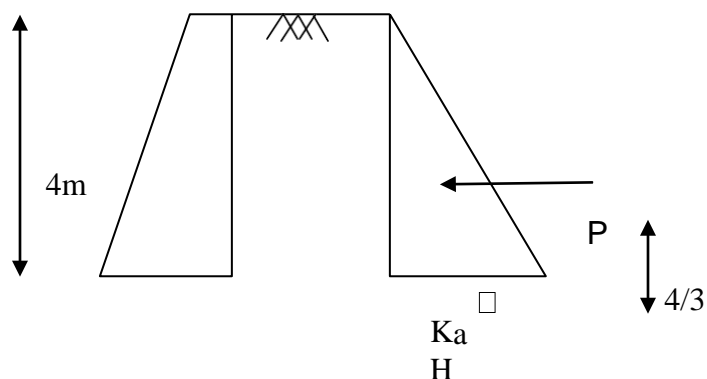

$$\text{Earth pressure at top} = 0$$

$$\text{Earth pressure at bottom} = K_a \rho H = (1/3) \times 18 \times 4 = 24 \text{ kN/m}^2$$

$$P = \frac{1}{2} \times (K_a \rho H) \times H$$

$$= 0.5 \times 24 \times 4$$

$$= 48 \text{ kN/m}$$

$$H/3 = 4/3 = 1.33\text{m}$$

Hence earth pressure of 48 kN/m is acting at height of 1.33m from the bottom

ii. Water table at top:

$$\rho_s t = 18 \text{ kN/m}^3$$

$$\rho_{\text{sub}} = \rho_s t - \rho_w = 18 - 9.8 = 8.2 \text{ kN/m}^3$$

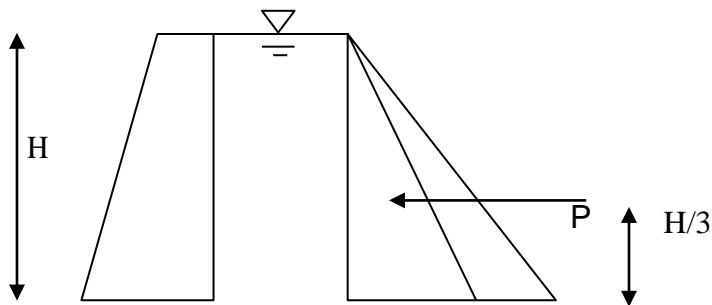

$$K_a \rho_{\text{sub}} H + \rho_w H$$

$$K_a = 1/3$$

$$\text{Earth pressure at top} = 0$$

$$\text{Earth pressure at bottom} = K_a \rho_{\text{sub}} H + \rho_w H$$

$$= [(1/3) \times 8.2 \times 4] + [9.8 \times 4]$$

$$= 50.13 \text{ kN/m}^2$$

$$P = (1/2) \times (K_a \rho_{\text{sub}} H + \rho_w H) \times H$$

$$= (1/2) \times 50.13 \times 4$$

$$= 100.26 \text{ kN/m}$$

$$H/3 = 4/3 = 1.33\text{m}$$

Hence earth pressure of 100.26 kN/m is acting at height of 1.33m from the bottom

iii. Retaining wall has the surcharge of 36kN/m^2 with unit weight of 18kN/m^3

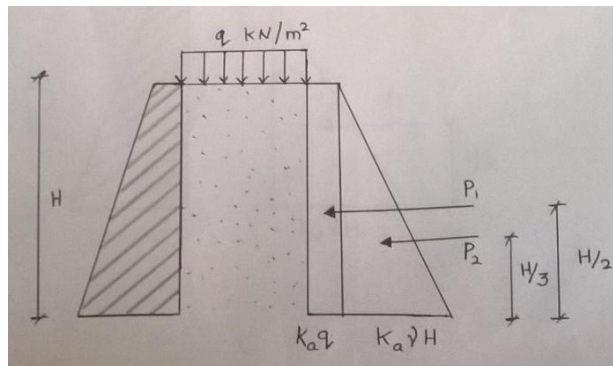

$$q = 36\text{kN/m}^2$$

$$K_a = 1/3$$

$$\text{Earth pressure at top} = K_a \times q = (1/3) \times 36 = 12\text{ kN/m}^2$$

$$\text{Earth pressure at bottom} = K_a q + K_a \gamma H$$

$$= [(1/3) \times 36] + [(1/3) \times 18 \times 4]$$

$$= 36\text{ kN/m}^2$$

$$P_1 = K_a q H = 12 \times 4 = 48\text{ kN/m}$$

$$H/2 = 4/2 = 2\text{m}$$

Earth pressure of 48 kN/m is acting at height of 2m from bottom

$$P_2 = \frac{1}{2} K_a \gamma H^2 = (1/2) \times 24 \times 4 = 48\text{ kN/m}$$

$$H/3 = 4/3 = 1.33\text{m}$$

Earth pressure of 48 kN/m is acting at a height of 1.33m from the bottom Total

$$\text{thrust, } P = P_1 + P_2 = 48 + 48 = 96\text{ kN/m}$$

$$x = [(P_1 \times \frac{H}{2}) + (P_2 \times \frac{H}{3})] / [P_1 + P_2]$$

$$= [(48 \times 2) + (48 \times 1.33)] / 96$$

$$= 1.66\text{m}$$

Total earth pressure of 96kN/m is acting at a height of 1.66m from the bottom

Coulomb's wedge theory:

- Coulomb's theory considers the soil behind the wall as a whole instead of as an element in the soil. If a wall supporting a granular soil were not to be there, the soil will slump down to its angle of repose or internal friction.
- It is therefore reasonable to assume that if the wall only moved forward slightly a rupture plane would develop somewhere between the wall and the surface of repose.
- The triangular mass of soil between this plane of failure and the back of the wall is referred to as the 'sliding wedge'.
- It is reasoned that, if the retaining wall were suddenly removed, the soil within the sliding wedge would slump downward.
- Therefore, an analysis of the forces acting on the sliding wedge at incipient failure will reveal the thrust from the lateral earth pressure which is necessary for the wall to withstand in order to hold the soil mass in place.
- However, Coulomb recognised the possibility of the existence of a curved rupture surface, although he considered a plane surface for the sake of mathematical simplicity.

Assumptions:

1. The soil is isotropic and homogenous
2. The surface of rupture is plane
3. The failure wedge is a rigid body
4. There is a friction between wall and the back fill soil and is known as 'wall friction'
5. Back of wall need not be vertical
6. Failure is two dimensional
7. The soil is cohesionless
8. Coulomb's equation of shear strength is valid

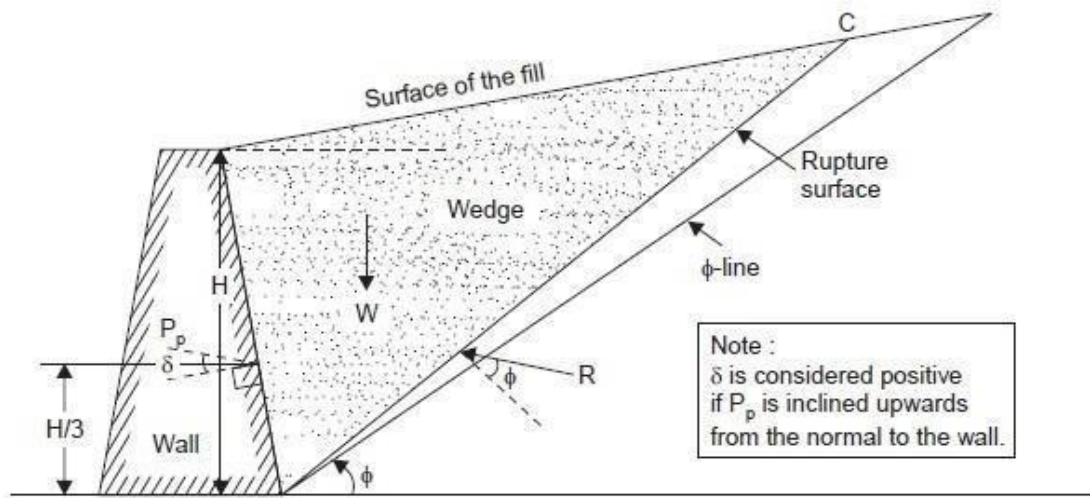

(b) Passive earth resistance

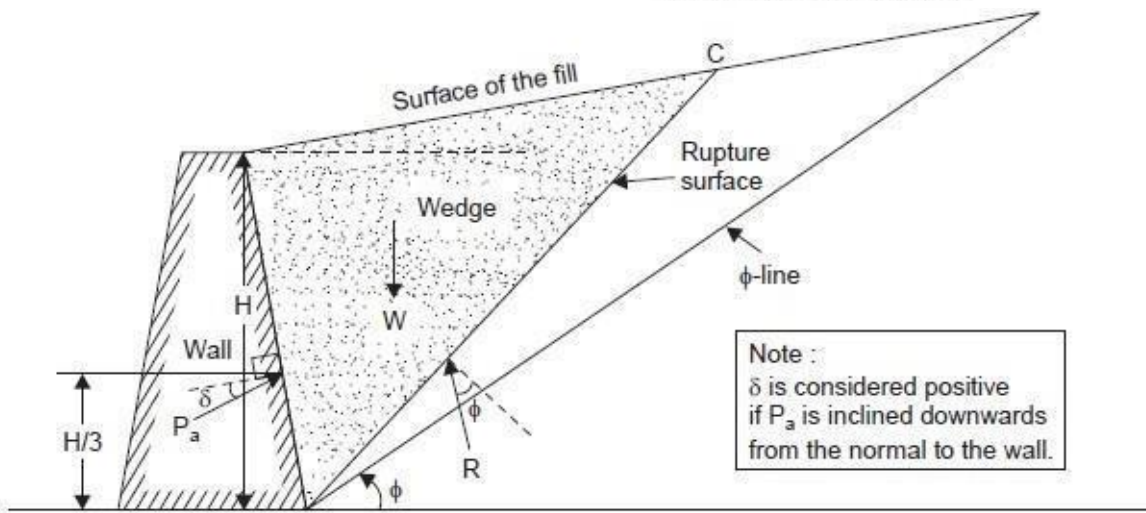

(a) Active earth pressure

Limitations:

Coulomb's theory is applicable –

to inclined wall faces

to a wall with a broken face

to a sloping backfill curved backfill surface, broken backfill surface

to concentrated or distributed surcharge loads.

One of the main deficiencies in Coulomb's theory is that, in general, it does not satisfy the static equilibrium condition occurring in nature.

The three forces (weight of the sliding wedge, earth pressure and soil reaction on the rupture surface) acting on the sliding wedge do not meet at a common point, when the sliding surface is assumed to be planar.

Even the wall friction was not originally considered but was introduced only some time later.

Active earth pressure of cohesionless soil:

A simple case of active earth pressure on an inclined wall face with a uniformly sloping backfill may be considered first. The backfill consists of homogeneous, elastic and isotropic cohesionless soil. A unit length of the wall perpendicular to the plane of the paper is considered.

The forces acting on the sliding wedge are

- (i) W, weight of the soil contained in the sliding wedge,
- (ii) R, the soil reaction across the plane of sliding,
- (iii) the active thrust Pa against the wall

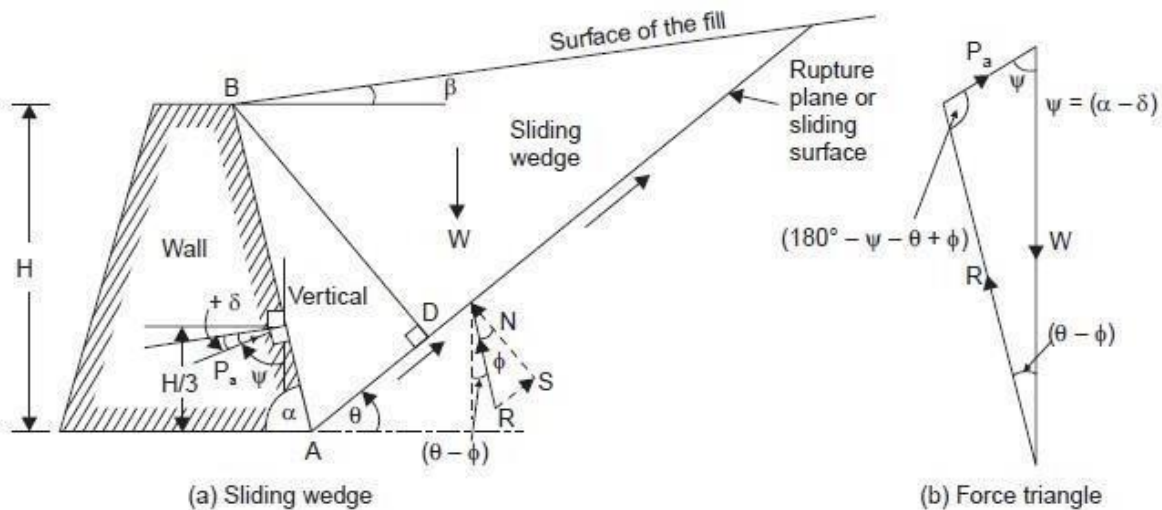

$$P_a = \frac{1}{2} \gamma H^2 \cdot K_a,$$

Where,

$$K_a = \frac{\sin^2(\alpha + \phi)}{\sin^2 \alpha \cdot \sin(\alpha - \delta) \left[1 + \sqrt{\frac{\sin(\phi + \delta) \cdot \sin(\phi - \beta)}{\sin(\alpha - \delta) \sin(\alpha + \beta)}} \right]^2}$$

For a vertical retaining wall a horizontal backfill for which the angle of wall friction = $\delta = 0^\circ$

Hence, substitute $\alpha = 90^\circ$, $\beta = 0^\circ$ and $\delta = 0^\circ$

$$K_a = \frac{\cos \phi}{(1 + \sqrt{2} \sin \phi)^2}$$

Where,

$$K_a = \frac{\sin^2(\alpha + \phi)}{\sin^2 \alpha \cdot \sin(\alpha - \delta) \left[1 + \sqrt{\frac{\sin(\phi + \delta) \cdot \sin(\phi - \beta)}{\sin(\alpha - \delta) \sin(\alpha + \beta)}} \right]^2}$$

For a vertical retaining wall a horizontal backfill for which the angle of wall friction = $\delta = 0^\circ$

Hence, substitute $\alpha = 90^\circ$, $\beta = 0^\circ$ and $\delta = 0^\circ$

$$K_a = \frac{\cos \phi}{(1 + \sqrt{2} \sin \phi)^2}$$

For a smooth vertical retaining wall a backfill with horizontal surface, $\delta = 0^\circ$ and $\beta = 0^\circ$

Hence, $\alpha = 90^\circ$

$$K_a = \frac{1 - \sin \phi}{1 + \sin \phi} = \tan^2 (45^\circ - \phi/2) = 1/N_\phi$$

Passive earth pressure of cohesionless soil:

The passive case differs from the active case in that the obliquity angles at the wall and on the failure plane are of opposite sign.

Plane failure surface is assumed for the passive case also in the Coulomb theory but the critical plane is that for which the passive thrust is minimum. The failure plane is at a much smaller angle to the horizontal than in the active case

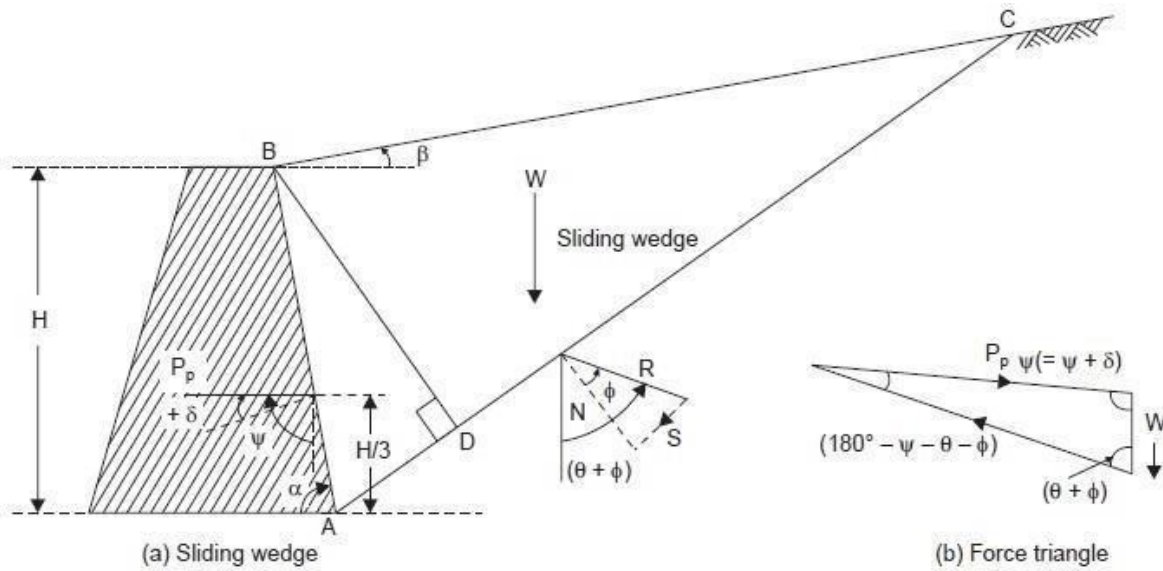

$$P_p = \frac{1}{2} \gamma H^2 \cdot K_p$$

Where,

$$K_p = \frac{\sin^2(\alpha - \phi)}{\sin^2 \alpha \cdot \sin(\alpha + \delta) \left[1 - \frac{\sin(\theta + \delta) \cdot \sin(\phi + \beta)}{\sin(\alpha + \delta) \cdot \sin(\alpha + \beta)} \right]^2}$$

For a vertical retaining wall a horizontal backfill for which the angle of wall friction = ϕ

Hence, substitute $\alpha = 90^\circ$, $\delta = 0^\circ$ and $\beta = \phi$

$$K_p = \frac{\cos^2 \phi}{\cos \phi \left[1 - \sqrt{\frac{2 \sin \phi \cos \phi \cdot \sin \phi}{\cos \phi}} \right]^2} \quad (\text{or})$$

For a smooth horizontal surface, $\phi = 0$

$\phi = 0$. Hence,

$$K_p = \frac{\cos^2 \phi}{(1 - \sin \phi)^2} = \frac{1 - \sin^2 \phi}{(1 - \sin \phi)^2} = \frac{(1 + \sin \phi)}{(1 - \sin \phi)} = \tan^2(45^\circ + \phi/2) = N_\phi,$$

$$K_p = \frac{\cos \phi}{(1 - \sqrt{2} \sin \phi)^2}$$

Culmann's graphical method:

Culmann's method permits one to determine graphically the magnitude of the earth pressure and to locate the most dangerous rupture surface according to Coulomb's wedge theory. **Active earth pressure:**

From the figure, the force triangle may be imagined to be rotated clockwise through an angle $(90^\circ - \phi)$, so as to bring the vector W , parallel to the ϕ -line; in that case, the reaction, R , will be parallel to the rupture surface, and the active thrust, P , parallel to the ψ -line (pressure line).

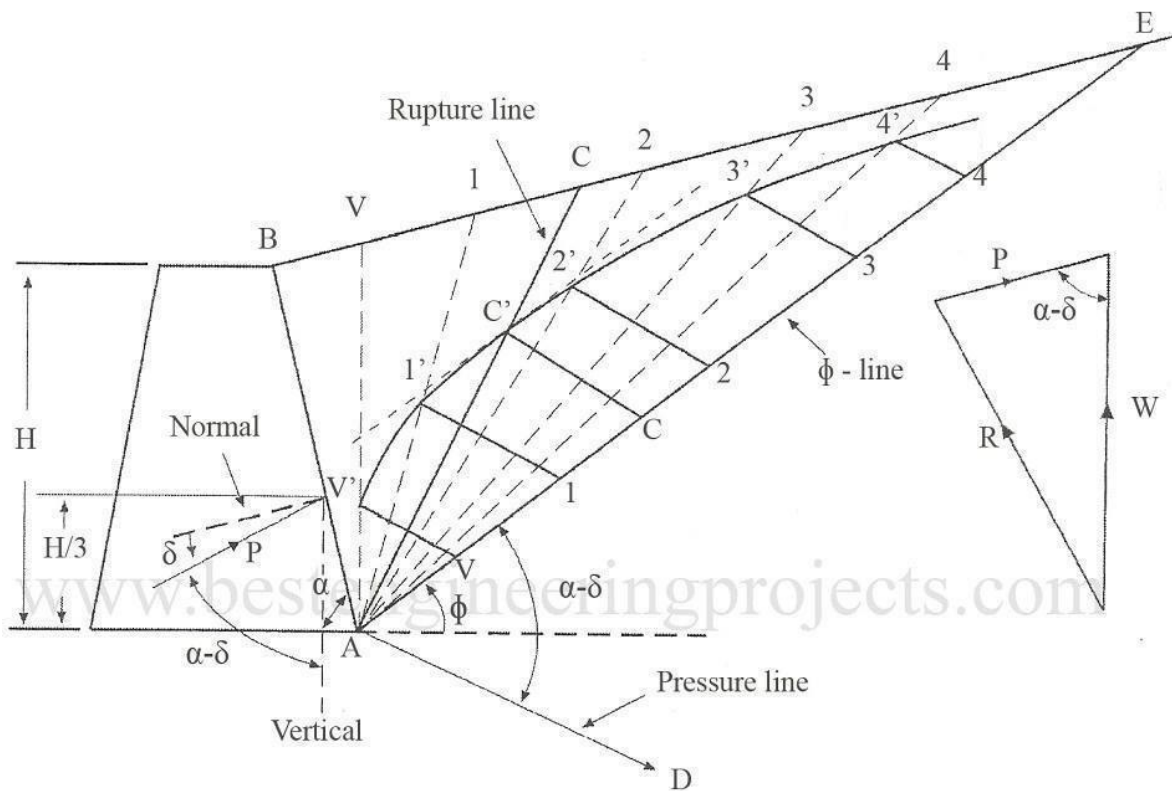

Fig 1 Culmann's Graphical Construction Active Case

The Various steps in the procedure are:

1. Draw Φ -line AE at an angle Φ with the horizontal.
2. Choose an arbitrary failure plane AV. Calculate weight of the wedge ABV and plot it as AV to a convenient scale on the ϕ -line
3. Similarly lay off on AE distances A1, A2, A3 etc to a suitable scale to represent the weight of wedges AB1, AB2, AB3, and so on.
4. Lay off AD at an angle equal to $(\alpha - \delta)$ to the line AE. The line AD is called pressure line.
5. Draw lines parallel to AD from points V, 1, 2, 3 to intersect the assumed lines AV, A1, A2, A3 at points V', 1', 2', 3' etc respectively.
6. Join points V', 1', 2', 3' etc by a smooth curve which is the pressure locus.
7. Select the point C' on pressure locus such that the tangent to the curve is parallel to Φ the - line AE.
8. Draw CC' parallel to the pressure line AD. The magnitude of CC' in its natural units gives the active pressure Pa.
9. Join AC' and produce to meet the surface of the backfill at C. AC is the ruptureline.

Passive earth pressure:

The ϕ -line is to be drawn through point B at an angle $-(\phi)$, i.e., it must be drawn at an angle ϕ below the horizontal. On the line, the weights of the arbitrarily assumed sliding wedges are plotted to a convenient force scale. The position line is drawn through A at an angle $-(\phi + \delta)$ (or to the left of the back face AB of the wall).

The Various steps in the procedure are

1. Draw Φ -line AE at an angle Φ below the horizontal.
2. Lay off on AE distances A2, A3, A4 etc to a suitable scale to represent the weight of wedges AB2, AB3, AB4, and so on.
3. Lay off AD at an angle equal to $(\alpha + \delta)$ to the line AE. The line AD is called pressure line.
4. Draw lines parallel to AD from points, 2, 3, 4 etc to intersect the weight vectors A2, A3, A4 at points 2', 3', 4' etc respectively.
5. Join points, 2', 3', 4' etc by a smooth curve which is the pressure locus.
6. Select the point C' on pressure locus curve such that the line tangent to the curve is parallel to Φ -line AE.
7. Draw CC' parallel to the pressure line AD. The magnitude of CC' in its natural units gives the passive pressure P_p .
8. Join AC'. The line cuts the surface of the backfill at C. The line AC is the rupture line.

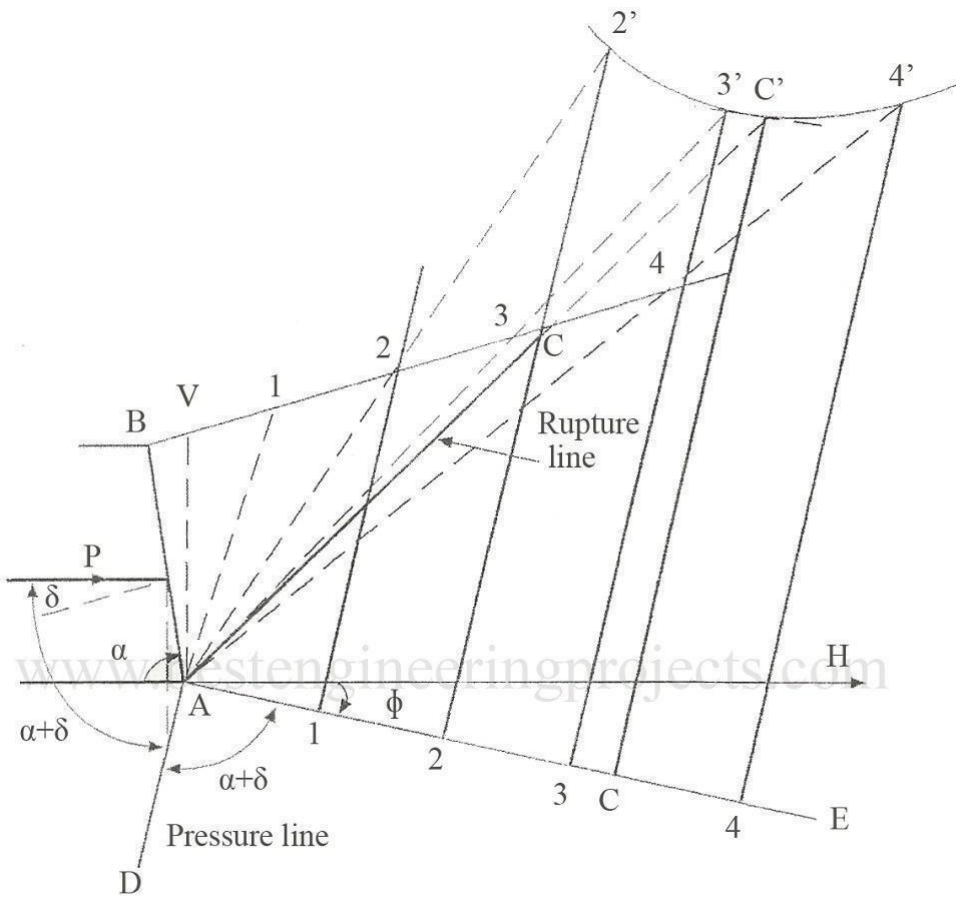

Fig 1 Culmann's Graphical Construction Passive Case

90°,

0° and

MODULE II

BEARING CAPACITY OF SOIL

Bearing capacity is the power of foundation soil to hold the forces from the superstructure without undergoing shear failure or excessive settlement. Foundation soil is that portion of ground which is subjected to additional stresses when foundation and superstructure are constructed on the ground. The following are a few important terminologies related to bearing capacity of soil.

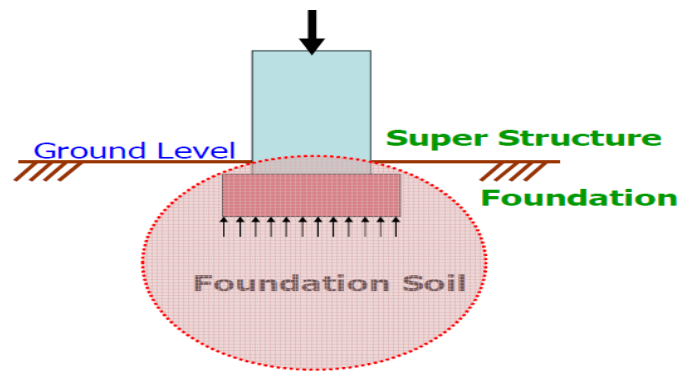

Ultimate Bearing Capacity (q_f) : It is the maximum pressure that a foundation soil can withstand without undergoing shear failure.

Net ultimate Bearing Capacity (q_n) : It is the maximum extra pressure (in addition to initial overburden pressure) that a foundation soil can withstand without undergoing shear failure.

$$q_n = q_f - q_o$$

Here, q_o represents the overburden pressure at foundation level and is equal to γD for level ground without surcharge where the unit weight of soil is γ and D is the depth to foundation bottom from Ground Level.

Safe Bearing Capacity (q_s): It is the safe extra load the foundation soil is subjected to in addition to initial overburden pressure.

Allowable Bearing Pressure (q_a) : It is the maximum pressure the foundation soil is subjected to considering both shear failure and settlement

Foundation is that part of the structure which is in direct contact with soil. Foundation transfers the forces and moments from the super structure to the soil below such that the stresses in soil are within permissible limits and it provides stability against sliding and overturning to the super structure. It is a transition between the super structure and foundation soil. The job of a geotechnical engineer is to ensure that both foundation and soil below are safe against failure and do not experience excessive settlement. Footing and foundation are synonymous.

Modes of shear failure

Depending on the stiffness of foundation soil and depth of foundation, the following are the modes of shear failure experienced by the foundation soil.

General shear failure

Local shear failure

Punching shear failure

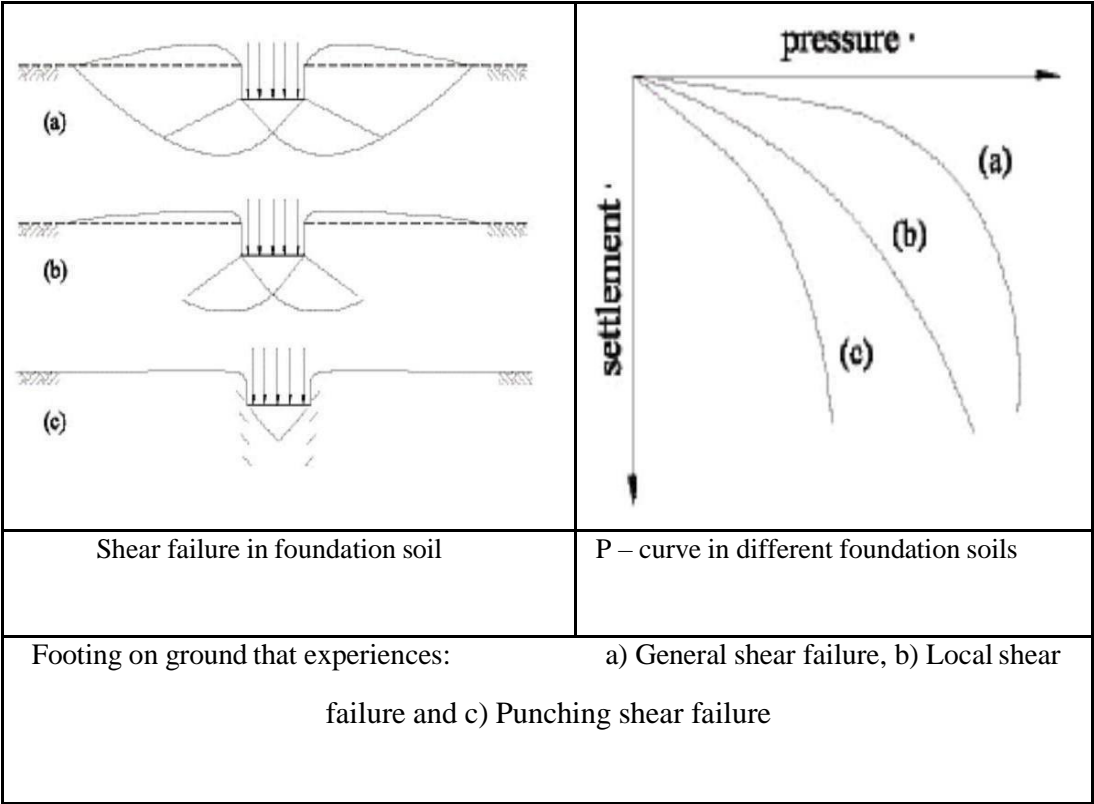

General Shear Failure

This type of failure is seen in dense and stiff soil. The following are some characteristics of general shear failure.

1. Continuous, well defined and distinct failure surface develops between the edge of footing and ground surface.
2. Dense or stiff soil that undergoes low compressibility experiences this failure.
4. Continuous bulging of shear mass adjacent to footing is visible.
5. Failure is accompanied by tilting of footing.
6. Failure is sudden and catastrophic with pronounced peak in P – curve.
7. The length of disturbance beyond the edge of footing is large.
8. State of plastic equilibrium is reached initially at the footing edge and spreads gradually downwards and outwards.
9. General shear failure is accompanied by low strain (<5%) in a soil with considerable ($>36^\circ$) and large N ($N > 30$) having high relative density ($I_D > 70\%$).

Local Shear Failure

This type of failure is seen in relatively loose and soft soil. The following are some characteristics of general shear failure.

1. A significant compression of soil below the footing and partial development of plastic equilibrium is observed.
2. Failure is not sudden and there is no tilting of footing.
3. Failure surface does not reach the ground surface and slight bulging of soil around the footing is observed.
4. Failure surface is not well defined.
5. Failure is characterized by considerable settlement.
6. Well defined peak is absent in P – curve.
7. Local shear failure is accompanied by large strain (> 10 to 20%) in a soil with considerably low ($<28^\circ$) and low N ($N < 5$) having low relative density ($I_D > 20\%$).

Punching Shear Failure

This type of failure is seen in loose and soft soil and at deeper elevations. The following are some characteristics of general shear failure.

This type of failure occurs in a soil of very high compressibility.

1. Failure pattern is not observed.
2. Bulging of soil around the footing is absent.
3. Failure is characterized by very large settlement.
4. Continuous settlement with no increase in P is observed in P – curve.

The below figure presents the conditions for different failure modes in sandy soil carrying circular footing based on the contributions from Vesic (1963 & 1973)

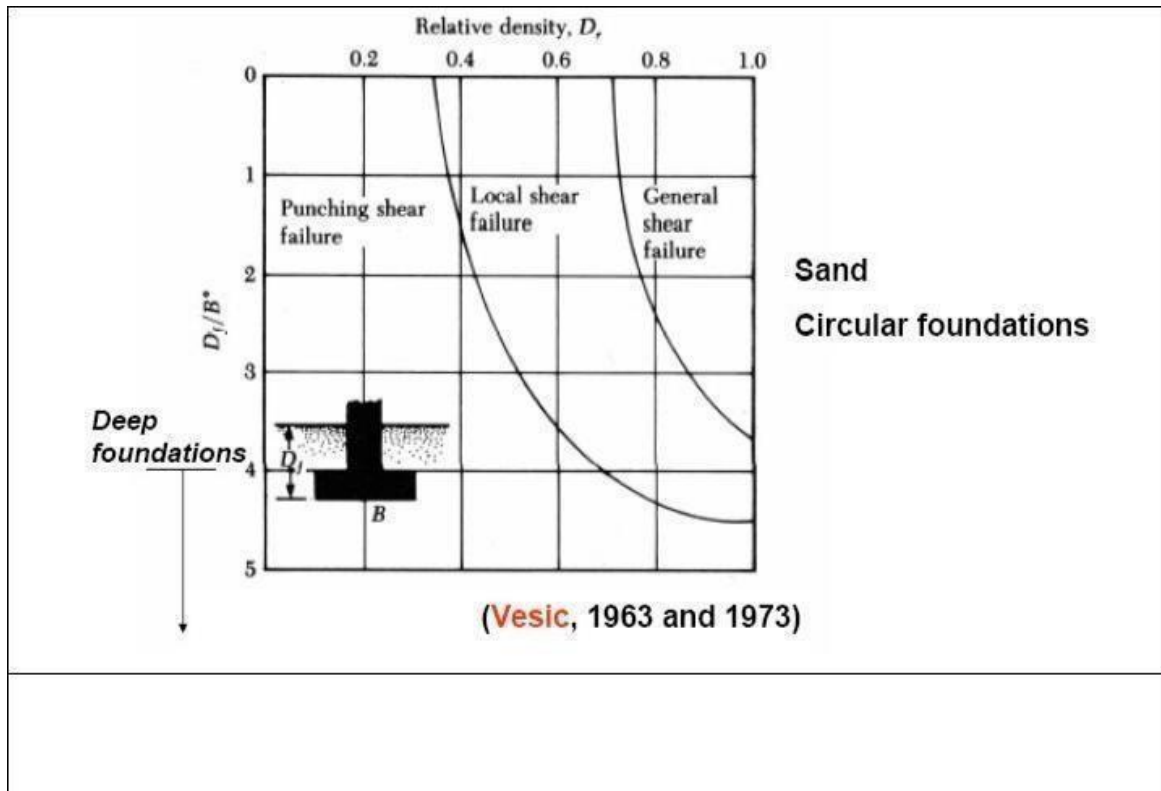

Distinction between General Shear & Local or Punching Shear Failures

The basic distinctions between general shear failure and punching shear failure are presented in Table.

Distinction between General Shear & Local Shear Failures

<u>General Shear Failure</u>	<u>Local/Punching Shear Failure</u>
Occurs in dense/stiff soil $>36^\circ$, $N > 30$, $I_D > 70\%$, $C_u > 100$ kPa	Occurs in loose/soft soil $<28^\circ$, $N < 5$, $I_D < 20\%$, $C_u < 50$ kPa
Results in small strain ($<5\%$)	Results in large strain ($>20\%$)
Failure pattern well defined & clear	Failure pattern not well defined
Well defined peak in P- curve	No peak in P- curve
Bulging formed in the neighbourhood of footing at the surface	No Bulging observed in the neighbourhood of footing
Extent of horizontal spread of disturbance at the surface large	Extent of horizontal spread of disturbance at the surface very small
Observed in shallow foundations	Observed in deep foundations
Failure is sudden & catastrophic	Failure is gradual
Less settlement, but tilting failure observed	Considerable settlement of footing Observed

Terzaghi's bearing Capacity Theory

Terzaghi (1943) was the first to propose a comprehensive theory for evaluating the safe bearing capacity of shallow foundation with rough base.

Assumptions

1. Soil is homogeneous and Isotropic.
2. The shear strength of soil is represented by Mohr Coulombs Criteria.
3. The footing is of strip footing type with rough base. It is essentially a two dimensional plane strain problem.
4. Elastic zone has straight boundaries inclined at an angle equal to the horizontal.
5. Failure zone is not extended above, beyond the base of the footing. Shear resistance of soil above the base of footing is neglected.
6. Method of superposition is valid.
7. Passive pressure force has three components (P_{PC} produced by cohesion, P_{Pq} produced by surcharge and P_P produced by weight of shear zone).
8. Effect of water table is neglected.

Footing carries concentric and vertical loads.

1. Footing and ground are horizontal.
2. Limit equilibrium is reached simultaneously at all points. Complete shear failure is mobilized at all points at the same time.
3. The properties of foundation soil do not change during the shear failure

Limitations

1. The theory is applicable to shallow foundations
2. As the soil compresses, increases which is not considered. Hence fully plastic zone may not develop at the assumed.

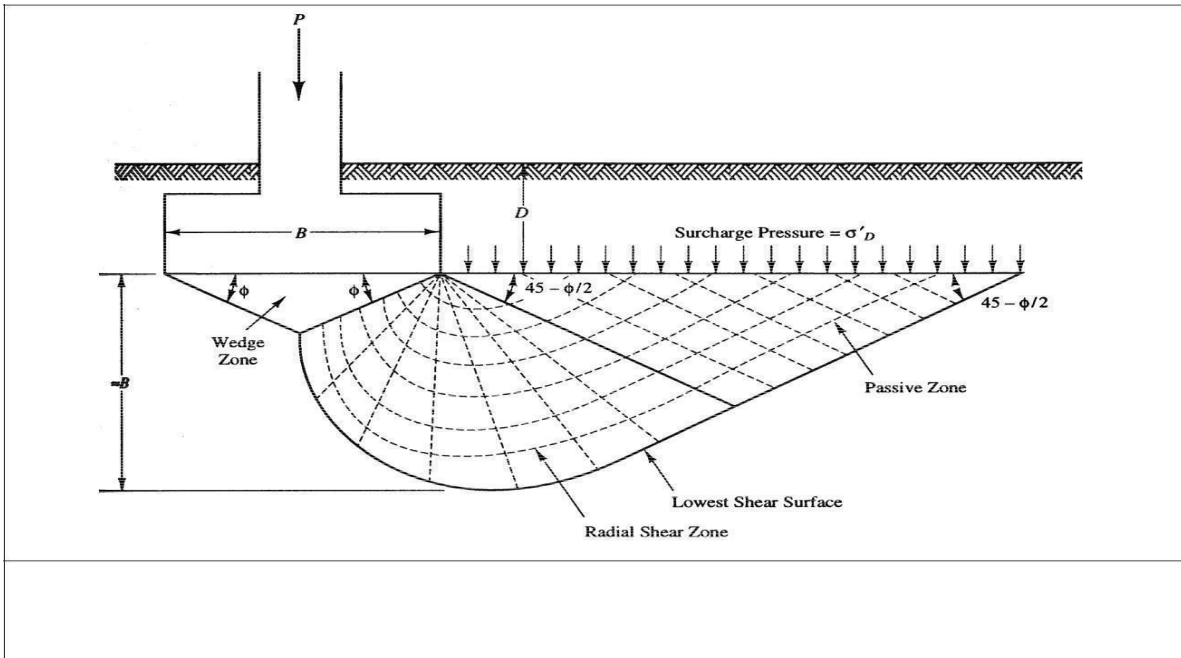

3. All points need not experience limit equilibrium condition at different loads.
4. Method of superposition is not acceptable in plastic conditions as the ground is near failure zone.

A strip footing of width B gradually compresses the foundation soil underneath due to the vertical load from superstructure. Let q_f be the final load at which the foundation soil experiences failure due to the mobilization of plastic equilibrium. The foundation soil fails along the composite failure surface and the region is divided into five zones, Zone 1 which is elastic, two numbers of Zone 2 which are the zones of radial shear and two zones of Zone 3 which are the zones of linear shear. Considering horizontal force equilibrium and incorporating empirical relation, the equation for ultimate bearing capacity is obtained as follows.

Ultimate bearing capacity,

$$q_f = cN_c + \gamma DN_q + 0.5\gamma BN\gamma$$

If the ground is subjected to additional surcharge load q , then

$$q_f = cN_c + (\gamma D + q)N_q + 0.5\gamma BN\gamma$$

Net ultimate bearing capacity,

$$q_n = cN_c + \gamma DN_q + 0.5\gamma BN\gamma - \gamma D$$

$$q_n = cN_c + \gamma D(N_q - 1) + 0.5\gamma BN\gamma$$

Safe bearing capacity,

$$q_s = [cN_c + \gamma D(N_q - 1) + 0.5\gamma BN\gamma] / F + \gamma D$$

Here, F = Factor of safety (usually 3) c

= cohesion

γ = unit weight of soil D =

Depth of foundation

q = Surcharge at the ground level B

= Width of foundation

N_c, N_q, N_γ = Bearing Capacity factor

Effect of shape of Foundation

The shape of footing influences the bearing capacity. Terzaghi and other contributors have suggested the correction to the bearing capacity equation for shapes other than strip footing based on their experimental findings. The following are the corrections for circular, square and rectangular footings.

Circular footing

$$q_f = 1.3cN_c + \gamma D N_q + 0.3\gamma BN\gamma$$

Square footing

$$q_f = 1.3cN_c + \gamma D N_q + 0.4\gamma BN\gamma$$

Rectangular footing

$$q_f = \left(1 + 0.3 \frac{B}{L}\right) c N_c + \gamma D N_q + \left(1 - 0.2 \frac{B}{L}\right) 0.5\gamma BN$$

Summary of Shape factors

Table gives the summary of shape factors suggested for strip, square, circular and rectangular footings. B and L represent the width and length respectively of rectangular footing such that $B < L$.

Shape factors for different shapes of footing

Shape	sc	sq	s
Strip	1	1	1
Square	1.3	1	0.8
Round	1.3	1	0.6
Rectangle	$(1 + 0.3B/L)$	1	$(1 - 0.2B/L)$

Local shear failure

The equation for bearing capacity explained above is applicable for soil experiencing general shear failure. If a soil is relatively loose and soft, it fails in local shear failure. Such a failure is accounted in bearing capacity equation by reducing the magnitudes of strength parameters c and Φ as follows.

$$\tan \Phi_l = 2/3 \tan \Phi$$

$$c_l = 2/3 c$$

Table summarizes the bearing capacity factors to be used under different situations. If Φ is less than 36° and more than 28° , it is not sure whether the failure is of general or local shear type. In such situations, linear interpolation can be made and the region is called mixed zone.

Bearing capacity factors in zones of local, mixed and general shear conditions.

Local Shear Failure	Mixed Zone	General Shear Failure
$\Phi < 28^\circ$	$28^\circ < \Phi < 36^\circ$	$\Phi > 36^\circ$
N_c, N_q, N_γ	N_c^m, N_q^m, N_γ^m	N_c, N_q, N_γ

Effect of Water Table fluctuation

The basic theory of bearing capacity is derived by assuming the water table to be at great depth below and not interfering with the foundation. However, the presence of water table at foundation depth affects the strength of soil. Further, the unit weight of soil to be considered in the presence of water table is submerged density and not dry density. Hence, the reduction coefficients RW1 and RW2 are used in second and third terms of bearing capacity equation to consider the effects of water table.

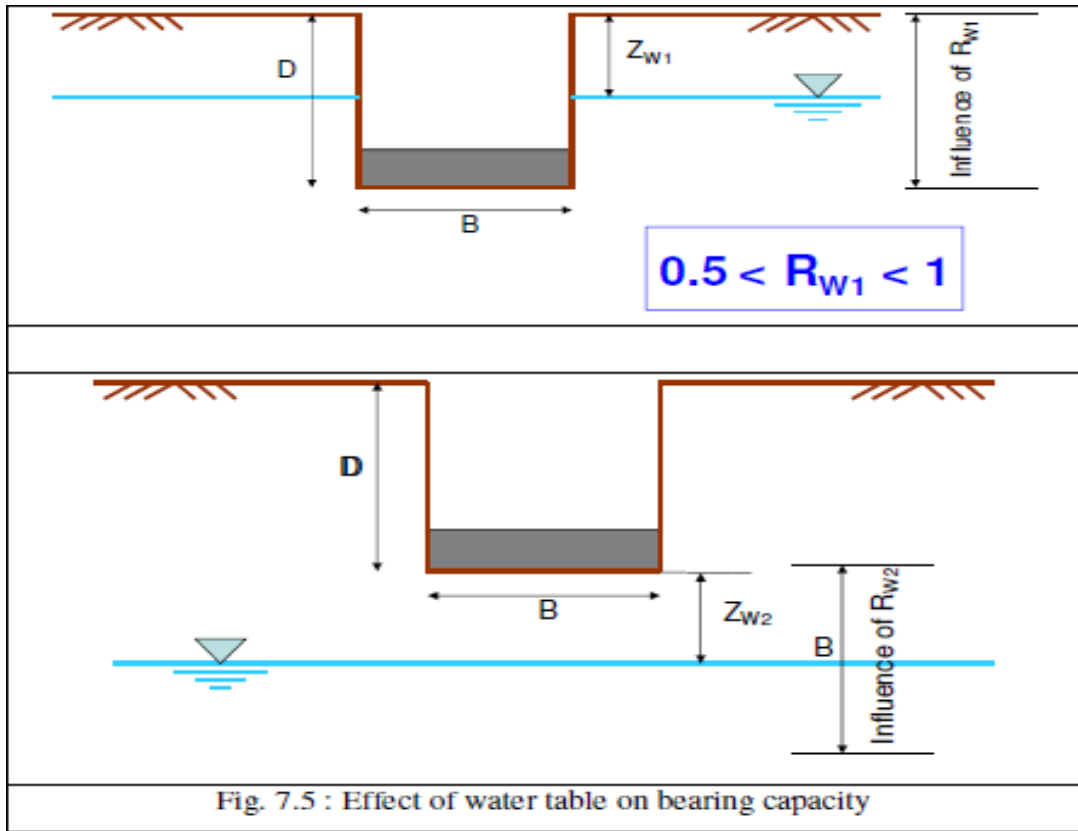

Ultimate bearing capacity with the effect of water table is given by,

$$q_f = cN_c + gDN_q R_{w1} + 0.5gBN_g R_{w2}$$

$$R_{w1} = \frac{1 + Z_{w1}}{D}$$

where Z_{w1} is the depth of water table from ground level.

1. $0.5 < R_{w1} < 1$

2. When water table is at the ground level ($Z_{w1} = 0$), $R_{w1} = 0.5$

3. When water table is at the base of foundation ($Z_{w1} = D$), $R_{w1} = 1$

4. At any other intermediate level, R_{w1} lies between 0.5 and 1

$$R_{w2} = \frac{1 + Z_{w2}}{D}$$

where Z_{w2} is the depth of water table from foundation level.

1. $0.5 < R_{w2} < 1$
2. When water table is at the base of foundation ($Z_{w2} = 0$), $R_{w2} = 0.5$
3. When water table is at a depth B and beyond from the base of foundation ($Z_{w2} \geq B$), $R_{w2} = 1$
4. At any other intermediate level, R_{w2} lies between 0.5 and 1

Effect of eccentric foundation base

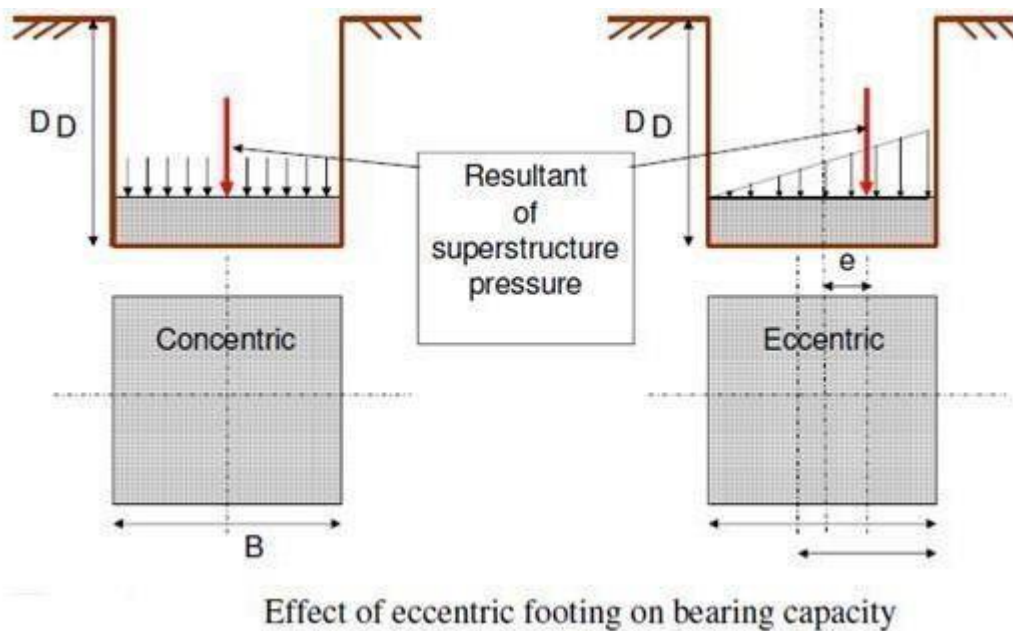

The bearing capacity equation is developed with the idealization that the load on the foundation is concentric. However, the forces on the foundation may be eccentric or foundation may be subjected to additional moment. In such situations, the width of foundation B shall be considered as follows.

$$B^1 = B - 2e$$

If the loads are eccentric in both the directions, then

$$B^1 = B - 2e_B \quad \& \quad L^1 = L - 2e_L$$

Further, area of foundation to be considered for safe load carried by foundation is not the actual area, but the effective area as follows.

$$A^1 = B^1 \times L^1$$

In the calculation of bearing capacity, width to be considered is B^1 where $B^1 < L^1$. Hence the effect of provision of eccentric footing is to reduce the bearing capacity and load carrying capacity of footing.

Factor of Safety

It is the factor of ignorance about the soil under consideration. It depends on many factors such as,

1. Type of soil
2. Method of exploration
3. Level of Uncertainty in Soil Strength
4. Importance of structure and consequences of failure
5. Likelihood of design load occurrence, etc.

Assume a factor of safety $F = 3$, unless otherwise specified for bearing capacity problems. Table 7.5 provides the details of factors of safety to be used under different circumstances.

Typical factors of safety for bearing capacity calculation in different situations

Category	Typical Structures	Characteristics of the Category	Design Factor of Safety	
			Thorough and Complete Soil Exploration	Limited Soil Exploration
A	Railway bridges, warehouses, blast furnaces, hydraulic, retaining walls, silos	Maximum design load likely to occur often; consequences of failure disastrous	3.0	4.0
B	Highway bridges, light industrial and public buildings	Maximum design loads may occur occasionally, consequences of failure serious	2.5	3.5
C	Apartment and office buildings	Maximum design load unlikely to occur	2.0	3.0

Density of soil: In geotechnical engineering, one deals with several densities such as dry density, bulk density, saturated density and submerged density. There will always be a doubt in the students mind as to which density to use in a particular case. In case of Bearing capacity problems, the following methodology may be adopted.

1. Always use dry density as it does not change with season and it is always smaller than bulk or saturated density.
2. If only one density is specified in the problem, assume it as dry density and use.
3. If the water table correction is to be applied, use saturated density in stead of dry density. On portions above the water table, use drydensity.

4. If water table is some where in between, use equivalent density as follows. In the case shown in Fig. 7a, e_q should be used for the second term and s_{at} for the third term. In the case shown in Fig. 7b, d should be used for second term and e_q for the third term.

$$g = (g_1 D_1 + g_2 D_2) / (D_1 + D_2)$$

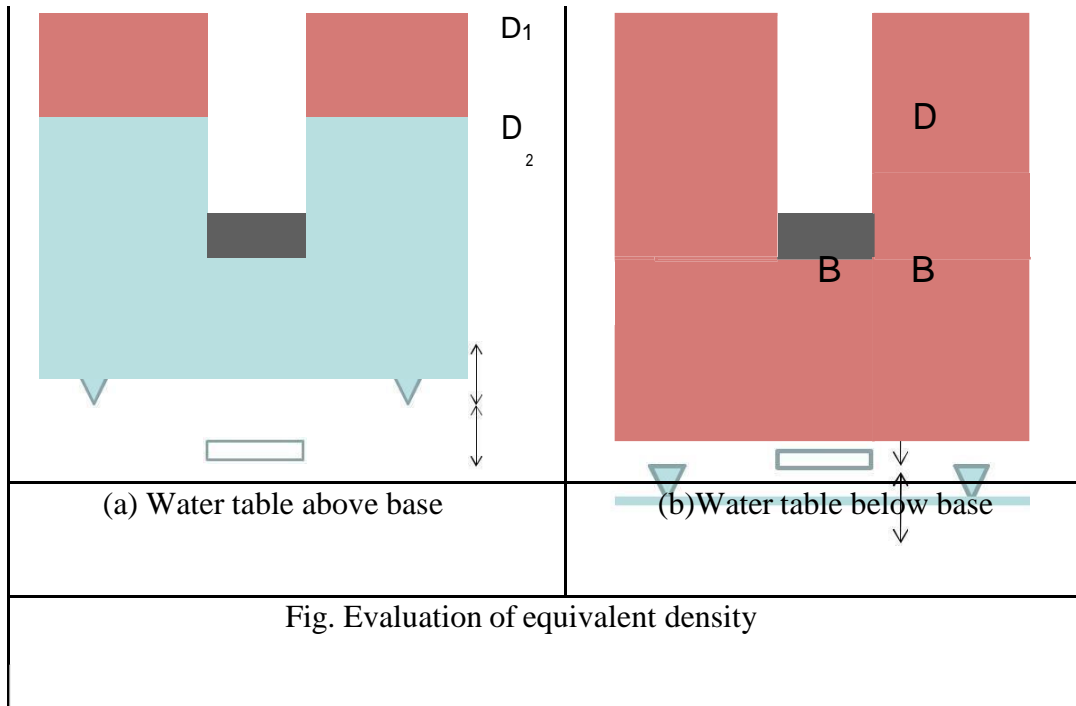

Factors influencing Bearing Capacity

Bearing capacity of soil depends on many factors. The following are some important ones.

1. Type of soil
2. Unit weight of soil
3. Surcharge load
4. Depth of foundation
5. Mode of failure
6. Size of footing
7. Shape of footing
8. Depth of water table
9. Eccentricity in footing load

10. Inclination of footing load
11. Inclination of ground
12. Inclination of base of foundation

Brinch Hansen's Bearing Capacity equation

As mentioned in previous section, bearing capacity depends on many factors and Terzaghi's bearing capacity equation does not take in to consideration all the factors. Brinch Hansen and several other researchers have provided a comprehensive equation for the determination bearing capacity called Generalized Bearing Capacity equation considering the almost all the factors mentioned above. The equation for ultimate bearing capacity is as follows from the comprehensive theory.

$$q_u = cN_c s_c d_c i_c + qN_q s_q d_q i_q + 0.5\gamma B N_\gamma s_\gamma d_\gamma i_\gamma$$

Here, the bearing capacity factors are given by the following expressions which depend on .

$$N_c = (N_q - 1) \cot f$$

$$N_q = (e^{p \tan f}) \tan^2(45 + f/2)$$

$$N_\gamma = 1.5(N_q - 1) \tan f$$

Equations are available for shape factors (s_c, s_q, s_γ), depth factors (d_c, d_q, d_γ) and load inclination factors (i_c, i_q, i_γ). The effects of these factors are to reduce the bearing capacity.

Determination of Bearing Capacity from field tests

Field Tests are performed in the field. You have understood the advantages of field tests over laboratory tests for obtaining the desired property of soil. The biggest advantages are that there is no need to extract soil sample and the conditions during testing are identical to the actual situation.

Plate Load Test

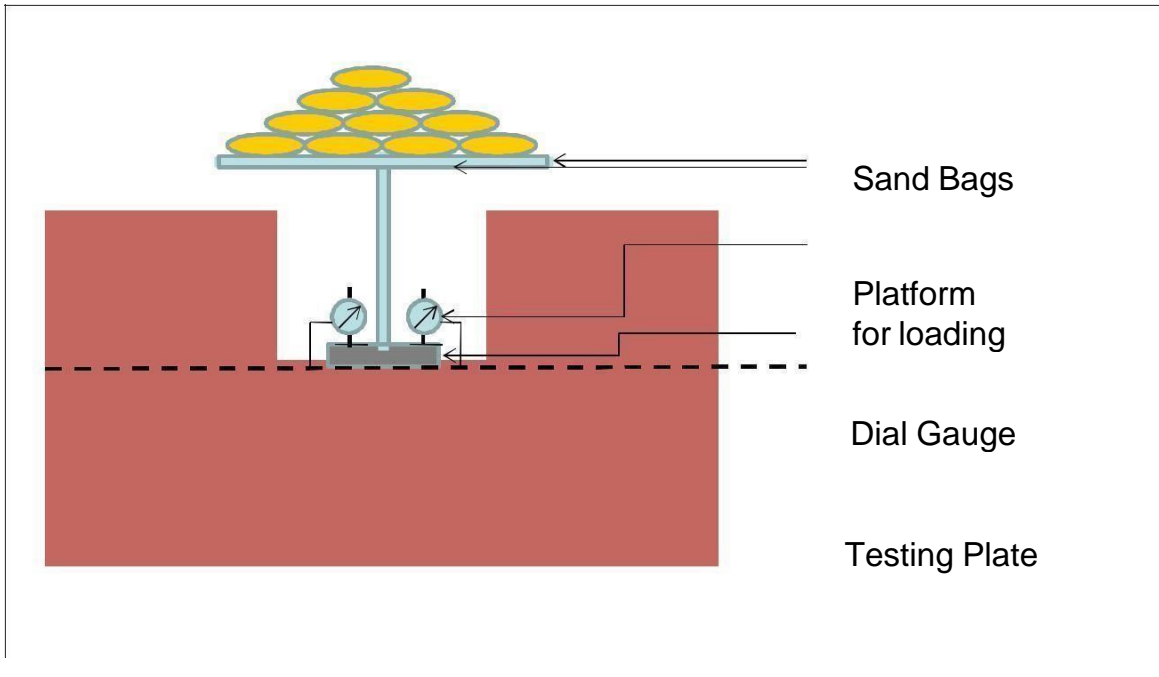

Major advantages of field tests are

- Sampling not required
- Soil disturbance minimum

Major disadvantages of field tests are

- Labourious
- Time consuming
- Heavy equipment to be carried to field
- Short duration behavior

1. It is a field test for the determination of bearing capacity and settlement characteristics of ground in field at the foundation level.
2. The test involves preparing a test pit up to the desired foundation level.
3. A rigid steel plate, round or square in shape, 300 mm to 750 mm in size, 25 mm thick acts as model footing.
4. Dial gauges, at least 2, of required accuracy (0.002 mm) are placed on plate on plate at corners to measure the vertical deflection.

6. Loading is provided either as gravity loading or as reaction loading. For smaller loads gravity loading is acceptable where sand bags apply the load. In reaction loading, a reaction truss or beam is anchored to the ground. A hydraulic jack applies the reaction load.
7. At every applied load, the plate settles gradually. The dial gauge readings are recorded after the settlement reduces to least count of gauge (0.002 mm) & average settlement of 2 or more gauges is recorded.
8. Load Vs settlement graph is plotted as shown. Load (P) is plotted on the horizontal scale and settlement (s) is plotted on the vertical scale.
9. Red curve indicates the general shear failure & the blue one indicates the local or punching shear failure.
10. The maximum load at which the shear failure occurs gives the ultimate bearing capacity of soil.

Reference can be made to IS 1888 - 1982.

The advantages of Plate Load Test are

1. It provides the allowable bearing pressure at the location considering both shear failure and settlement.
2. Being a field test, there is no requirement of extracting soil samples.
3. The loading techniques and other arrangements for field testing are identical to the actual conditions in the field.
4. It is a fast method of estimating ABP and P – behaviour of ground.

The disadvantages of Plate Load Test are

1. The test results reflect the behaviour of soil below the plate (for a distance of $\sim 2B_p$), not that of actual footing which is generally very large.
2. It is essentially a short duration test. Hence, it does not reflect the long term consolidation settlement of clayey soil.
3. Size effect is pronounced in granular soil. Correction for size effect is essential in such soils.
4. It is a cumbersome procedure to carry equipment, apply huge load and carry out testing for several days in the tough field environment.

Standard Penetration Test

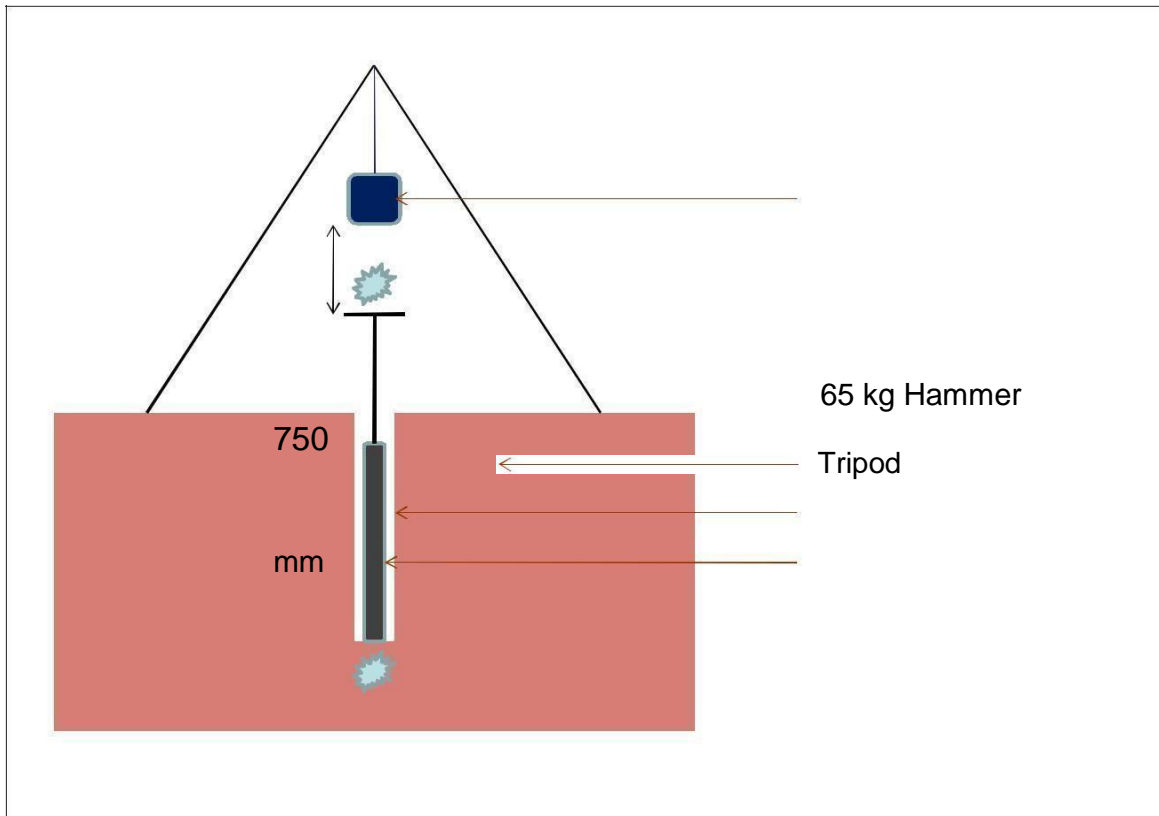

Bore Hole, Split Spoon Sampler

Fig. : Typical set up for Standard Penetration test assembly

1. Reference can be made to IS 2131 – 1981 for details on Standard Penetration Test.
2. It is a field test to estimate the penetration resistance of soil.
3. It consists of a split spoon sampler 50.8 mm OD, 35 mm ID, min 600 mm long and 63.5 kg hammer freely dropped from a height of 750 mm.
4. Test is performed on a clean hole 50 mm to 150 mm in diameter.
5. Split spoon sampler is placed vertically in the hole, allowed to freely settle under its own weight or with blows for first 150 mm which is called seating drive.
6. The number of blows required for the next 300 mm penetration into the ground is the standard penetration number N

7. Apply the desired corrections (such as corrections for overburden pressure, saturated fine silt and energy)
8. N is correlated with most properties of soil such as friction angle, undrained cohesion, density etc.

Advantages of Standard Penetration Test are

1. Relatively quick & simple to perform
2. Equipment & expertise for test is widely available
3. Provides representative soil sample
4. Provides useful index for relative strength & compressibility of soil
5. Able to penetrate dense & stiff layers
6. Results reflect soil density, fabric, stress strain behavior
7. Numerous case histories available

Disadvantages of Standard Penetration Test are

1. Requires the preparation of bore hole.
2. Dynamic effort is related to mostly static performance
3. SPT is abused, standards regarding energy are not uniform
4. If hard stone is encountered, difficult to obtain reliable result.
5. Test procedure is tedious and requires heavy equipment.
6. Not possible to obtain properties continuously with depth.

Cone Penetration Test

1. Reference can be made to IS 4968 (P3) – 1987 for details on Standard Penetration Test.
2. Cone Penetration Test can either be Static Cone Penetration Test or Dynamic Cone Penetration Test.

3. Continuous record of penetration resistance with depth is achieved.
4. Consists of a cone 36 mm dia (1000 mm^2) and 60° vertex angle.
5. Cone is carried at the lower end of steel rod that passes through steel tube of 36 mm dia.
6. Either the cone, or the tube or both can be forced in to the soil by jacks.
7. Cone is pushed 80 mm in to the ground and resistance is recorded, steel tube is pushed up to the cone and resistance is recorded. Further, both cone and tube are penetrated 200 mm and resistance is recorded. Total resistance (q_c) gives the CPT value expressed in kPa.
8. Cone resistance represents bearing resistance at the base and tube resistance gives the skin frictional resistance. Total resistance can be correlated with strength properties, density and deformation characteristics of soil.

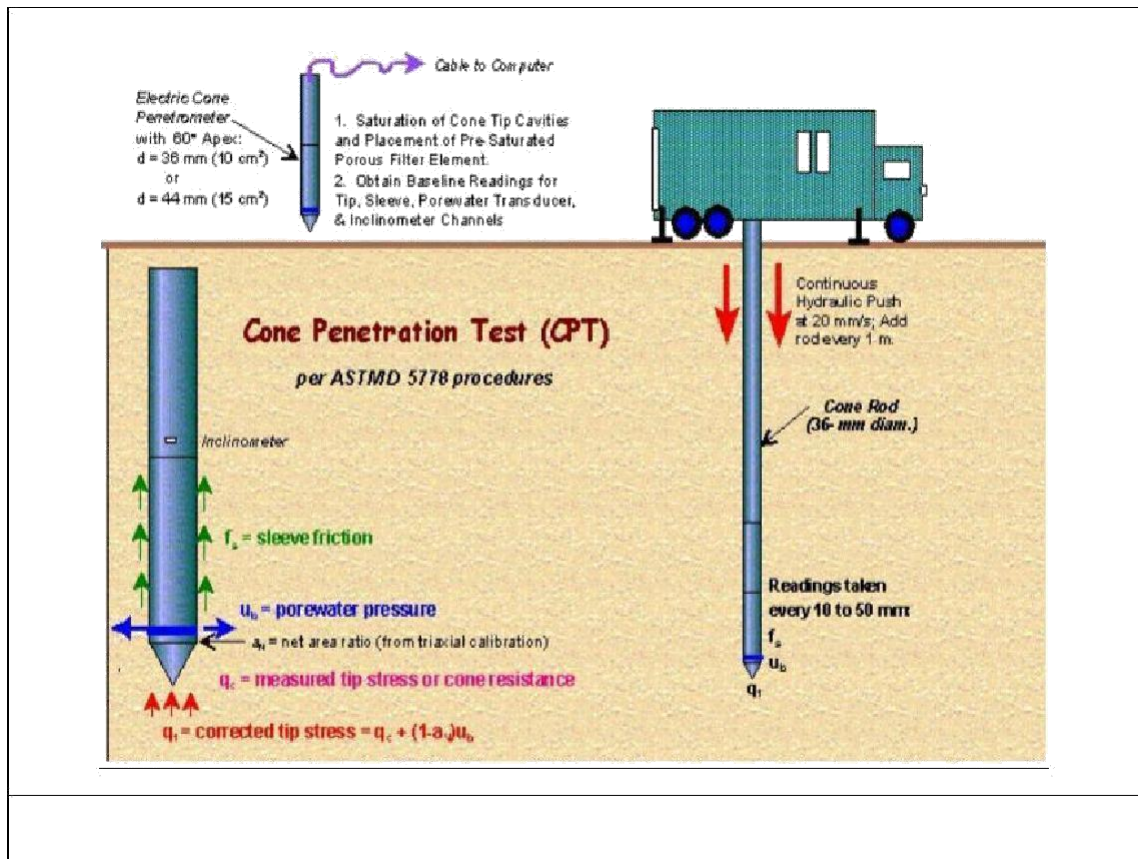

9. Correction for overburden pressure is applied. Approximately, $N = 10q_c$ (kPa)

Advantages of SCPT are

1. Continuous resistance with depth is recorded.
2. Static resistance is more appropriate to determine static properties of soil.
3. Can be correlated with most properties of soil.

Disadvantages of SCPT are

1. Not very popular in India.
2. If a small rock piece is encountered, resistance shown is erratic & incorrect.
3. Involves handling heavy equipment.

Presumptive Safe Bearing Capacity

It is the bearing capacity that can be presumed in the absence of data based on visual identification at the site. National Building Code of India (1983) lists the values of presumptive SBC in kPa for different soils as presented below.

A : Rocks

Sl No	Description	SBC (kPa)
1	Rocks (hard) without laminations and defects. For e.g. granite, trap & diorite	3240
2	Laminated Rocks. For e.g. Sand stone and Lime stone in sound condition	1620
3	Residual deposits of shattered and broken bed rocks and hard shale cemented material	880
4	Soft Rock	440

B : Cohesionless Soils

Sl No	Description	SBC (kPa)
1	Gravel, sand and gravel, compact and offering resistance to penetration when excavated by tools	440
2	Coarse sand, compact and dry	440
3	Medium sand, compact and dry	245
4	Fine sand, silt (dry lumps easily pulverized by fingers)	150
5	Loose gravel or sand gravel mixture, Loose coarse to medium sand, dry	245
6	Fine sand, loose and dry	100

C : Cohesive Soils

Sl No	Description	SBC (kPa)
1	Soft shale, hard or stiff clay in deep bed, dry	440
2	Medium clay readily indented with a thumb nail	245
3	Moist clay and sand clay mixture which can be indented with strong thumb pressure	150
4	Soft clay indented with moderate thumb pressure	100
5	Very soft clay which can be penetrated several centimeters with the thumb	50
6	Black cotton soil or other shrinkable or expansive clay in dry condition (50 % saturation)	130 - 160

Note :

1. Use γ for all cases without water. Use γ_{sat} for calculations with water. If simply density is mentioned use accordingly.
2. Fill all the available data with proper units.
3. Write down the required formula
4. If the given soil is sand, $c = 0$

Problems & Solutions

1. A square footing is to be constructed on a deep deposit of sand at a depth of 0.9 m to carry a design load of 300 kN with a factor of safety of 2.5. The ground water table may rise to the ground level during rainy season. Design the plan dimension of footing
given $\gamma_{sat} = 20.8 \text{ kN/m}^3$, $N_c = 25$, $N_q = 34$ and $N_{\gamma} = 32$. (Feb 2002)

Data

$$C = 0$$

$$F = 2.5$$

$$D = 0.9 \text{ m}$$

$$RW_1 = RW_2 = 0.5$$

$$\gamma_{sat} = 20.8 \text{ kN/m}^3$$

$$= 20.8 \text{ kN/m}^3$$

$$N_c = 25$$

$$N_q = 34$$

$$N_{\gamma} = 32$$

$$q_s = P/A = [1.3cN_c + \gamma D(N_q - 1)R_{W1} + 0.4\gamma B N_{\gamma} R_{W2}]$$

$$B = 1.21 \text{ m}$$

2. What will be the net ultimate bearing capacity of sand having $\phi = 36^\circ$ and $\gamma_d = 19 \text{ kN/m}^3$ for
 (i) 1.5 m strip foundation and (ii) 1.5 m X 1.5 m square footing. The footings are placed at a depth of 1.5 m below ground level. Assume $F = 2.5$. Use Terzaghi's equations. (Aug 2003)

	N_c	N_q	N
35°	57.8	41.4	42.4
40°	95.7	81.3	100.4

By linear interpolation $N_c = 65.38$, $N_q = 49.38$, $N_\gamma = 54$ at $\phi = 36^\circ$

Data

$B = 1.5 \text{ m}$

$D = 1.5 \text{ m}$

$\gamma_d = 19 \text{ kN/m}^3$

Strip Footing

$$q_n = cN_c + \gamma D(N_q - 1) + 0.5\gamma B N_\gamma$$

$q_n = 2148.33 \text{ kPa}$

Square Footing

$$q_n = 1.3cN_c + \gamma D(N_q - 1) + 0.4\gamma B N_\gamma$$

$q_n = 1994.43 \text{ kPa}$

3. A square footing 2.5 m X 2.5 m is built on a homogeneous bed of sand of density 19 kN/m³ having an angle of shearing resistance of 36°. The depth of foundation is 1.5 m below the ground surface. Calculate the safe load that can be applied on the footing with a factor of safety of 3. Take bearing capacity factors as $N_c = 27$, $N_q = 30$, $N = 35$. (Feb 2004)

Data

$$C = 0 \quad F = 3$$

$$B = 2.5$$

$$D = 1.5 \text{ m}$$

$$\gamma_d = 19 \text{ kN/m}^3$$

$$N_c = 27 \quad N_q = 30 \quad N = 35$$

$$q_s = P/A = [1.3cN_c + \gamma D(N_q - 1)R_{w1} + 0.4\gamma B N \gamma R_{w2}]$$

$$\text{Safe load, } P = q_s * B * B = 3285.4 \text{ KN}$$

4. A strip footing 2 m wide carries a load intensity of 400 kPa at a depth of 1.2

m in sand. The saturated unit weight of sand is 19.5 kN/m³ and unit weight above water table

is 16.8 kN/m³. If $c = 0$ and $\phi = 35^\circ$, determine the factor of safety with respect to shear failure

for the following locations of water table.

Water table is 4 m below Ground Level

Water table is 1.2 m below Ground Level

Water table is 2.5 m below Ground Level

Water table is at Ground Level.

Using Terzaghi's equation, take $N_q = 41.4$ and $N_\gamma = 42.4$. (Feb 2005)

Data

$$C = 0 \text{ and } \phi = 35^\circ$$

$$B = 2 \text{ m}$$

$$D = 1.2 \text{ m}$$

$$b = 19.5 \text{ kN/m}^3 \text{ (bottom)} \quad \gamma_{\text{sat}} = 16.8 \text{ kN/m}^3 \text{ (top)}$$

$$N_c = 0$$

$$N_q = 41.4$$

$$N_\gamma = 42.4$$

Safe load intensity = 400 kPa

$$q_s = 400 = \left[c N_c + \gamma D (N_q - 1) R_{w1} + 0.5 \gamma B N_\gamma R_{w2} \right] \frac{1}{F} + D$$

a. Water table is 4 m below Ground Level

$$R_{w1} = R_{w2} = 1$$

$$\gamma_{\text{sat}} = 16.8 \text{ kN/m}^3$$

$$F = 4.02$$

b. Water table is 1.2 m below Ground Level $R_{w1} = 1$, $R_{w2} = 0.5$

$$400 = \left[16.8 \times 1.2 \times 40.4 \times 1 + 0.5 \times 19.5 \times 2 \times 42.4 \times 0.5 \right] \frac{1}{F} + 16.8 \times 1.2$$

$$F = 3.227$$

c. Water table is 2.5 m below Ground Level $R_{w2} = 0.5(1 + 1.3/2) = 0.825$

$$\gamma_{\text{eff}} = 16.8 \times 1.3 + 19.5 \times 0.7 = 17.745 \text{ kN/m}^3$$

2

$$400 = \left[16.8 \times 1.2 \times 40.4 \times 1 + 0.5 \times 17.745 \times 2 \times 42.4 \times 0.825 \right] \frac{1}{F} + 16.8 \times 1.2$$

$$F = 3.779$$

d. Water table is at Ground Level $R_{w1} = R_{w2} = 0.5$

$$\gamma_{\text{sat}} = 19.5 \text{ kN/m}^3$$

$$400 = \left[19.5 \times 1.2 \times 40.4 \times 0.5 + 0.5 \times 19.5 \times 2 \times 42.4 \times 0.5 \right] \frac{1}{F} + 19.5 \times 1.2$$

$$F = 2.353$$

5. A square footing located at a depth of 1.3 m below ground has to carry a safe load of 800 kN. Find the size of footing if the desired factor of safety is 3.

Use Terzaghi's analysis for general shear failure. Take $c = 8$ kPa, $N_c = 37.2$, $N_q = 22.5$, $N = 19.7$. (Aug 2005)

$$\gamma_d = 18 \text{ kN/m}^3 \text{ (Assumed)}$$

$$c = 8 \text{ kPa } F = 3$$

$$D = 1.3 \text{ m } N_c = 37.2$$

$$N_q = 22.5$$

$$N = 19.7$$

$$P = 800 \text{ kN } R_{W1} = R_{W2} = 1$$

$$q_s = P/A = P/B^2 = [1.3cN_c + \gamma D(N_q - 1)R_{W1} + 0.4\gamma BN_g R_{W2}] \frac{1}{F + \gamma D}$$

$$47.28B^3 + 320.06B^2 - 800 = 0$$

$$B = 1.436 \text{ m}$$

6. A square footing 2.8 m X 2.8 m is built on a homogeneous bed of sand of density 18 kN/m

o

and $\gamma = 18$. If the depth of foundation is 1.8 m, determine the safe load that can be applied on

the footing. Take $F = 2.5$, $N_c = 27$, $N_q = 36$, $N_\gamma = 35$. (Feb 2007) Data

$$\gamma = 18 \text{ kN/m}^3 \quad c = 0 \text{ (sand)} \quad F = 2.5$$

$$B = 2.8 \text{ m } D = 1.8 \text{ m } N_c = 27$$

$$N_q = 36$$

$$N_\gamma = 35 \quad P = ?$$

$$R_{W1} = R_{W2} = 1$$

$$q_s = P/A = P/B^2 = [1.3cN_c + \gamma D(N_q - 1)R_{W1} + 0.4\gamma BN_g R_{W2}] \frac{1}{F + \gamma D}$$

$$P = q_s \cdot B \cdot B = 6023 \text{ kN}$$

7. A strip footing 1 m wide and a square footing 1 m side are placed at a depth of 1 m below

o

the ground surface. The foundation soil has cohesion of 10 kPa, angle of friction of 26° and unit weight of 18 kN/m^3 . Taking bearing capacity factor from the following table, calculate the safe bearing capacity using Terzaghi's theory. Use factor of safety of 3. (July 2008)

	N_c	N_q	N
15°	12.9	4.4	2.5
20°	17.7	7.0	5.0
25°	25.1	12.7	9.7

1. A strip footing 1 m wide and a square footing 1 m side are placed at a depth of 1 m below the ground surface. The foundation soil has cohesion of 10 kPa, angle of friction of 26° and unit weight of 18 kN/m^3 . Taking bearing capacity factor from the following table, calculate the safe bearing capacity using Terzaghi's theory. Use factor of safety of 3. (July 2008)

	N_c	N_q	N
15°	12.9	4.4	2.5
20°	17.7	7.0	5.0
25°	25.1	12.7	9.7

As $= 28^\circ$, the ground experiences local shear failure $C' = (2/3) \times 10 = 6.67 \text{ kPa}$

$$\tan \phi' = (2/3) \times \tan 28^\circ = 18.01^\circ$$

By linear interpolation, $N_c' = 15.79$, $N_q' = 5.97$, $N_\gamma' = 4.01$ $B = 1 \text{ m}$

$$D = 1 \text{ m}$$

$$\gamma_{sat} = 18 \text{ kN/m}^3$$

Strip footing

$$q_s = cN_c + \gamma D(N_q - 1) + 0.5\gamma B N_\gamma = 94.96 \text{ kPa}$$
 Square footing

$$q_s = 1.3cN_c + \gamma D(N_q - 1) + 0.4\gamma B N_\gamma = 103.08 \text{ kPa}$$

8. A square footing placed at a depth of 1 m is required to carry a load of 1000kN. Find the

required size of footing given the following data. $C = 10 \text{ kPa}$, $\phi = 38^\circ$, $\gamma = 19 \text{ kN/m}^3$, $N_c =$

61.35 , $N_q = 48.93$, $N_\gamma = 74.03$ and $F = 3$. Assume water table is at the base of footing. (July 2007)

Data

$$C = 10 \text{ kPa} = 38^\circ \phi = ?$$

$$D = 1 \text{ m} = 19 \text{ kN/m}^3$$

$$N_c = 61.35$$

$$N_q = 48.93$$

$$N_\gamma = 74.03$$

$$F = 3$$

$$R_{W1} = 1$$

$$R_{W2} = 0.5$$

$$q_s = A = B^2 = \left[1.3cN_c + \gamma D(N_q - 1)R_{W1} + 0.4\gamma BN_\gamma R_{W2} \right] / F + gD$$

$$B^3 + 6.14B^2 - 3.56 = 0$$

$$B = 0.72 \text{ m}$$

SETTLEMENT.

The vertical downward movement of the base of a structure is called settlement and its effect upon the structure depends on its magnitude, its uniformity, the length of the time over which it takes place, and the nature of the structure itself. Settlement has got several implications on a foundation.

The implications include:

Appearance of structures

Utility of structures

Damage to the structures

Appearance of structures Settlement affects the appearance of structures. If a structure settles excessively, its aesthetic is impaired. It causes doors and windows to distort, walls and plasters to crack and the structure to tilt.

Utility of Structures – Settlement interfere the utility of structures in many ways. If settlement is excessive overhead cranes do not operate correctly, machinery may go out of plumb and tracking units such as radar become inaccurate.

Damage to the Structure – If the settlement is severe, it may lead to the complete collapse of the structure even though the factor of safety against shear failure is high.

All foundations settle to some extent as the earth materials around and beneath them adjust to loads of the building. Foundations on bedrock settle a negligible amount. Foundations in other types of soil may settle much more. Foundations in clay settle more. Where foundation settlement occurs at roughly the same rate throughout all portions of a building, it is termed **uniform settlement**. Settlement that occurs at differing rates between different portions of a building is termed **differential settlement**.

When all parts of a building rest on the same kind of soil, and the loads on the building and the design of its structural system are uniform throughout, differential settlement is normally not a concern. However where soils, loads, or structural systems differ between parts of a building, different parts of the building structure may settle by substantially different amounts, the frame of the building may become distorted, floors may slope, walls and glass may crack, and doors and windows may not work properly. Figure 1 shows the details of settlement.

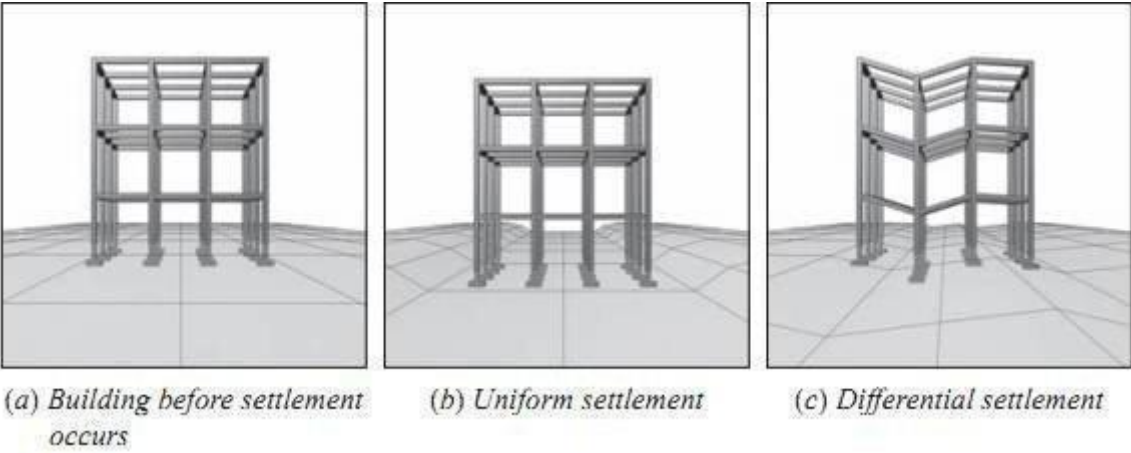

Fig. 1: Types of settlement of foundation of building

Settlement deals with the sinking of structure due to compression of soil. **As per IS code, the following types of settlements are reported:**

Total settlement: - it is combination of initial and consolidation settlement Elastic settlement/

initial settlement: - initial/elastic settlement is the settlement caused due to elastic properties of the soil due to applied load.

Consolidation settlement - Primary consolidation: - is the consolidation occurs due to the expulsion of air from the voids.

Secondary/creep:- is the consolidation due to expulsion of water from the voids.

Differential settlement/ angular distortion: - it is the difference in settlement between two points below the footing.

Time dependent settlement: -for sands, settlement is called immediate settlement as it is the major settlement, there being no or very less consolidation settlement. For clays, we talk about initial or elastic settlements and not immediate settlements.

Foundation settlement is the shifting of the foundation (and the structure built upon it) into the soil. This can cause damage to the structure. Whether the soil is moist or dry is central to predicting the amount of settlement to expect in a given foundation. Areas with moist soils will have more foundation settlement than dry areas. The idea is that as water is squeezed out from the soil, the structure will shift according to the empty spaces the water left. The more water, the more shift.

Immediate Settlement

Immediate settlement concerns the initial pressure on the soil under and surrounding the foundation. It is "immediate" because it occurs during and right after construction. It has nothing to do with water displacement, but is merely caused by the weight of the structure. In terms of building foundations, immediate settlement is relatively easy to predict and measure. In many cases, given the nature of the soil, foundations are constructed with the ability to withstand a certain amount of shift without damage. Damage usually occurs only in the long term, as the shift slowly continues over time.

Consolidation

Consolidation settlement is distinguished from immediate settlement both by the duration of the settlement and by displacement of water. Consolidation is the more worrisome form of settlement because it is difficult to predict over months or years. Consolidation settlement is the settling of a foundation, over time, due to pressure exerted by the structure and squeezes out the water content of the soil, thus compressing it. Expulsion of moisture from the soil usually is a long-term process.

Primary and Secondary Consolidation

Consolidation settlement has two components, primary and secondary. The former deals explicitly with the settlement caused by soil moisture displacement, and the latter deals with the elastic settlement after all movable water has been squeezed out of the soil.

Primary consolidation is the most significant and potentially harmful of the two. Primary consolidation takes quite a bit of time, from weeks to years. Secondary consolidation is the quicker result of primary consolidation. Once primary has been completed, and all movable water has been moved, secondary kicks in. Secondary consolidation occurs immediately after primary, and takes far less time to complete. After secondary consolidation is complete, the structure remains in its permanent position. As a result, many builders advise a resident in new homes to avoid repairing any settlement damage until secondary consolidation is complete, which is normally after two years at most.

Causes of foundation Settlement

The causes of **foundation settlement** are rarely due to the design (or under-design) of the structure itself. More commonly, damage is caused as changes occur within the foundation soils that surround and support the structure

Foundation settlement may be caused by some or a combination of the following reasons

Elastic compression of the foundation and the underlying soil.

Inelastic (or plastic) compression of the underlying soils, which is much larger than the elastic compression. The inelastic compression can be predicted by the theory of consolidation.

Ground water lowering. Repeated lowering and rising of water level in loose granular soil tends to compact the soil and cause settlement of the ground surface. Lowering of water level in fine grained soils cause consolidation settlement. The major settlements in the city of Mexico has been due to ground water lowering, and due to this, the city has been called as the 'sinking city of Mexico'.

Vibrations due to pile driving, blasting and oscillating machineries may cause settlement in deposits of granular soils.

Seasonal swelling and shrinkage of expansive clays.

Ground movement on earth slopes, such as surface erosion, slow creep or landslide.

Other causes such as adjacent excavation, mining subsidence, underground erosion, etc.



(b)

Cracks in your home's walls and sticking doors and windows are two of the symptoms of foundation settlement.

Bricks crack when foundation walls sink

[Check out these common causes that call for professional evaluation and foundation repairs.](#)

Do you have foundation cracks, wall cracks, sticking doors and windows and sloping floors? Foundation cracks due to differential foundation settlement can be caused by several conditions. **Frost heave**

Building codes that require at least 30 inches for a building's footing depth were established to resist frost heave from ice expansion in the ground during the winter months. The top layer of soil has gone through these types of changes over the decades and is typically not very compacted.

Soil type

Some soils, like those we have here in the Greater Cincinnati area, are classified as expansive clay. This type of soil changes volume when its moisture content changes. The soil shrinks in the dry summer and fall, when the rain quits falling as seen by cracks in ground. When the moisture returns to the soil during the winter and spring due to higher quantities of rain and snow, the soil swells back to its previous volume. This type of differential movement can be seen in houses that have cyclical cracks which open and close, doors rubbing the frames part of the year during the various seasons. Watering along the exterior house foundation may help control this movement, but should be started very early in the year.

Varying foundation depth

Foundations that are supported at different soil depths are likely to settle differentially. This condition is typical when a shallow foundation is placed near a deeper basement foundation or on sloping lots.

Water leaks

In older homes, underground waste piping and/or underground downspout piping can crack or break. When the piping fails; water leaks along the footing, softening the soil, causing the foundation to settle differentially. After a building has been constructed, some settlement is quite normal. Differential settlement, however, is when a building's piers or foundation settles unequally. Differential settlement can result in damage to the structure, and is therefore, of concern.

Common causes of foundation settlement

Weak Bearing Soils

Some soils are simply not capable of supporting the weight or bearing pressure exerted by a building's foundation. As a result, the footings press or sink into the soft soils, similar in theory to how a person standing in the mud sinks into soft, wet clay.

In such cases, footings may be designed to spread the load over the weak soils, thereby reducing potential foundation settlement. However, the majority of **settlement problems** caused by weak bearing soils occur in residential construction, where the footings are designed based upon general guidelines and not site-specific soil information.

Poor Compaction

Placement of fill soils is common practice in the development of both commercial and residential subdivisions. In general, before a foundation can be constructed on a plot, hilltops are cut down and valleys are filled in order to create buildable lots. Properly placed and compacted fill soils can provide adequate support for foundations, and are sometimes brought in from off-site locations. When the soilfills are not adequately compacted, they can compress under a foundation load resulting in settlement of the structure.



Changes in Moisture Content

Extreme changes in moisture content within foundation soils can result in **damaging settlement**. Excess moisture can saturate foundation soils, which often leads to softening or weakening of clays and silts. The reduced ability of the soil to support the load results in foundation settlement. Increased moisture within foundation soils is often a consequence of poor surface drainage around the structure, leaks in water lines or plumbing, or a raised groundwater table. Soils with high clay contents also have a tendency to shrink with loss of moisture. As clay soils dry out, they shrink or contract, resulting in a general decrease in soil volume.

Therefore, **settlement damage** is often observed in a structure supported on dried-out soil. Drying of foundation soils is commonly caused by extensive drought-like conditions, maturing trees and vegetation and leaking subfloor heating, ventilation, and air conditioning systems.



. Maturing Trees and Vegetation

Maturing trees, bushes and other vegetation in close proximity to a home or building are a common cause of settlement. As trees and other vegetation mature, their demand for water also grows. The root systems continually expand and can draw moisture from the soil beneath the foundation. Again, clay-rich soils shrink as they lose moisture, resulting in settlement of overlying structures. Many home and building owners often state that they did not have a settlement problem until decades after the structure was built.

Foundations closer to the surface are more often affected by soil dehydration due to tree roots than are deep, basement level foundations. As a general rule, the diameter of a tree's root system is at least as large as the tree's canopy.

Soil Consolidation

Consolidation occurs when the weight of a structure or newly-placed fill soils compress lower, weak clayey soils. The applied load forces water out of the clay soils, allowing the individual soil particles to become more densely spaced. Consolidation results in downward movement or settlement of overlying structures. Settlement caused by consolidation of foundation soils may take weeks, months, or years to be considered "complete."

As this occurs, the foundation will experience downward movement -- sometimes at an uneven rate. This leads to cracks and structural damage.

Differential settlement

Differential settlement occurs when the soil beneath the structure expands, contracts or shifts away. This can be caused by drought conditions, the root systems of maturing trees, flooding, poor drainage, frost, broken water lines, vibrations from nearby construction or poorly compacted fill soil.



DIFFERENTIAL SETTLEMENT



The Leaning Tower of Pisa leans due to a faulty foundation.

Differential settlement can cause cracks in a structure's foundation and interior walls, as well as uneven settling of doors and windows. Other signs of differential settlement include tilting chimneys, exterior stairs that tilt or sink, bulging walls, leaking through openings and sunken slabs. Since soil settlement tends to be gradual, cracks due to differential settlement tend to be larger at the top, diminishing to nearly nothing at the bottom. You may also see signs of vertical movement.

The best way **to prevent differential settlement** is to analyze the soil you are planning to build on, as well as the surrounding environment. In the ideal situation, the site soils will be non-expansive, meaning they have little clays or silts. Also ideally, the structure will be laid on undisturbed, native soil. An engineer can determine the load bearing capacity of the soil and estimate settlement of the planned structure. Once these calculations have been performed, make amendments to the soil before construction begins, in order to minimize differential settlement. If it is necessary to build on disturbed soil or fill, the foundation can be built on piles which extend down to good load bearing soil.

In conclusion, you now know what differential settlement is, some common causes and signs, what to do if you suspect that it is an issue with your structure and the best strategies to avoid it in the first places. If you see cracks in a structure's foundation and interior walls, uneven settling of doors or windows, bulging walls, or tilting chimneys or exterior stairs, it is best to contact a structural engineer and schedule an onsite evaluation.

Aspects of Settlement

Uniform settlement

Differential settlement

Uniform settlement does not cause harm to the structural stability of the structure.

Differential Settlement:

Different magnitude of settlement at different points underneath a structure;

Supplementary stress and cause harmful effects- cracking; permanent; irreparable damage; ultimate yield; failure of structure.

Definition of Differential Settlement

Differential settlement refers to the unequal settling of a building's piers or foundation that can result in damage to the structure. The damage occurs when the foundation sinks in different areas at different times.

Causes

Differential settlement is primarily due to the condition of the soil upon which the structure sits. Soil has the capacity to expand or contract based upon the temperature or weather conditions. It can also shift or wash away due to poor drainage, heavy rainfall, soil drying unevenly, or changes in the water table.

Effects

The settlement causes cracks in a structure's foundation, slab or supporting piers. These cracks lead to cracks in the building's interior walls and uneven settling of the building's doors, windows and trim.

Prevention and Solution

The best way to prevent damage from differential settlement is to thoroughly analyze the soil and make necessary amendments before construction begins. It may be necessary to reinforce the structure's piers or foundations if a problem occurs after the building has been constructed.

Methods of minimizing settlement:-

Improve the soil character

Select suitable or better foundation system to distribute the structural loads as smoothly as possible on soils

Take precautions to avoid soil disturbances in the surrounding of structures for also below the structural foundations including any vibratory motion disturbances

Tightening loose sand, consolidating soft clays, grouting and freezing or solidifying soil mass with chemicals - all weak pockets or uneven soil layers are made to have homogeneous and isotropic medium – distribute the pressure evenly **to avoid differential settlement.**

Soil nailing, micro pile, geotextile membrane, reinforcing of soils, geogrid reinforcement laying in embankment soil fill -**reduce long term settlement** □

Compaction by roller, vibratory roller, vibrofloatation & compaction by preloading, sand drain provisions to accelerate consideration- **long term & immediate settlement shall be minimized** Providing stone column in loose soil, lime sand mix compaction piles, lime clay mix

piles, cement clay mix, cement fly ash soil stabilization **reduce settlement in soft clay for loose sand**. Water loving trees suck water & Moisture from soil up to 3m deep, Selection of foundation & verendal systems framed foundation in expansive soils **to minimize different settlement**

Organize spacing of footings – footing interface problem Raft foundation – shallow depth

Pile group, Spacing of piles, no of piles in group and pattern of pile lay out contribute, Avoid adjacent area excavation below foundation level, providing storm water discharge channel. Providing apron and avoiding or taking precautions for soil subsidence due to tunnel or pipe line

Selection of raft or pile, footing framing or shear wall providing ground beam, grade beam, plinth

beam, continuous lintel, reinforced continuous stripes at all opening level, sill level at window bottom, reinforce brick masonry

Slab on grade like systems compacting in layers the basement fill, lime water treatment in clay below strip footing.

Total Settlement

Total foundation settlement can be divided into three different components, namely Immediate or elastic settlement, consolidation settlement and secondary or creep settlement as given below.

$$S = S_i + S_c + S_s$$

Here, S = Total Settlement

S_i = Immediate / Elastic Settlement S_c = Consolidation Settlement

S_s = Secondary Settlement

The components of settlement of a foundation are:

Immediate settlement

Consolidation Settlement, and

Secondary compression (creep) $\Delta H = \Delta H_i + U \Delta H_c + \Delta H_s$

ΔH = total settlement, ΔH_c = consolidation settlement, ΔH_s = secondary compression, U

= average degree of consolidation. Generally, the final settlement of a foundation is of interest and U is considered equal to 1 (i.e. 100% consolidation)

Immediate Settlement

Immediate settlement takes place as the load is applied or within a time period of about 7 days.

Predominates in cohesion less soils and unsaturated clay

Immediate settlement analysis are used for all fine-grained soils including silts and clays with a degree of saturation < 90% and for all coarse grained soils with large coefficient of permeability (say above 10.2 m/s)

Consolidation Settlement (ΔH_c)

Consolidation settlements are time dependent and take months to years to develop. The leaning tower of Pisa in Italy has been undergoing consolidation settlement for over 700 years. The lean is caused by consolidation settlement being greater on one side. This, however, is an extreme case. The principal settlements for most projects occur in 3 to 10 years.

Dominates in saturated/nearly saturated fine grained soils where consolidation theory applies. Here we are interested to estimate both consolidation settlement and how long a time it will take or most of the settlement to occur.

Secondary Settlement/Creep (ΔH_s)

Occurs under constant effective stress due to continuous rearrangement of clay particles into a more stable configuration.

Predominates in highly plastic clays and organic clays.

Immediate settlement of cohesive soils

Immediate settlement in cohesive soil may be estimated using elastic theory, particularly for saturated clays, clay shales, and most rocks. The linear theory of elasticity is used to determine the elastic settlement of the footing on saturated clay. **Schleicher** (1926) gave the formula for the vertical settlement under a uniformly distributed flexible area

$$1 - \mu^2$$

$$S_i = qB \frac{1 - \mu^2}{E_s}$$

$$I_w$$

$$E$$

$$s$$

Where q = intensity of contact pressure in units of E_s (Undrained Modulus of Elasticity) B = least lateral dimension of contributing base area in units of S_i E_s = modulus of elasticity of soil,

μ = Poisson's ratio of Soil. (0.5 for saturated clay) I_w = Influence factor

The value of E_s can be determined from stress-strain curve obtained from a triaxial consolidated –undrained test, unconfined compression tests, and in-situ tests like SPT, CPT, Plate load tests, Pressure meter etc. The value of influence factor I_w for a saturated clay layer of semi- infinite extent can be obtained from the table 3.1

Shape	Flexible Footing			Rigid Footing
	Centre	Corner	Average	
Circle	1	0.64	0.85	0.79
Square	1.12	0.56	0.95	0.82
Rectangle				
L/B=1.5	1.36	0.68	1.20	1.06
L/B=2.0	1.53	0.77	1.31	1.20
L/B=2.0	1.78	0.89	1.52	1.42
L/B=5.0	2.10	1.05	1.83	1.70
L/B=10	2.52	1.26	2.25	2.10
L/B=100	3.38	1.69	2.96	3.40

Table 3.1 Value of influence factor

SHALLOW FOUNDATION

TYPES OF SHALLOW FOUNDATIONS

Strip Footing: A strip footing is provided for a load-bearing wall. A strip footing is also provided for a row of columns which are so closely spaced that their spread footings overlap or nearly touch each other.

Spread or Isolated Footing: A spread footing (or isolated or pad) footing is provided to support an individual column. A spread footing is circular, square or rectangular slab of uniform thickness. Sometimes, it is stepped or hunched to spread the load over a large area.

Combined Footing: A combined footing supports two columns. It is used when the two columns are so close to each other that their individual footings would overlap. A combined footing is also provided when the property line is so close to one column that a spread footing would be eccentrically loaded when kept entirely within the property line. By combining it with that of an interior column, the load is evenly distributed. A combined footing may be rectangular or trapezoidal in plan.

Strap or Cantilever footing: A strap (or cantilever) footing consists of two isolated footings connected with a structural strap or a lever. The strap connects the two footings such that they behave as one unit. The strap is designed as a rigid beam.

Mat or Raft Foundations: A mat or raft foundation is a large slab supporting a number of columns and walls under the entire structure or a large part of the structure. A mat is required when the allowable soil pressure is low or where the columns and walls are so close that individual footings would overlap or nearly touch each other. Mat foundations are useful in reducing the differential settlements on non-homogeneous soils or where there is a large variation in the loads on individual columns.

ASSUMPTIONS IN CONVENTIONAL DESIGN OF RAFT FOUNDATION:

In the conventional method of design, the raft is assumed to be infinitely rigid and the pressure distribution is taken as linearly varying.

The assumption is valid when the raft rests on soft clay which is highly compressible and the eccentricity of the load is small.

In case when the soil is stiff or the eccentricity is large, the method does not give accurate results.

Rectangular Combined Footings

Space restrictions or architectural features may require one footing to carry at least two column loads as shown in given Fig.

Conventional design and analysis are based on the assumption that the footing is infinitely stiff and that stress distribution on the base of the footing is planar

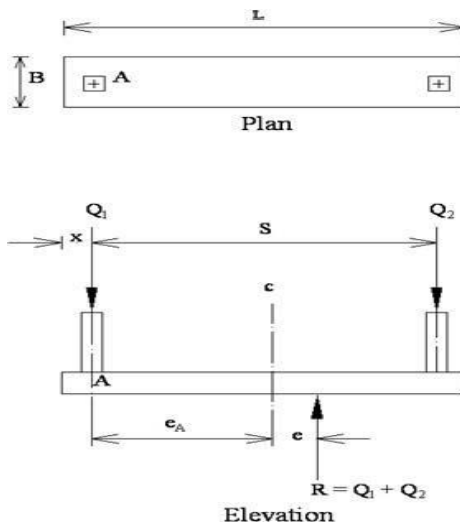

Design steps:

1. Assume Q_1 , Q_2 and S are known; therefore $\Sigma Q = Q_1 + Q_2$
2. Find the base area of the footings, $A = Q / q_{na}$, where q_{na} is the allowable soil pressure.
3. Locate the line of action of the resultant of the column loads measured from one of the column, centre of gravity of the load $x = (Q_2 \times c/c \text{ distance}) / Q$: the location of the resultant force ΣQ with respect to any point may be obtained by taking moments about that point.
4. For uniform stress distribution, the required length L of the footing is: $L = 2(x + b^1)$
5. The required width B of the footing is: $B = \text{Area} / L = (Q_1 + Q_2) / (q_{all} \times L)$
6. Actual allowable soil pressure

$$q_o = Q / A_o \text{ Where } A_o = B \times L$$

Design of Combined Footings by Rigid Method (Conventional Method)

The rigid method of design of combined footings assumes that

1. The footing or mat is infinitely rigid; hence, the deflection of the footing or mat does not influence the pressure distribution,
2. The soil pressure is distributed in a straight line or a plane surface such that the centroid of the soil pressure coincides with the line of action of the resultant force of all the loads acting on the foundation.

Design of Combined Footings

Two or more columns in a row joined together by a stiff continuous footing form a combined footing as shown in Fig. 3.3(a). The procedure of design for a combined

footing is as follows:

1. Determine the total column loads $\sum Q = Q_1 + Q_2 + Q_3 \dots$ and location of the line of action of the resultant $\sum Q$. If any column is subjected to bending moment, the effect of the moment should be taken into account.
2. Determine the pressure distribution q per lineal length of footing.
3. Determine the width B , of the footing.
4. Draw the shear diagram along the length of the footing. By definition, the shear at any section along the beam is equal to the summation of all vertical forces to the left or right of the section. For example, the shear at a section immediately to the left of Q_1 is equal to the area $abcd$, and immediately to the right of Q_1 is equal to $(abcd - Q_1)$ as shown in Fig. (a).
5. Draw the moment diagram along the length of the footing. By definition the bending moment at any section is equal to the summation of moment due to all the forces and reaction to the left (or right) of the section. It is also equal to the area under the shear diagram to the left (or right) of the section.
6. Design the footing as a continuous beam to resist the shear and moment.
7. Design the footing for transverse bending in the same manner as for spread footings.

It should be noted here that the end column along the property line may be connected to the interior column by a rectangular or trapezoidal footing. In such a case no strap is required and both the columns together will be a combined footing as shown in Fig. b. It is necessary that the center of area of the footing must coincide with the center of loading for the pressure to remain uniform.

Design of Mat Foundation by Rigid Method

In the conventional rigid method the mat is assumed to be infinitely rigid and the bearing pressure against the bottom of the mat follows a planar distribution where the centroid of the bearing pressure coincides with the line of action of the resultant force of all loads acting on the mat.

The procedure of design is as follows:

Step 1: The column loads of all the columns coming from the superstructure are calculated as per standard practice. The loads include live and dead loads.

Step 2. Centre of gravity of the mat foundation:

(1) Taking moment about X and Y direction, we can calculate \bar{X} and \bar{Y} . The line of action of the resultant of all the loads is found. However, the weight of the mat is not included in the structural design of the mat because every point of the mat is supported by the soil under it, causing no flexural stresses.

$$(2) e_x = \frac{L_x - \bar{X}}{2} \text{ and } e_y = \frac{L_y - \bar{Y}}{2}$$

Step 3. Calculate the soil pressure at desired locations by the use of

Where $Q = \sum Q =$ total load on the mat

A = total area of the mat

x, y = coordinates of any given point on the mat with respect to the x and y axes passing through the centroid of the area of the mat

$e_{x,y}$ = eccentricities of the resultant force

I_x, I_y = moments of inertia of the mat with respect to the x and y axes respectively. To calculate all the corner column loads, we have to know the coordinates from the origin.

Step 4. The mat is treated as a whole in each of two perpendicular directions. Thus the total shear force acting on any section cutting across the entire mat is equal to the arithmetic sum of all forces and reactions (bearing pressure) to the left (or right) of the section. The total bending moment acting on such a section is equal to the sum of all the moments to the left (or right) of the section.

Step 5: The pressure intensity on the strip = $\frac{Q_{ave}}{\text{Strip Area}}$

Strip Area

Step 6: Factor of safety = $\frac{Q_{ave}}{Q_1 + Q_2 + Q_3}$

$Q_1 + Q_2 + Q_3$

Numerical problems

1. A raft foundation 10m wide and 12m long is to be constructed in a clayey soil having a shear strength of 12kN/m². Unit weight of soil is 16kN/m³. If the ground surface carries a surcharge of 20kN/m². Calculate the maximum depth of foundation to ensure a factor of safety of 1.2 against base failure. N_c for clay is 5.7.

Solution:

Bearing capacity of soil for rectangular footing in cohesive soil is given by

$$q_f = cN_c(1+0.3B) + \sigma = cN_c(1+0.3B) + (\gamma D + q)$$

$$q_f = 12 \times 5.7 (1 + 0.3 \times 10) + 16 D + 20 = 105.5 + 16 D$$

Base failure will occur when q_f is equal to zero

$$D = -\frac{105.5}{16} = -6.59 \text{ (minus sign indicates that it is excavation)}$$

Therefore Critical depth = 6.59 m and Safe depth = $\frac{6.59}{2} = 3.295$ m

A Trapezoidal footing is to be produced to support two square columns of 30cm and 50cm sides respectively. Columns are 6 meters apart and the safe bearing capacity of the soil is 400kN/m². The bigger column carries 5000kN and the smaller 3000kN. Design a suitable size of the footing so that it does not extend beyond the faces of the columns

Solution:

$$\text{Area (A)} = \frac{(a+b)L}{2} = \frac{(P_1+P_2)}{q_s} \quad \text{—————}$$

$$a+b = \frac{2}{L} \times \left(\frac{5000+3000}{400} \right) = 5.882 \text{ m} \dots \dots (1)$$

$$L = 6.8 \text{ m}$$

$$\text{Also } \bar{x} = \frac{(0.5)}{2} \times (x') = 0.25 + \left(\frac{3000 \times 6.4}{5000+3000} \right) = 2.65 \text{ m}$$

$$L = 6.8 \text{ m}$$

$$\bar{y} = \frac{(2a+b)}{3} \quad \text{But } \bar{y} = \bar{x} \quad \text{—————}$$

$$\frac{(2a+b)}{3} = 2.65 \quad \dots \dots (2)$$

$$a+b = 6.8$$

$$\text{(or) } 0.831a - 0.169b = 0 \quad \text{(or) } b = 4.917a$$

Substituting these values in (1), we get $a = \frac{5.882}{5.917} = 0.994\text{m}$ and $b = 4.889\text{m}$

5.917

Hence use trapezoidal footing of size $a=1\text{m}$ and $b=4.9\text{m}$ and $L=4.889\text{m}$

3. A footing $3\text{m} \times 1.5\text{m}$ in plan transmits a pressure of 160KN/m^2 on a cohesive soil having $E = 8 \times 10^4 \text{ kN/m}^2$ and $\mu = 0.48$. Determine the immediate settlement at the centre, assuming the footing to be (a) flexible, and (b) rigid.

Solution:

$L/B = 3/1.5 = 2$. From table $I_w = 1.52$ for flexible footing and 1.22 for rigid footing.

$$(a) S_i = 160 \times 1.5 \frac{(1 - (0.48)^2)}{8 \times 10^4} \times 1.52 = 3.51 \text{ mm}$$

8×10^4

$$(b) S_i = 160 \times 1.5 \frac{(1 - (0.48)^2)}{8 \times 10^4} \times 1.22 = 2.82 \text{ mm}$$

8×10^4

Floating Foundation

General Consideration A floating foundation for a building can be defined as a foundation in which the weight of the building is approximately equal to the full weight which includes water of the soil removed from the site of the building. With reference to Fig, this principle of flotation may be explained. Fig. (a) shows a horizontal ground surface with water table at a depth d_w below the ground surface. Fig. (b) shows an excavation made in the ground to a depth D where, $D > d_w$ and Fig.

(b) shows a structure built in the excavation and completely filling it. If the weight of the building is equal to the weight of the soil and water removed from

the excavation, then it is clear that the total vertical pressure in the soil below depth D in Fig. (c) is the same as in Fig. (a) before excavation. Since there is no change in the water level, the neutral pressure and the effective pressure remain unchanged. If we could move from Fig. (a) to Fig. (c) without coming across the intermediate case of (b), the building in Fig. (c) would not settle at all, since an increase in effective vertical pressure causes settlements.

Principle of a floating foundation:

An exact balance of weight removed against weight imposed. The obtained result is zero settlement of the building

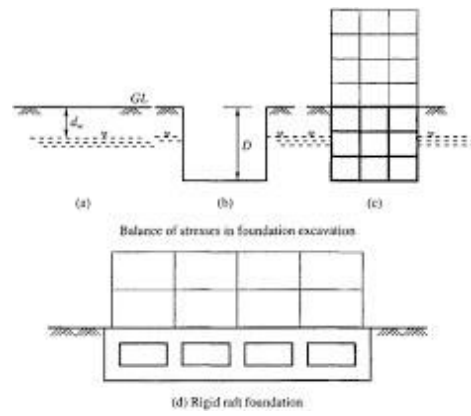

MODULE-III

PILE FOUNDATION

A **deep foundation** is a type of **foundation** which transfers building loads to the earth farther down from the surface than a **shallow foundation** does, to a subsurface layer or a range of depths.

A **pile** is a vertical structural element of a deep foundation, driven deep into the ground at the building site

Need for pile foundation

very large design loads,

a poor **soil** at shallow depth,

site constraints (like PROPERTY LINE)

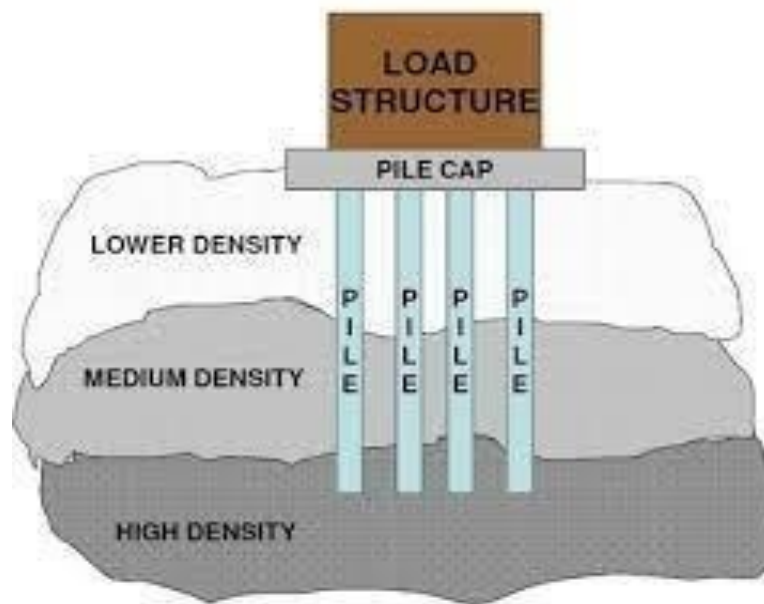

Types of Pile Foundation

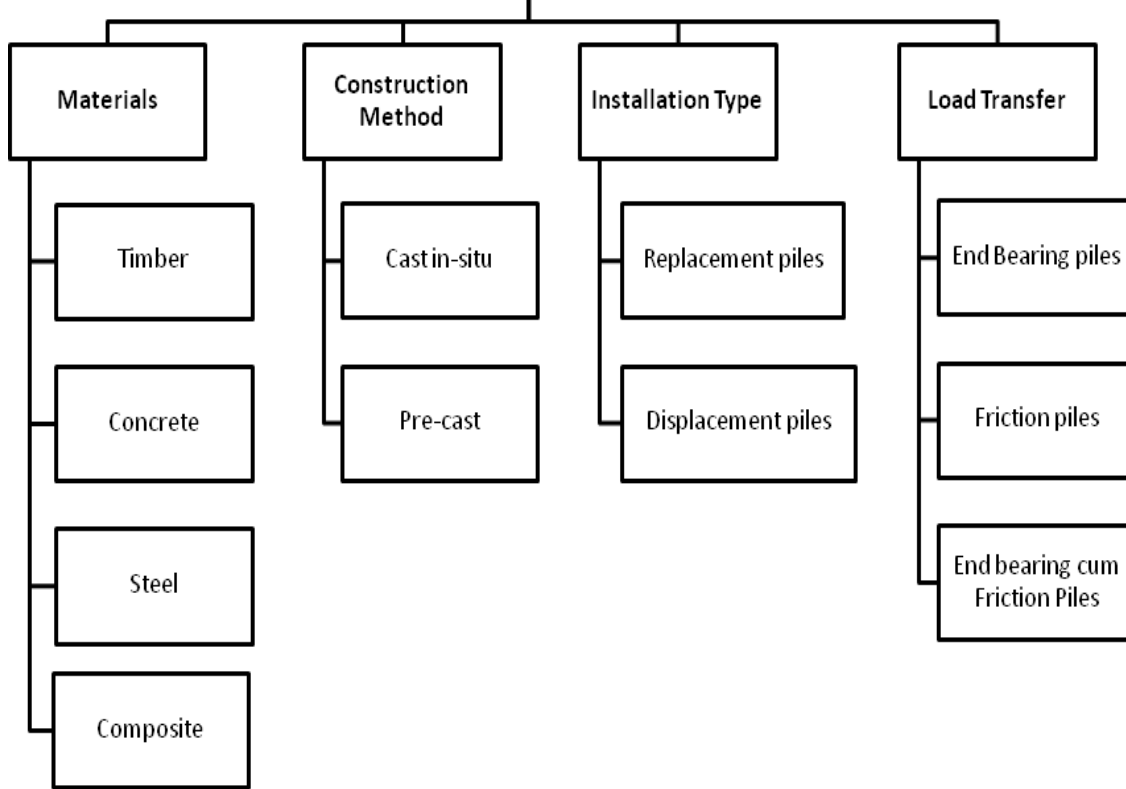

Types of Piles based on Materials

Timber piles

- Timber piles are made of tree trunks driven with small end as a point
- Maximum length: 35 m; optimum length: 9 - 20m
- Max load for usual conditions: 450 kN; optimum load range = 80 - 240 kN

Disadvantages of using timber piles:

Difficult to splice, vulnerable to damage in hard driving, vulnerable to decay unless treated with preservatives (If timber is below permanent Water table it will apparently last forever), if subjected to alternate wetting & drying, the useful life will be short, partly embedded piles or piles above Water table are susceptible to damage from wood borers and other insects unless treated.

Advantages:

Comparatively low initial cost, permanently submerged piles are resistant to decay, easy to handle, best suited for friction piles in granular material.

Steel piles

- Maximum length practically unlimited, optimum length: 12-50m
- Load for usual conditions = maximum allowable stress x cross-sectional area
- The members are usually rolled HP shapes/pipe piles. Wide flange beams & I beams proportioned to withstand the hard driving stress to which the pile may be subjected. In HP pile the flange thickness = web thickness, piles are either welded or seamless steel pipes, which may be driven either open ended or closed end. Closed end piles are usually filled with concrete after driving.
- Open end piles may be filled but this is not often necessary., dm

Advantages of steel piles:

Easy to splice, high capacity, small displacement, able to penetrate through light obstructions, best suited for end bearing on rock, reduce allowable capacity for corrosive locations or provide corrosion protection.

Disadvantages:

- Vulnerable to corrosion.
- HP section may be damaged/deflected by major obstruction

Concrete Piles

- Concrete piles may be precast, prestressed, cast in place, or of composite construction
- Precast concrete piles may be made using ordinary reinforcement or they may be prestressed.
- Precast piles using ordinary reinforcement are designed to resist bending stresses during picking up & transport to the site & bending moments from lateral loads and to provide sufficient resistance to vertical loads and any tension forces developed during driving.

- Prestressed piles are formed by tensioning high strength steel prestress cables, and

casting the concrete about the cable. When the concrete hardens, the prestress cables are cut, with the tension force in the cables now producing compressive stress in the concrete pile. It is common to higher-strength concrete (35 to 55 MPa) in prestressed piles because of the large initial compressive stresses from prestressing. Prestressing the piles, tend to counteract any tension stresses during either handling or driving.

- Max length: 10 - 15 m for precast, 20 - 30 m for prestressed
- Optimum length 10 - 12 m for precast. 18 - 25m prestressed
- Loads for usual conditions 900 for precast. 8500 kN for prestressed
- Optimum load range: 350 - 3500 kN

Advantages:

1. High load capacities, corrosion resistance can be attained, hard driving possible
2. Cylinder piles in particular are suited for bending resistance.
3. Cast in place concrete piles are formed by drilling a hole in the ground & filling it with concrete. The hole may be drilled or formed by driving a shell or casing into the ground.

Disadvantages:

1. Concrete piles are considered permanent, however certain soils (usually organic) contain materials that may form acids that can damage the concrete.
2. Salt water may also adversely react with the concrete unless special precautions are taken when the mix proportions are designed. Additionally, concrete piles used for marine structures may undergo abrasion from wave action and floating debris in the water.
3. Difficult to handle unless prestressed, high initial cost, considerable displacement, prestressed piles are difficult to splice.
4. Alternate freezing thawing can cause concrete damage in any exposed situation.

Composite piles

In general, a composite pile is made up of two or more sections of different materials or different pile types. The upper portion could be eased cast-in-place concrete combined with a lower portion of timber, steel H or concrete filled steel pipe pile. These piles have limited application and are employed under special conditions.

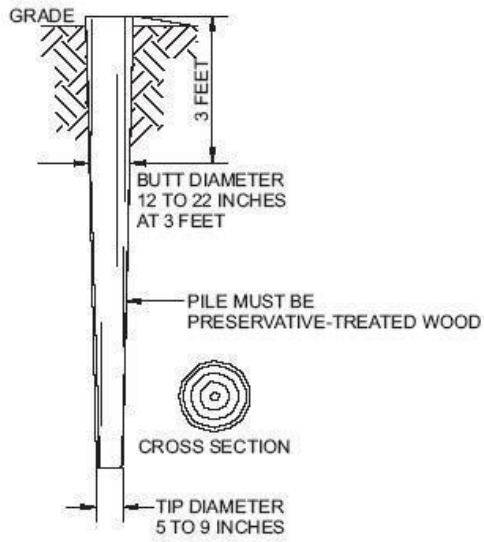

Timber pile

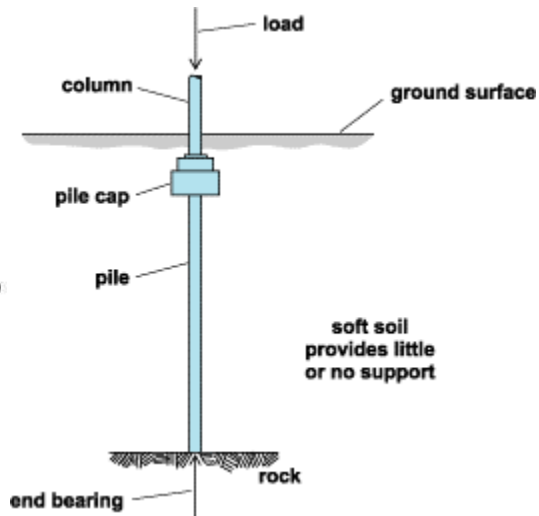

Steel pile.

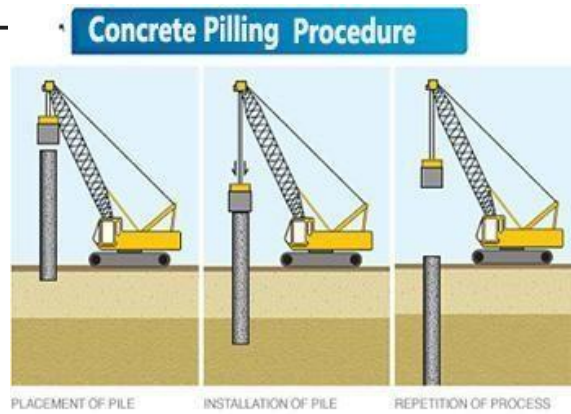
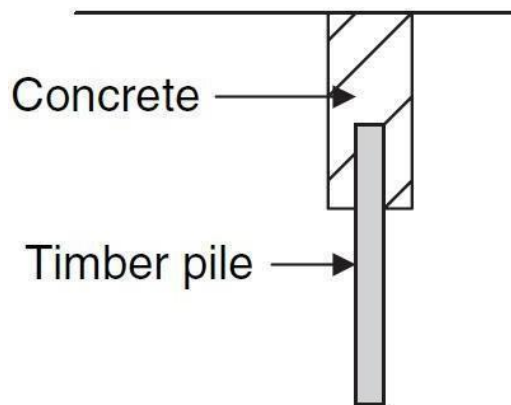

Types of Piles based on construction methods

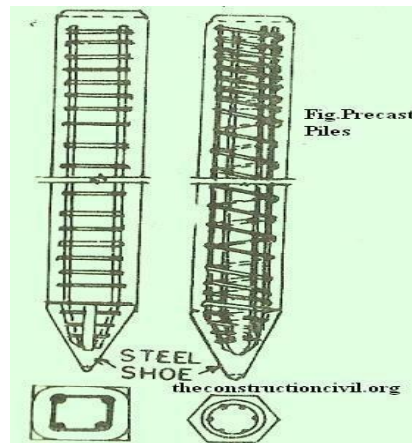

Precast Concrete Piles

May be defined as a reinforced concrete pile which is moulded in circular, square, rectangular or octagonal form. The **precast concrete piles** are cast and cured in a casting yard and then transported to the site for driving. In case space is available, pile can also be cast and cured near the site of works. They are driven in a similar manner as timber piles with the help of pile drivers. The diameter of the pile normally varies 1mm 35 cm to 65 cm and their length varies from 45 in to 30 m.

Cast-in-situ piles

Are those piles which are cast in position inside the ground. Since the **cast-in-situ piles** is not subjected to handling or driving stresses, it is not necessary to reinforce the pile in ordinary cases or in places where the pile is completely submerged in the soil. Reinforcements are necessary to be provided in a **cast-in-situ piles**, when the pile acts as a column and is subjected to lateral forces. **Cast-in-situ piles** can be divided into two types. In one the metallic shell of the pile is permanently left in place inside the ground along with the core while in the other type the outer shell is withdrawn.

2. Types of Piles based on installation type.

Piling techniques can be split into 2 categories;

Displacement piling technique

Replacement piling technique

In simple terms, during the **displacement piling method**, piles are driven into the ground pushing the ground out of the way, as you would see in sheet piling. Displacement piling is good for e.g. contaminated sites where it costs a lot to take the spoil away.

Using the **replacement piling method**, muck is dug out and replaced with the pile. We can use far bigger piles using replacement piling.

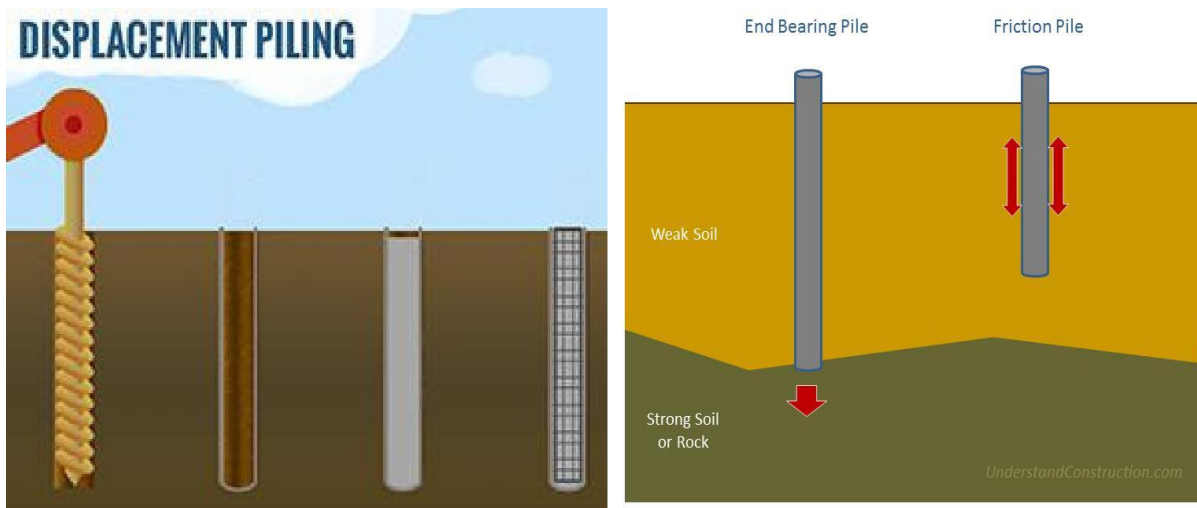

Types of Piles based on load transfer.

End bearing piles.

In end bearing piles, the bottom end of the pile rests on a layer of especially strong soil or rock. The load of the building is transferred through the pile onto the strong layer

Friction piles

Friction piles work on a different principle. The pile transfers load of the building to the soil across the full height of the pile by friction.

Classification based on method of installation:

Bored piles:

Bored piles are constructed in pre-bored holes either using a casing or by circulating stabilizing agent like bentonite slurry. The borehole is then filled with concrete after placing the reinforcement. The advantage of bored pile is that there is no damage due to handling and driving which is common in driven piles.

Bored piles are of following types:

Small diameter piles-up to 600 mm diameter; large diameter piles-diameter greater than 600mm; under reamed piles.

Driven piles:

Driven piles may be of concrete, steel or timber. These piles are driven into the soil by the impact of hammer. Boring is not required for this type of piles. When a pile is driven into granular soils it densifies the soil and increases strength of soil. But when a pile is driven in saturated clay, the soil instead of being compacted gets remolded with reduction in strength.

Driven and cast-in-situ piles:

It is a type of driven pile. They are constructed by driving a steel casing in to the ground. The hole is then filled with concrete by placing the reinforcement and the casing is gradually lifted.

(c) Classification based on the function:

Piles are of following types based on its use:

End bearing piles:

The piles which transfer its load to a hard and relatively incompressible stratum like rock or dense sand are called end bearing piles. These piles derive its bearing capacity from end

bearing at the pile tip.

Friction piles:

The piles which do not rest on hard stratum but derives its carrying capacity from skin friction or adhesion between the pile surface and surrounding soil are called friction piles.

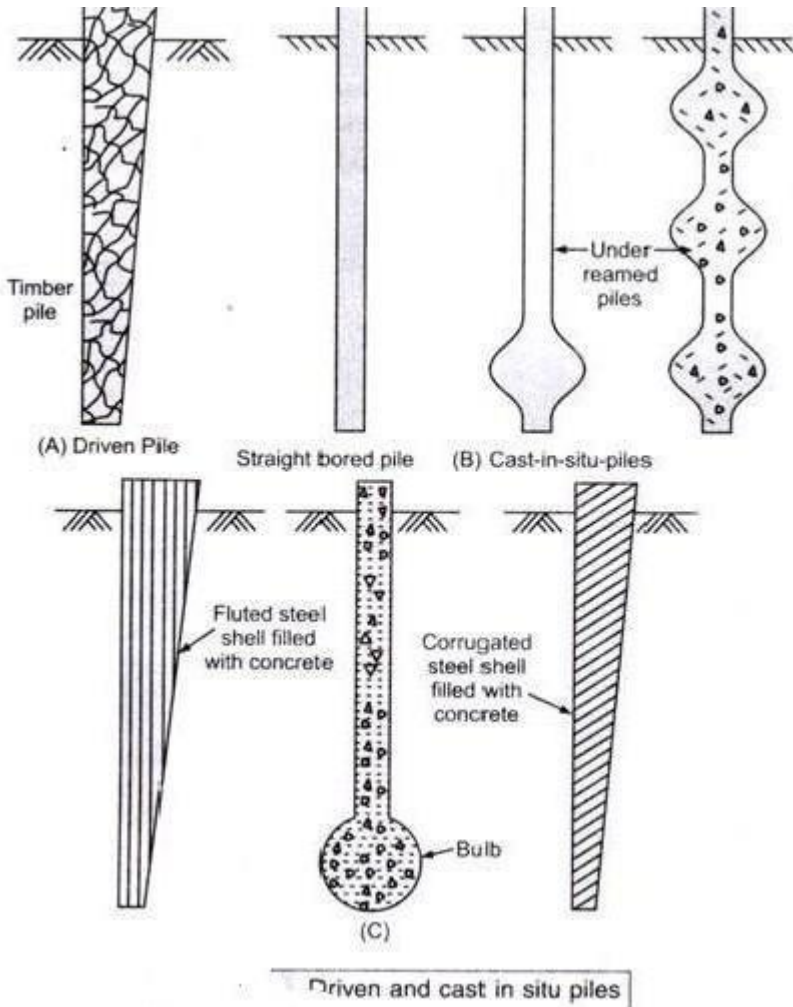

Tension pile:

Tension piles are also called uplift piles. These piles are used to anchor down the structures subjected to uplift due to hydrostatic pressure.

Compaction piles:

These piles are used to compact loose granular soil to increase its bearing capacity. Compaction piles do not carry load and hence they can be of weaker material. Sand piles can be used as compaction piles.

Anchor piles:

These piles are used to provide anchorage against horizontal pull from sheet piling.

Fender piles and dolphins:

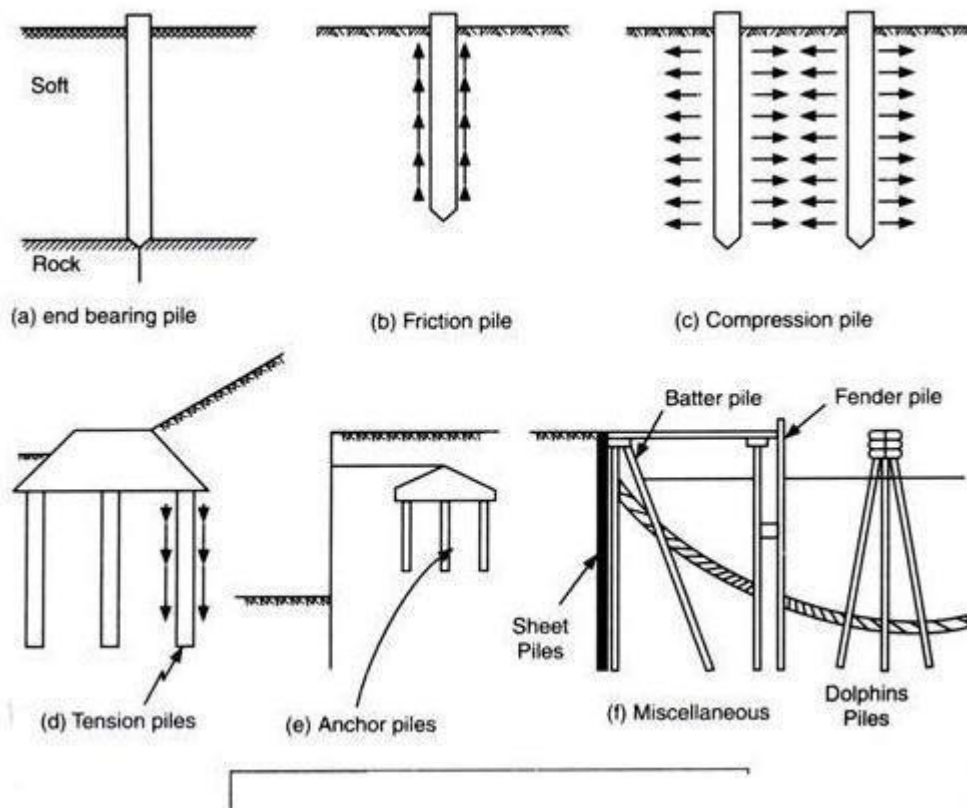

Fender piles and dolphins are used to protect water front structure from impact of any floating object or ship.

Piles based on uses

Selection of pile foundation

Selection of pile types and length depends on following conditions:

- Soil conditions
- Loads from structures Nature of loads
- Number of piles to be used Cost of construction

If hard soil is available at deeper levels of earth, then there is a need of some source that can transfer the load of the structures on the deep hard soil strata. This source can be said to be as the deep foundation. Pile foundation is a type of foundation in which pile is usually used as the source to transfer the load to deep soil levels. **Piles are long and slender members that transfer the load to hard soil ignoring the soil of low bearing capacity. Transfer of load depends on capacity of pile.** There is a need that pile should be strong enough to transfer the whole load coming on it to underlying hard strata. For this purpose, pile design is usually given much consideration. Depending on the load, type of material is usually selected for the piles.

Factors affecting the selection of piles.

- Length of pile in relation to load and soil condition Behavior of structure
- Availability of material In locality of construction Type of loading
- Ease of maintenance Availability of funds Factors causing damage Cost of piles

Load carrying capacity of pile

The **Ultimate load carrying capacity** of a pile is defined as the maximum load which can be carried by a pile and at which the pile continues to sink without further increase in load.

The **allowable load** is the load which the pile can carry safely which can be determined from the ultimate load carrying capacity divided by suitable factor of safety

Following are general methods available to establish load capacity:

Static Analysis

Dynamic Analysis

Pile Load Testing

Correlation with field tests (SPT, CPT etc)(Penetration tests)

Dynamic formulae are used for driven piles. Static formulae are used **both** for bored and driven piles. Load testing is the most reliable method to determine the load capacity of the pile in the field.

They should be performed on all piling projects. However, they are considerably more expensive than the other methods used to determine pile capacity, and economic considerations sometimes preclude their use on projects.

Field tests like SPT, CPT are also used to correlate to load carrying capacity particularly for cohesion less soils.

Static method

Based on the assumption that the ultimate bearing capacity Q_{up} of a pile is the sum of the total ultimate skin friction R_f and the total ultimate point or end bearing resistance R_p

$$Q_{up} = R_f + R_p \quad \text{or}$$

$$Q_{up} = A_s \cdot r_f + A_p \cdot r_p$$

A_s = surface area of pile upon which the skin friction acts.

A_p = area of cross section of pile on which bearing resistance acts. r_f = average skin friction

r_p = unit point or toe resistance.

A factor of safety of 2.5 or 3 may be adopted for finding the allowable load.

For cohesive soil,

r_f = average skin friction along the length of the pile

$= m c'$

r_p = point resistance

$= C_p N_c$

$= 9 C_p$.

$Q_{up} = m c' A_s + 9 C_p A_p$

Where m = adhesion coefficient

C_p = average undrained cohesion of soil @ pile tip
 $c' = c_p = q_u / 2$

Dynamic formulae.

Engineering News Formula

As per the Engineering News formula the allowable load of driven pile is given by:

$$Q_a = \frac{WH}{F(S+C)}$$

Where, Q_a = Allowable load in kg W = Weight of hammer

h = Height of fall in cms

S = Final settlement per blow known as set

C = Empirical constant

(c = 2.5 cm for drop hammer and 0.25 cm for single acting and double acting hammer)

F = Factor of safety (Usually taken as 6)

Drop hammer $Q_a = \frac{WH}{6(S+2.5)}$

$6(S+2.5)$

Single acting stream hammer $Q_a = \frac{WH}{6(S+0.25)}$

$6(S+0.25)$

Double acting hammer $Q_a = \frac{(W+ap)H}{6(S+0.25)}$

=

$6(S+0.25)$

a= effective area of piston in square cm.

p= mean effective steam pressure (kg/cm²)

Hiley's Formula (IS: 2911 part-I) 1964

The relation suggested by Hiley for ultimate bearing capacity of the pile is:

$$Q_u = \frac{\eta_h W H \eta_b}{(S+C/2)}$$

Where, c = Sum of elastic compression (c = c_p + c_c + c_q) c_p = Compression of pile

c_c = Compression of pile head c_q = Compression of ground W = Weight of hammer

H = Height of fall of hammer

s = penetration or Set in cm /blow

η_h = Efficiency of hammer [65% for DAH and 100% for DH]

η_b = Efficiency of hammer blow (ratio of energy after impact to striking energy of

$$W > eP, \eta_b = (W + e^2 P) / (W + P)$$

P= Weight of pile

E= Coefficient of restitution

It should be noted that η depends on the coefficient of restitution, which is given in Table 2, η being obtained from Fig.2. Hammer coefficient is given in Table 1

Hammer	K
Drop Hammer, Winch operated	0.8
Drop Hammer, Trigger release	1.0
Single Acting Hammer	1.9
BSP Double Acting Hammer	1.0
McKiernan-Terry Diesel Hammers	1.0

Table 1 Values of Hammer Coefficient K

PILE LOAD TEST

To determine settlement under working load

To determine ultimate bearing capacity

To ascertain as a proof of acceptability

The test can be initial or routine test

The load is applied in increments of 20% of the estimated safe load. Hence the failure load is reached in 8-10 increments.

Settlement is recorded for each Settlement is recorded for each increment until the rate of

settlement is less than 0.1 mm/hr.

The ultimate load is said to have reached when the final settlement is more than 10% of the diameter or the settlement keeps on increasing at constant load. 45

After reaching ultimate load the after reaching ultimate load, the load is released in decrements of 1/6th of the total load and recovery is measured until full recovery is measured until full rebounds is established and next unload is done.

After final unload the settlement is measured for 24 hrs to estimate full elastic recovery.

Load settlement curve depends on the type of pile

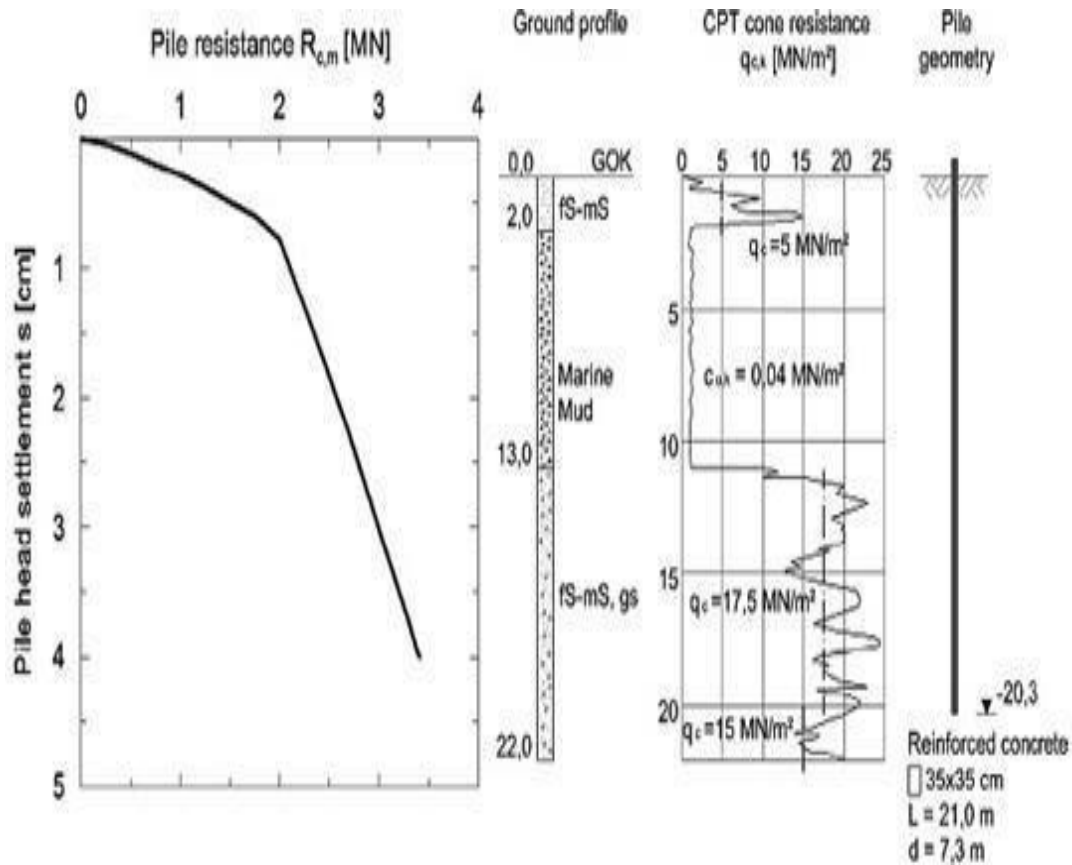

Gravity loading to take
Jack reaction

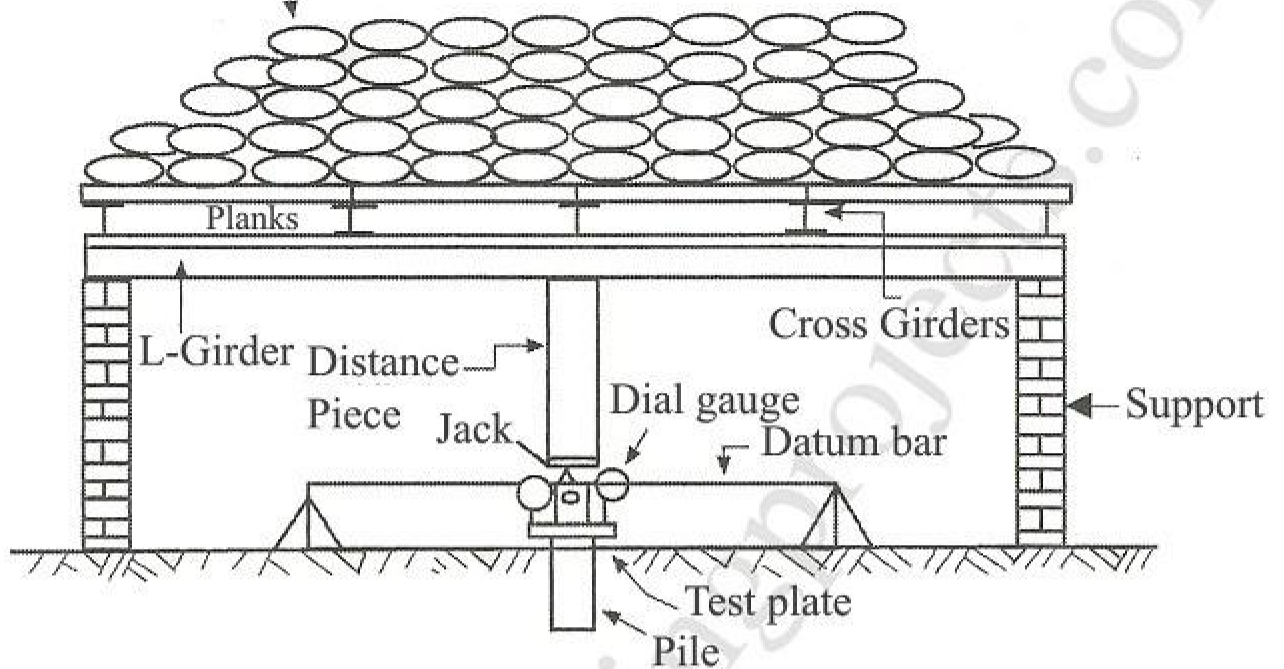

(a) Jack loading reaction by loaded platform

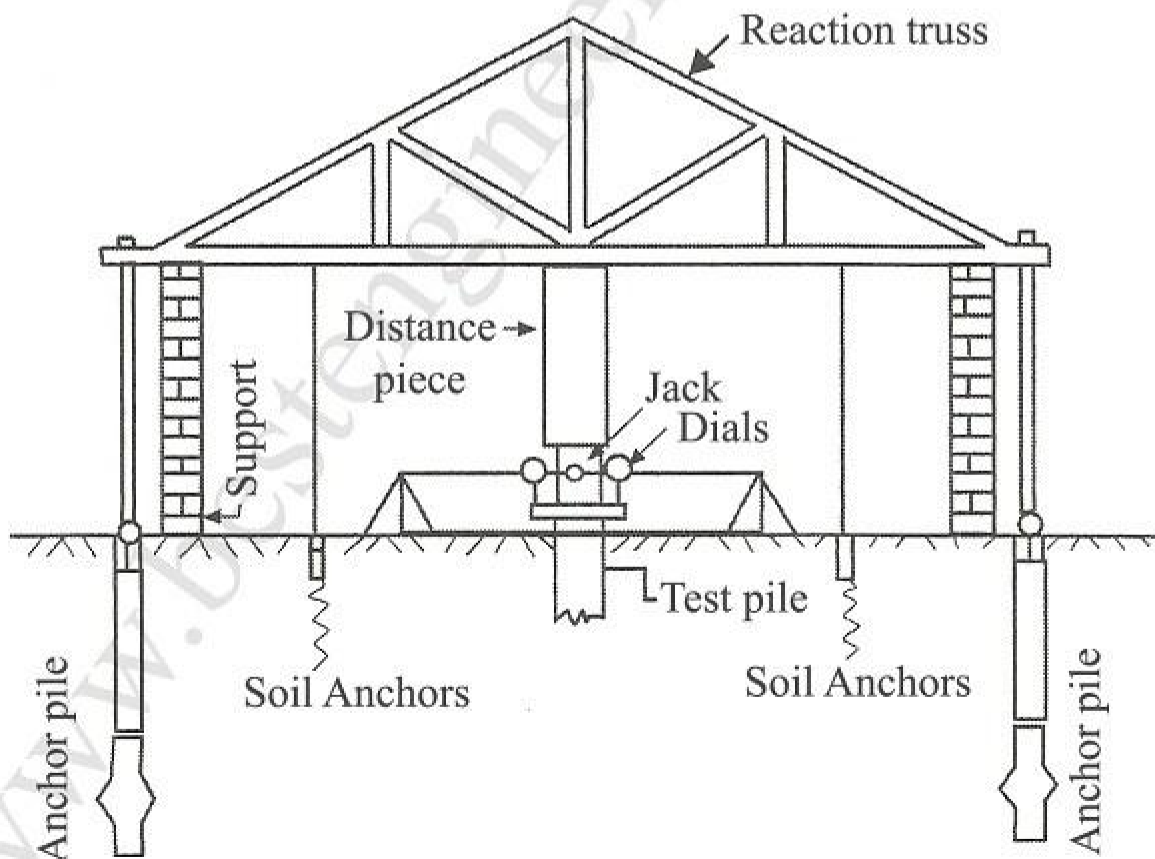

(b) Jack loading reaction by anchors

Distance of anchor piles from test pile – The distance cannot be less than 1.5 m. It should not be less than 4 times the diameter of test pile for straight pile and not less than 2 times the diameter of the bell for belled pile.

Load Application – The load is applied in the pile in the following sequence.

Load applied in increment at the rate of 25 % of working load till working load is reached

For each load increment maintain the load constant till settlement is 0.1 mm for 5 min as per IS Code, 0.1 mm for 20 min as per BS Code

Go for next loading

When working load is reached hold the load for 24 hr and unload

Reload from working load to higher loads

Hold load constant till settlement is 0.1 mm for 5 min as per IS Code, 0.1 mm for 20 min as per BS Code

Repeat the process for subsequent load increments

o Go either up to 5/2 times the working load for initial or routine test or to a settlement equal to 10 % of pile diameter for straight piles and 7.5 % of base diameter for belled pile

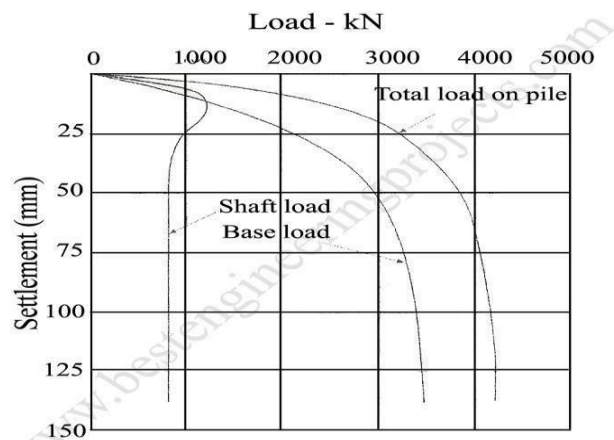

Fig 2 Load Taken by Shaft and Base

Pile group.

When several piles are clustered, it is reasonable to expect that the soil pressures produced from either side friction or point bearing will overlap.

The super-imposed pressure intensity will depend on both the pile load and spacing, and if sufficiently large the soil will fail in shear or the settlement will be excessive.

The stress intensity from overlapping stressed zones will obviously decrease with increased pile spacing s ; however, large spacing's are often impractical in a pile cap is cast over the pile group for the column base and/or to spread the load to the several piles in the group.

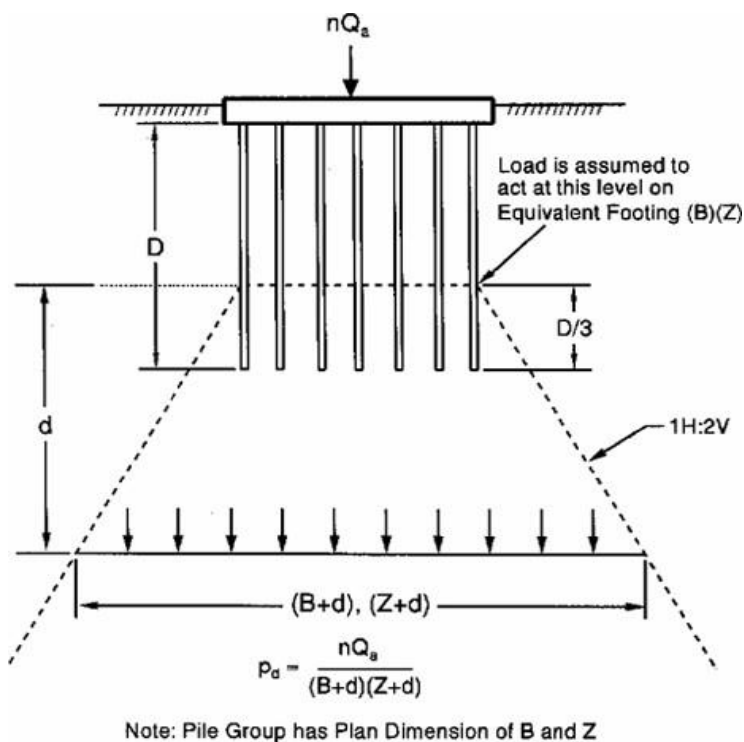

EFFICIENCY OF PILE GROUP

Capacity of pile group is the sum of the individual capacities of piles, but it is influenced by the spacing between the piles.

$$(W + eSch2 P)/((W + P))$$

Piles are driven generally in groups in regular pattern to support the structural loads. The structural load is applied to the pile cap that distributes the load to individual piles. If piles are spaced sufficient distance apart, then the capacity of pile group is the sum of the individual

$$(W + eSch2 P)/((W + P))$$

capacities of piles. However, if the spacing between piles is too close, the zones of stress around the pile will overlap and the ultimate load of the group is less than the sum of the individual pile capacities specially in the case of friction piles, where the efficiency of pile group is much less.

Group action of piles is evaluated by considering the piles to fail as a unit around the perimeter of the group. Both end bearing and friction piles are considered in evaluating the group capacity. End bearing pile is evaluated by considering the area enclosed by the perimeter of piles as the area of footing located at a depth corresponding to the elevation of pile tips. The friction component of pile support is evaluated by considering the friction that can be mobilized around the perimeter of the pile group over the length of the piles as shown in figure below:

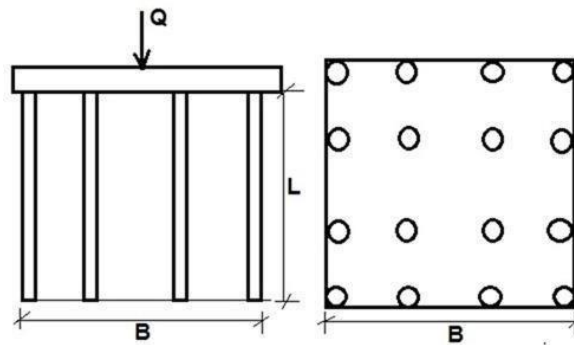

Efficiency of pile group

When closely spaced piles are grouped together it is reasonable to expect that the soil as resistance will overlap.

The bearing capacity of pile group may or may not be the sum of the bearing capacity of individual piles constituting the group.

Theory and tests have shown the total bearing capacity Q_{ug} of a group of friction piles particularly in clay may be less than the product of the friction bearing value Q_{up} of individual pile multiplied by the number of piles in a group.

There is no reduction in the case of end bearing piles.

For combined end bearing and friction piles only the load carrying capacity of the frictional portion is reduced.

A method of estimating the bearing capacity of a pile group of friction piles is to multiply the quantity nQ_{up} by a reduction factor called the efficiency of pile group.

$$(W + eSch2 P)/((W + P))$$

$$Q_{ug} = n \cdot Q_{up} \cdot \eta_g$$

Q_{ug} = load carried by group of friction piles Q_{up} = load carried by each friction piles

n = number of piles

η_g = efficiency of pile group.

The efficiency of the pile group depends upon the following factors

Characteristics of pile

Spacing of pile

Total number of piles

No of formulae are available for finding the efficiency of pile.

Pile Spacing

The spacing of piles depends upon the method of installing the piles and the type of soil. The piles can be driven piles or cast-in-situ piles. When the piles are driven there will be greater overlapping of stresses due to the displacement of soil. If the displacement of soil compacts the soil in between the piles as in the case of loose sandy soils, the piles may be placed at closer intervals.

When piles are placed in a group, there is a possibility the pressure isobars of adjacent piles will overlap each other as shown in **Fig. b**. The soil is highly stressed in the zones of overlapping of pressures. With sufficient overlap, either the soil will fail or the pile group will settle excessively since the combined pressure bulb extends to a considerable depth below the base of the piles. It is possible to avoid overlap by installing the piles further apart as shown in **Fig. c**. Large spacing are not recommended sometimes, since this would result in a larger pile cap which would increase the cost of the foundation.

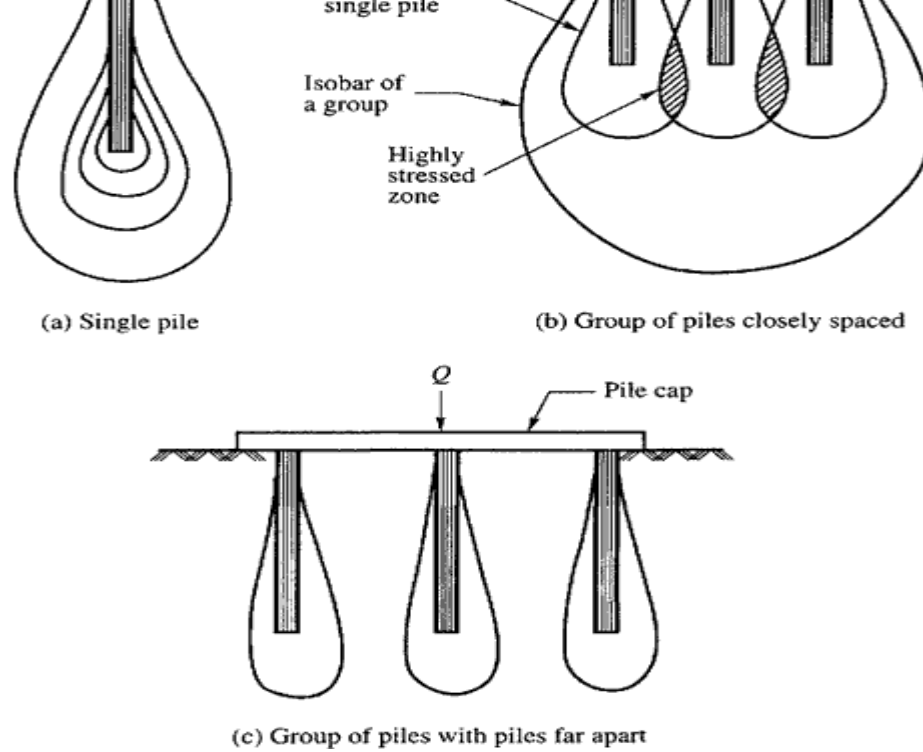

The spacing of piles in a group depends upon many factors such as

- Overlapping of stresses of adjacent piles,
- Cost of foundation,
- Efficiency of the pile group.

The minimum allowable spacing of piles is usually stipulated in building codes. The spacing for straight uniform diameter piles may vary from 2 to 6 times the diameter of the shaft. For friction piles, the minimum spacing recommended is $3d$ where d is the diameter of the pile. For end bearing piles passing through relatively compressible strata, the spacing of piles shall not be less than $2.5d$.

For end bearing piles passing through compressible strata and resting in stiff clay, the spacing may be increased to $3.5d$. For compaction piles, the spacing may be $1d$. Typical arrangements of

$$(W + eSch2 P)/((W + P))$$

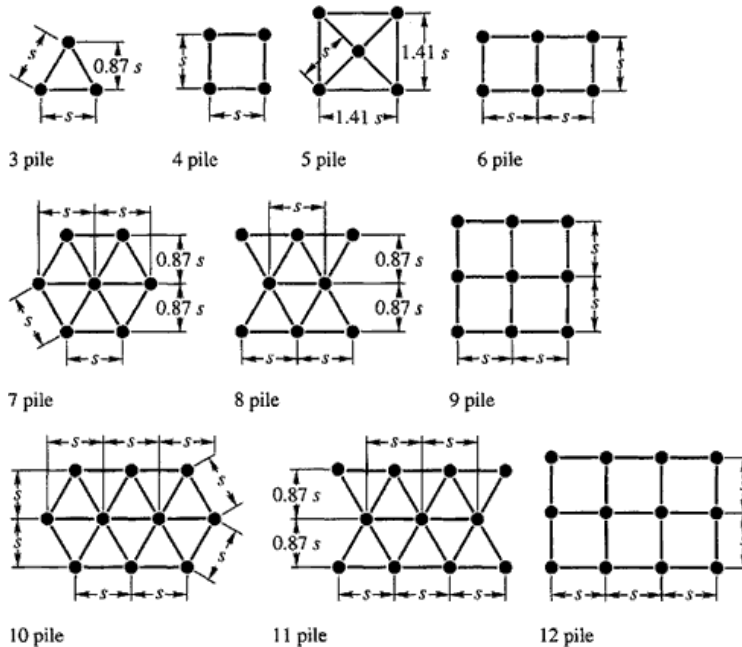

piles in groups are shown in Fig.

Negative Skin Friction

Pile installed through compressive soils can experience “down drag” forces or negative resistance along the shaft, which results from downward movement (settlement) of adjacent soil. Negative resistance results primarily from consolidation of soft deposits caused by dewatering or fill placement.

$$(W + eSch2 P)/((W + P))$$

Negative skin friction (NSF) is in fact a downward friction imposed on foundation piles as a result of subsoil settlement. It needs only few millimeters of relative displacement between the settling subsoil and the pile shaft surface, which is not uncommon to have relative displacement at the pile-soil interface more than these values in normal subsoil settlement problem, to fully mobilize the shaft resistance in either upward or downward directions.

There are five probable, but not limited to, reasons of existence of NSF, namely,

Self-weight of unconsolidated recent fill,

Surcharge-induced consolidation settlement,

Consolidation settlement after dissipation of excess pore pressure induced by pile driving,

Lowering of groundwater level,

Collapse settlements due to wetting of unsaturated fill, and

Crushing of crushable subsoil under sustained loading, causing subsoil settlement

For individual piles the magnitude of negative friction Q_{nf} may be taken as follows For cohesive soils $=Q_{nf} = p.c.L_f$

For granular soils $= \frac{1}{2} L_f^2 \cdot p \cdot r \cdot K \cdot f$

P perimeter of the pile. r- unit weight to C cohesion

K earth pressure

F-coefficient of friction.

When the fill starts consolidating under its own overburden pressure, it develops a drag on the surface of the pile. This drag on the surface of the pile is called '*negative friction*'. Negative friction may develop if the fill material is loose cohesion less soil. Negative friction can also occur when fill is placed over peat or a soft clay stratum as shown in **Fig.C**.

The superimposed loading on such compressible stratum causes heavy settlement of the fill with consequent drag on piles.

Negative friction may develop by lowering the ground water which increases the effective stress causing consolidation of the soil with resultant settlement and friction forces being developed on the pile.

Negative friction must be allowed when considering the factor of safety on the ultimate carrying capacity of a pile. The factor of safety, F_s , where negative friction is likely to occur may be written as

$$(W + eSch2 P)/((W + P))$$

$$F_s = \frac{\text{Ultimate carrying capacity of a single pile or group of piles}}{\text{Working load} + \text{Negative skin friction load}}$$

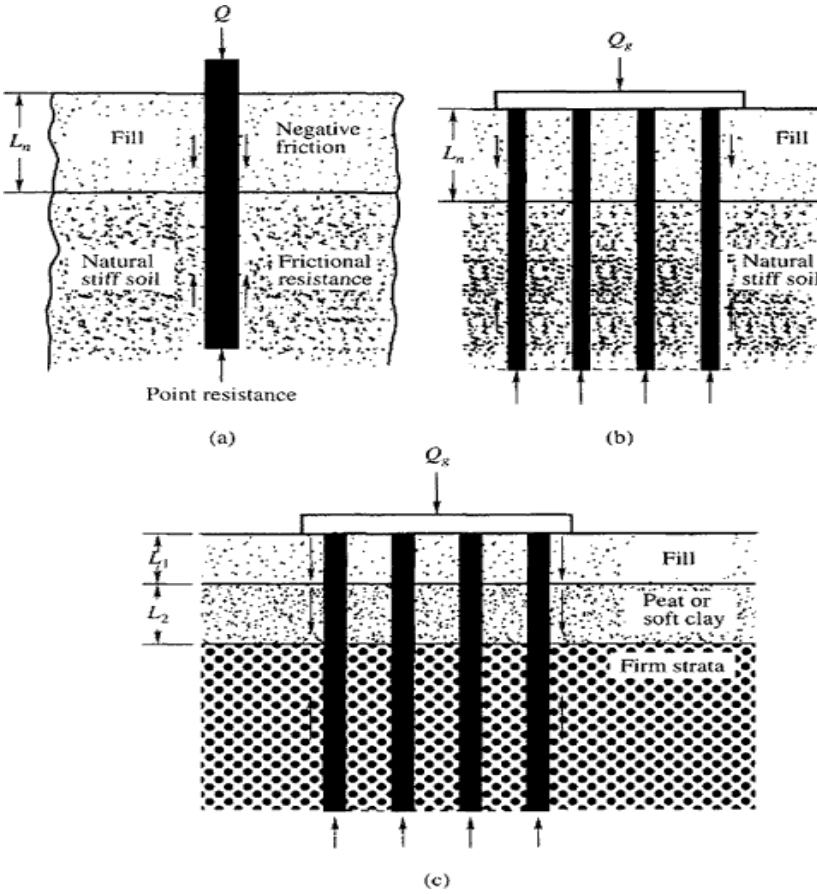

$$(W + eSch2 P)/((W + P))$$

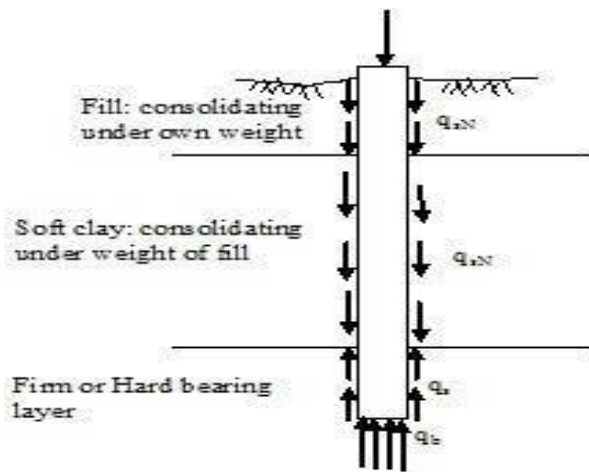

$$(W + eSch2 P)/((W + P))$$

Problem 1

A group of 9 piles arranged in a square pattern with diameter and length of each pile as 25cm and 10m respectively, is used as a foundation in soft clay deposit. The unconfined compressive strength of clay as 120kN/m^2 and the pile spacing as 100cm c/c. Find the load capacity of the group. Assume the bearing capacity factor as $(N_c) 9$ and adhesion factor $(m) = 0.75$. Factor of safety of 3.5 may be taken.

Solution

Formula used: $Q_{up} = A_p r_p + A_s r_f$

Pile acting individually, $C = 120/2 = 60\text{kN/m}^2$

$$A_p = \frac{\pi d^2}{4} = 0.049\text{m}^2 \quad r_p = c \quad N_c = 60 \times 9$$

$$A_s = \pi dl$$

$$r_f = m c$$

$$Q_{up} = 380 \text{ kN}$$

Load capacity of 9 piles = $9 \times 380 = 3419\text{kN}$

Pile acting on a group,

$$B = 2s + d = 2.25\text{m}$$

$$A_p = B^2 = (2.25 \times 2.25) \text{m}^2 \quad r_p = 9 c = 60 \times 9$$

$$A_s = 4B l = 4 \times 2.25 \times 10$$

$$r_f = c = 60 \text{ kN/m}^2 \text{ a}$$

$$(W + eSch2 P)/((W + P))$$

$$Q_{ug} = 8133 \text{ kN}$$

Minimum of Q_{up} and Q_{ug} is $Q_n \text{ min} = 3419 \text{ kN}$

$$Q = Q_u \text{ min}$$

F

$$a \quad \frac{\quad}{\quad} = 3419 / 23.5 = 1367 \text{ kN}$$

A group of 16 piles of 600mm diameter is arranged in a square pattern with the c/c spacing of 1.2m. The piles are 10m long and are embedded in soft clay with cohesion of 30kN/m². Bearing resistance may be neglected for the piles. Adhesion factor is 0.6. Determine the Ultimate load capacity of the pile group.

Solution:

Neglecting the bearing resistance, $Q_{up} = A_s r_f$

Pile acting individually,

$$Q_{un} = n Q_{up} = n(A_s r_f)$$

$$A_s = \pi dl = \pi \times 0.6 \times 10 = 18.84 \text{ m}^2 \quad r_f = \alpha c = 0.6 \times 30 = 18 \text{ kN/m}^2 \quad Q_{un}$$

$$= 16(18.84 \times 18) = 5428.7 \text{ kN}$$

2. Pile acting on a group,

$$B = 2 \times 1.2 + 0.6 = 4.2 \text{ m.}$$

$$Q_{ug} = A_{sg} r_f$$

$$A_{sg} = 4 \times B \times L = 4 \times 4.2 \times 10 = 16.8 \text{ m}^2$$

$$r_f = c = 30 \text{ kN/m}^2 \quad Q_{ug} = A_{sg} r_f$$

$$= 16.8 \times 30$$

$$= 5040 \text{ kN}$$

MODULE-IV

The art of selecting, designing, and constructing the elements that transfer the weight (Weight may also include horizontal loads in addition to vertical loads) of a structure to the underlying soil or rock. A foundation is interfacing element between the superstructure and the underlying soil or rock. The loads transmitted by the foundation to the underlying soil must not cause soil shear failure or damaging settlement of the superstructure.

The term “foundation engineering” is used to include the design of foundations for buildings and other structures and also for such non foundation problems as designs of retaining walls, bulkheads, cofferdams, tunnels, and earth dams, as well as the design of natural slopes, dewatering of soils, and stabilization of soils mechanically and chemically.

The geotechnical engineer is responsible for all geotechnical requirements of all types of structures. For any construction project, the geotechnical engineer’s responsibilities include:

developing a soil exploration plan;

preparing the Preliminary Geotechnical Report (PGR) to assist in the selection of foundation type and to perform a preliminary seismic analysis/evaluation;

identifying the proposed boring locations and anticipated foundation type;

Assisting the Construction engineers by preparing pile driving criteria, reviewing pile installation plans and determining acceptance of as-built piles.

Also assisting bridge designer in determining pile production lengths based on field load tests.

PROPERTIES OF FOUNDATION

Strength: Load bearing capacities: Crystalline rocks (very strong - 12,000), sedimentary rocks (intermediate - 6,000) and other types of soils (relatively lower -2,000 to 3,000)

Stable under loads (creep, shrinkage and swelling)

Drainage characteristics: Porosity and permeability

Soil property estimation: Subsurface exploration (test pits - less than 8 ft in depth; borings - greater than 8 ft) - Estimate level of water table - Testing of soil sample in laboratory for various properties: Particle size distribution, Liquid limit, Plastic limit, Water content, Permeability, Shrinkage/ swelling, Shear/compressive strength, Consolidation (creep and settlement)

CONSTRUCTION OF FOUNDATIONS

Some amount of excavation required for every building - Top soil consisting of organic matter is removed - Below the region of soil erosion (by water and wind) & below the level of permafrost - To the required depth at which the bearing capacity necessary for the building is met - A variety of machines used for excavation - The sides of excavation too be protected from caving in by benching, sheeting (soldier beams and lagging, sheet piles, slurry walls, etc.) or bracing (cross-slot, rakers or tiebacks) - De-watering using well-points & sumps, and watertight barriers - Mixing the soil by rotating paddles

Bulldozers, Shovel dozers, Back hoes, Bucket loaders, Scrapers, Trenching machines Power shovels, Tractor-mounted rippers, Pneumatic hammers, Drop balls, Hydraulicsplitters and Blasting.

Purpose of Foundation:

All engineering structures are provided with foundations at the base to fulfill the following objectives and purposes;

To distribute the load of the structure over a large bearing area so as to bring intensity of loading within the safe bearing capacity of the soil lying underneath.

To load the bearing surface at a uniform rate so as to prevent unequal settlement.

To prevent the lateral movement of the supporting material.

To secure a level and firm bed for building operations.

To increase the stability of the structure as a whole.

Factors Affecting the Depth of Foundation

For economic consideration, the depth at which the foundation is located (i.e. D_f) is kept as small as possible. Typically it is in the range of 0.5 to 1.5 m below the ground surface for buildings that do not have a basement. For those building having a basement, D_f can be 3.5m or more. In determining D_f , the soil profile is carefully studied and the influence of the following factors accounted for.

Presence of Loose Fill

Often one encounters pockets of loose fill of recently dumped soil or construction waste at or near the ground surface. Foundations should be placed below such loose fills.

Depth of Water Table

Wherein possible, shallow foundations are not placed below the ground water level to avoid expensive de-watering costs during foundation construction.

Lateral Variability

Usually all foundations are placed at the same D_f . there are soil profiles that calls for a different D_f for different footings. For example, consider a profile in which rock exist at shallow depth and is gently sloping in some direction. In an attempt to take advantage of the high allowable soil pressure associated with placing the foundation on rock, we will have a different D_f for each footings so that each can be placed on the rock.

Zones of Volume Change

In cold regions where temperature changes cause soil near the ground surface to go through cycles of freezing and thawing with consequent changes in soil volume, foundation are placed below the zone so affected. Similarly in swelling soils, there is a zone that undergoes volume change due to wetting and drying cycles. D_f is selected such that it is more than the thickness of this zone.

Scour

When shallow foundations are designed to be placed below the river bed for river crossing structures, one must recognize that the elevation of the river bed changes on account of scour that occurs when the water flows at high velocity such as during floods.

Soil Exploration

The knowledge of subsoil conditions at a site is a prerequisite for safe and economical design of substructure elements. The field and laboratory studies carried out for obtaining the necessary information about the surface and subsurface features of the proposed area including the position of the ground water table, are termed as soil exploration or site investigation.

The primary objectives of soil exploration are

Determination of the nature of the deposits of soil.

Determination of the depth and thickness of the various soil strata and their extent in the horizontal direction.

The location of ground water table (GWT).

Obtaining soil and rock samples from the various strata.

The determination of the engineering properties of the soil and rock strata that affect the performance of the structure.

Determination of the in-situ properties by performing field tests.

Scope of Soil Investigation

The scope of a soils investigation depends on the type, size, and importance of the structure, the client, the engineer's familiarity with the soils at the site, and local building codes. Structures that are sensitive to settlement such as machine foundations and high-use buildings usually require a thorough soils investigation compared to a foundation for a house. A client may wish to take a greater risk than normal to save money and set limits on the type and extent of the site investigation. If the geotechnical engineer is familiar with a site, he/she may undertake a very simple soils investigation to confirm his/her experience. Some local building codes have provisions that set out the extent of a site investigation. It is mandatory that a visit be made to the proposed site. In the early stages of a project, the available information is often inadequate to allow a detailed plan to be made.

A site investigation must be developed in phases.

Phases of a Soils Investigation : The soil investigation is conducted in phases. Each preceding phase affects the extent of the next phase. The various phases of a soil investigation are given below:

Phase I. Collection of available information such as a site plan, type, size, and importance of the structure, loading conditions, previous geotechnical reports, topographic maps, air photographs, geologic maps, hydrological information and newspaper clippings.

Phase II. Preliminary reconnaissance or a site visit to provide a general picture of the topography and geology of the site. It is necessary that you take with you on the site visit all the information gathered in Phase I to compare with the current conditions of the site. Here visual inspection is done to gather information on topography, soil stratification, vegetation,

water marks, ground water level, and type of construction nearby.

Phase III. Detailed soils exploration. Here we make a detailed planning for soil exploration in the form trial pits or borings, their spacing and depth. Accordingly, the soil exploration is carried out. The details of the soils encountered, the type of field tests adopted and the type of sampling done, presence of water table if met with are recorded in the form of bore log. The soil samples are properly labeled and sent to laboratory for evaluation of their physical and engineering properties.

Phase IV. Write a report. The report must contain a clear description of the soils at the site, methods of exploration, soil profile, test methods and results, and the location of the groundwater. This should include information and/or explanations of any unusual soil, waterbearing stratum, and soil and groundwater condition that may be troublesome during construction.

Soil Exploration Methods

Trial pits or test pits

Boring

probes (in situ test) and geophysical methods

Specific recommendations are made by Indian standards regarding the type, extent and details of subsurface explorations and the number, depth and spacing of boreholes for the following civil engineering works. Following is the list of various codes specified for the said purpose: Foundations of Multi-storeyed Buildings (IS: 1892, 1979)

Earth and rockfill Dams (IS: 6955, 1973) Power House Sites (IS: 10060, 1981)

Canals and Cross Drainage Works (IS: 11385, 1985) Ports and Harbours (IS: 4651 – Part 1, 1974)

The methods available for soil exploration may be classified as follows

Direct methods ... Test pits, trial pits or trenches

Semi-direct methods ... Borings

Indirect methods ... Soundings or penetration tests and geophysical methods

The direct method of soil exploration usually consists of sinking a borehole at a predetermined location to the required depth by a method suitable for the site and to obtain fairly intact samples of soils from every stratum encountered or at suitably selected depths. The samples obtained are utilized to get necessary information about the soil characteristics by means of laboratory tests.

During recent years, indirect methods of soil exploration have also been used for civil engineering structures. These methods include various sounding and geophysical methods. In sounding methods, the variation in penetration resistance of sample or cone is utilized to interpret some of the physical properties of the strata. In geophysical methods, the change in subsoil strata are identified by measuring certain physical characteristics, e.g. electrical conductance, wave velocity of subsurface deposits. In addition to these methods, projectiles, probes, and aerial photographs are also useful in interpreting the soil characteristics.

Trial pits or test pits

Applicable to all types of soils

Provide for visual examination in their natural condition

Disturbed and undisturbed soil samples can be conveniently obtained at different depths

Depth of investigation: limited to 3 to 3.5 m.

Advantages

Cost effective

Provide detailed information of stratigraphy

Large quantities of disturbed soils are available for testing

Large blocks of undisturbed samples can be carved out from the pits

Field tests can be conducted at the bottom of the pits

Disadvantages

Depth limited to about 6m

Deep pits uneconomical

Excavation below groundwater and into rock difficult and costly iv) Too many pits may scar site and require backfill soils.

Limitations

Undisturbed sampling is difficult ii) Collapse in granular soils or below ground water table

Semi Direct Methods –Boring

Boring: Making or drilling bore holes into the ground with a view to obtaining soil or rock samples from specified or known depths is called „boring“

The common methods of advancing bore holes are: Auger boring, Wash boring, rotary boring and Percussion boring.

Exploratory borings

Boring is carried out in the relatively soft and uncemented ground (engineering „soil“) which is normally found close to ground surface. The techniques used vary widely across the world.

Location, spacing and depth of borings

It depends on: i) Type of structure ii) Size of the structure iii) Weight coming from the

General guidelines for location and depth of bore holes Boreholes are generally located at The building corners The centre of the site

Where heavily loaded columns or machinery pads are proposed.

At least one boring should be taken to a deeper stratum, probably up to the bedrock if practicable other borings may be taken at least to significant stress level.

Spacing of Bore Holes – Codal Recommendations

According to IS 1892 (1979) Code of practice for subsurface investigation:

For a small building one bore hole or test pit at the centre can give necessary data

For a building covering not more than 4000 sq.m, one bore hole or test pit at each corner and one at centre is adequate.

For a large project, the number will depend on its geological features and variation of strata. Generally a grid of 50 m spacing should be used with a combination of bore holes and sounding tests.

Depth of Investigation

The depth of investigation depends on the size and type of proposed structure **Sequence of proposed strata**.

The depths of boreholes should cover the zone of soil that will be affected by the structural loads. There is no fixed rule to follow. In most cases, the depths of boreholes are governed by experience based on the geological character of the ground, the importance of the structure, the structural loads, and the availability of equipment

Guidelines for depth of investigation:

At least one boring should be taken to deeper stratum, probably up to the bedrock if practicable.

Borings should penetrate at least 3 m into rock.

Other borings may be taken at least to significant stress level.

In compressible soils such as clays, the borings should penetrate at least between 1 and 3 times the width of the proposed foundation or until the stress increment due to the heaviest foundation load is less than 10%, whichever is greater.

$$(W + eSch2 P)/((W + P))$$

In very stiff clays, borings should penetrate 5-7 m to prove that the thickness of the stratum is adequate.

Borings must penetrate below any fills or very soft deposits below the proposed structure.

The minimum depth of boreholes should be 6 m unless bedrock or very dense material is encountered.

Significant depth The investigation shall be carried out to the point at which the vertical stress due to proposed structure is equal to or less than 10% of original effective stress at the point before the structure is constructed – significant depth

Methods of borings i) Auger boring – preferred for shallow depths, low ground water table

Wash boring: high water table, deeper soil deposit iii) Rotary drilling: high quality boring, also for rock drilling iv)

Percussion drilling: fast drilling, not taking samples, gravel

Auger boring:- Augers are used in cohesive and other soft soils above water table. They may either be operated manually or mechanically. Hand augers are used up to a depth up to 6 m. Mechanically operated augers are used for greater depths and they can also be used in gravelly soils. Augers are of two types: (a) spiral auger and (b) post-hole auger.

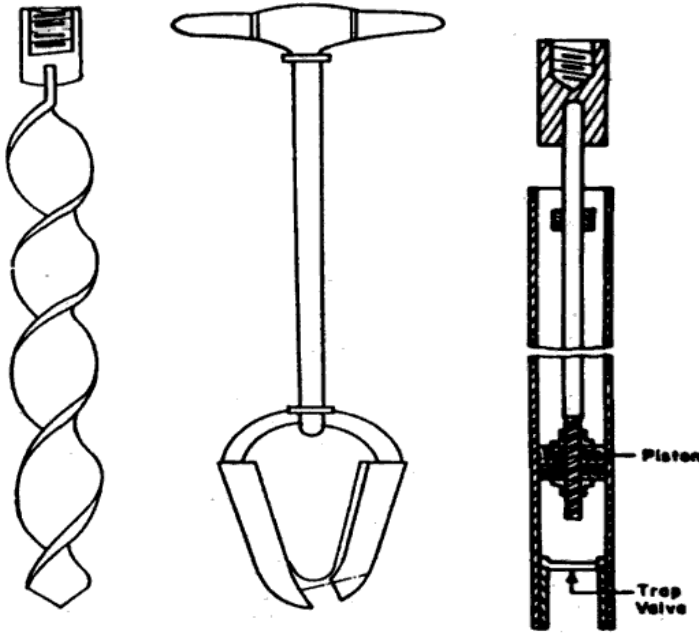

(a) HELICAL AUGER (b) POST-HOLE AUGER.

Hand Augers Sand pump

Samples recovered from the soil brought up by the augers are badly disturbed and are useful for identification purposes only. Auger boring is fairly satisfactory bore explorations at shallow depths and for exploratory borrow pits.

Auger and shell boring:- cylindrical augers and shells with cutting edge or teeth at lower end can be used for making deep borings. Hand operated rigs are used for depths up to 25 m and mechanized rigs up to 50 m. Augers are suitable for soft to stiff clays, shells for very stiff and hard clays, and shells or sand pumps for sandy soils. Small boulders, thin soft strata or rock or cemented gravel can be broken by chisel bits attached to drill rods. The hole usually requires a casing.

Wash boring:-Wash boring is a fast and simple method for advancing holes in all types of soils. Boulders and rock cannot be penetrated by this method. The method consists of first driving a casing through which a hollow drilled rod with a sharp chisel or chopping bit at the lower end is inserted. Water is forced under pressure through the drill rod which is alternatively raised and dropped, and also rotated. The resulting chopping and jetting action of the bit and water disintegrates the soil. The cuttings are forced up to the ground surface in the form of soil-water

slurry through the annular space between the drill rod and the casing. The change in soil

$$(W + eSch2 P)/((W + P))$$

stratification could be guessed from the rate of progress and colour of wash water. The samples recovered from the wash water are almost valueless for interpreting the correct geo-technical properties of soil.

Percussion drilling:-In this method, soil and rock formations are broken by repeated blows of heavy chisel or bit suspended by a cable or drill rod. Water is added to the hole during boring, if not already present and the slurry of pulverised material is bailed out at intervals. The method is suitable for advancing a hole in all types of soils, boulders and rock. The formations, however, get disturbed by the impact.

Rotary boring:- Rotary boring or rotary drilling is a very fast method of advancing hole in both rocks and soils. A drill bit, fixed to the lower end of the drill rods, is rotated by a suitable chuck, and is always kept in firm contact with the bottom of the hole. A drilling mud, usually a water solution of bentonite, with or without other admixtures, is continuously forced down to the hollow drill rods. The mud returning upwards brings the cuttings to the surface. The method is also known as mud rotary drilling and the hole usually requires no casing.

Rotary core barrels, provided with commercial diamond-studded bits or a steel bit with shots, are also used for rotary drilling and simultaneously obtaining the rock cores or samples. The method is then also known as core boring or core drilling. Water is circulated down drill rods during boring.

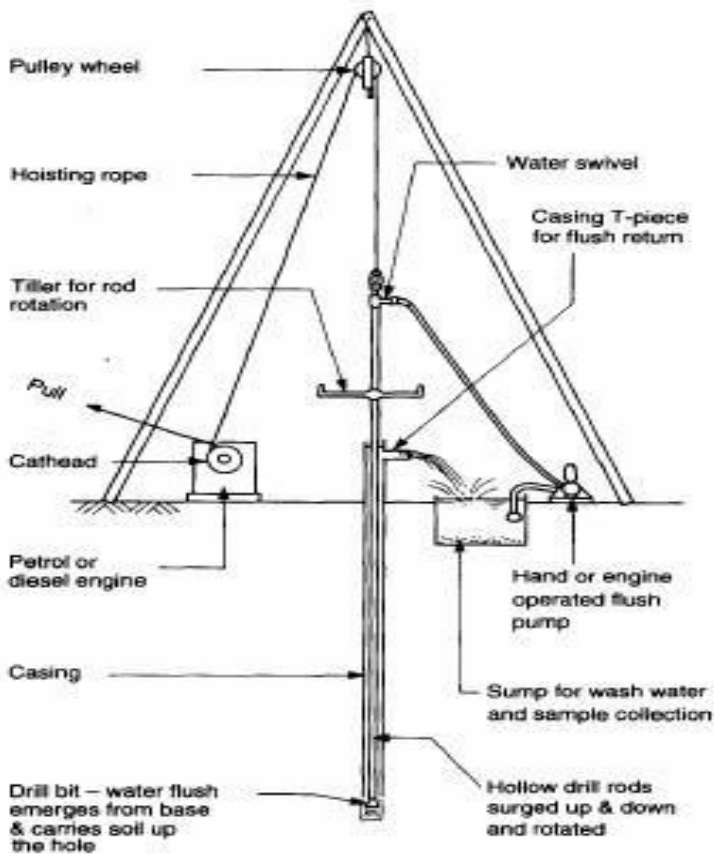

Wash boring

Soil Samples and samplers.

Types of Samples

Samples of soil taken out of natural deposits for testing may be classified as:

Disturbed sample

Undisturbed sample

A disturbed sample is that in which the natural structure of the soil gets modified partly or fully during sampling and an undisturbed sample is that in which the natural structure and other physical properties remain preserved.

Disturbed but representative samples can generally be used for v Grain-size analysis v Determination of liquid and plastic limits, Specific gravity of soil solids, Organic content determination and Soil classification

$$(W + eSch2 P)/((W + P))$$

Undisturbed samples must be used for -- Consolidation test, Hydraulic conductivity test and Shear strength test

There is an increasing variety of plant, sampling methods and tools, with particular advantages incost, quality of sampling, speed of operation, use in conditions of limited access or headroom, etc., and the choice of rig is affected by the likely soil conditions to be encountered. **Spacing of Borings**

Type of project Spacing (m)

Multistory buildings 10 – 30

One-story industrial plants 20 – 60

Highways 250 – 500

Residential subdivision 250 – 500

Dams and dikes 40 – 80

Soil Sampling

Need for sampling: -Sampling is carried out in order that soil and rock description, and laboratory testing can be carried out.

Laboratory tests typically consist of:

Index tests (for example, specific gravity, water content)

Classification of tests (for example, Atterberg limit tests on clays); and

Tests to determine compressibility, and permeability.

Factors to be considered while sampling soil

Samples should be representative of the ground from which they are taken.

ii) They should be large enough to avoid fissuring and fracturing.

iii) They should be taken in such a way that they have not lost fractions of the situ soil (for compressibility disturbance as possible).

Type of soil samples

Non-Representative samples:-Non-Representative soil samples are those in which neither the in-situ soil structure, moisture content nor the soil particles are preserved.

They are not representative

They cannot be used for any tests as the soil particles either gets mixed up or some particles may be lost.

e.g., Samples that are obtained through wash boring or percussion drilling.

Disturbed soil samples:- Disturbed soil samples are those in which the in-situ soil structure and moisture content are lost, but the soil particles are intact.

They are representative

They can be used for grain size analysis, liquid and plastic limit, specific gravity, compaction tests, moisture content, organic content determination and soil classification test performed in the lab

e.g., obtained through cuttings while auguring, grab, split spoon (SPT), etc.

Undisturbed soil samples:-Undisturbed soil samples are those in which the in-situ soil structure and moisture content are preserved.

They are representative and also intact

These are used for consolidation, permeability or shear strengths test (Engineering properties) • More complex jobs or where clay exist

In sand is very difficult to obtain undisturbed sample

Obtained by using Shelby tube (thin wall), piston sampler, surface (box), vacuum, freezing, etc.,

Design Features affecting the sample disturbance

Area ratio

Inside Clearance

Outside Clearance

$$\frac{W + eSch^2 P}{(W + P)}$$

Recovery Ratio

$$(W + eSch2 P)/((W + P))$$

Inside wall friction

Design of non-return valve

Method of applying force

sizes of sampling tubes

Inside clearance ratio $C_i = \frac{D_s - D_c}{D_s} \times 100\%$

D_c

The soil is under great stress as it enters the sampler and has a tendency to laterally expand.

The inside clearance should be large enough to allow a part of lateral expansion to take place, but it should not be so large that it permits excessive deformations and causes disturbances of the sample.

For good sampling process, the inside clearance ratio should be within 0.5 to 3 %.

For sands silts and clays, the ratio should be 0.5 % and for stiff and hard clays (below water table), it should be 1.5 %.

For stiff expansive type of clays, it should be 3.0 %.

D^2

Area ratio $A_r = \frac{D - D_c}{D} \times 100\%$

c

Outside clearance ratio $C_o = \frac{D_w - D_r}{D_w} \times 100\%$

For good sampling process, the ratio should be within 0-2 %. Minimum inside diameter = 75mm.

The length (L) should be at least equal to (the intended length + 100mm) for residual soils.

The tube should be uniform and should not have any protrusions or irregularities. The inside of the tube should be clean and smooth.

Recovery ratio $R = \frac{L}{(W + e) \frac{Sch}{2P} + (W + P)} \times 100$

Where, L is the length of the sample within the tube, H is the depth of penetration of the sampling tube. It represents the disturbance of the soil sample. For good sampling the recovery ratio should be 96 to 98 %. Wall friction can be reduced by suitable inside clearance, smooth finish and oiling. The non-return valve should have large orifice to allow air and water to escape

Inside wall friction

The friction on the inside wall of the sampling tube causes disturbances of the sample.

Therefore the inside surface of the sampler should be as smooth as possible.

It is usually smeared with oil before use to reduce friction.

Design of non-return valve

The non – return valve provided on the sampler should be of proper design.

It should have an orifice of large area to allow air, water or slurry to escape quickly when the sampler is driven.

It should close when the sample is withdrawn.

Method of applying force

The degree of disturbance depends upon the method of applying force during sampling and depends upon the rate of penetration of the sample.

For obtaining undisturbed samples, the sampler should be pushed and not driven

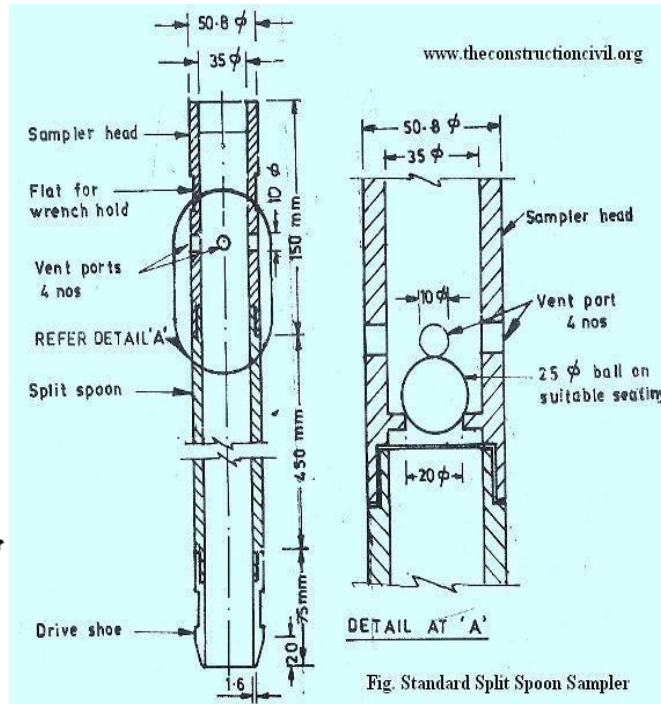
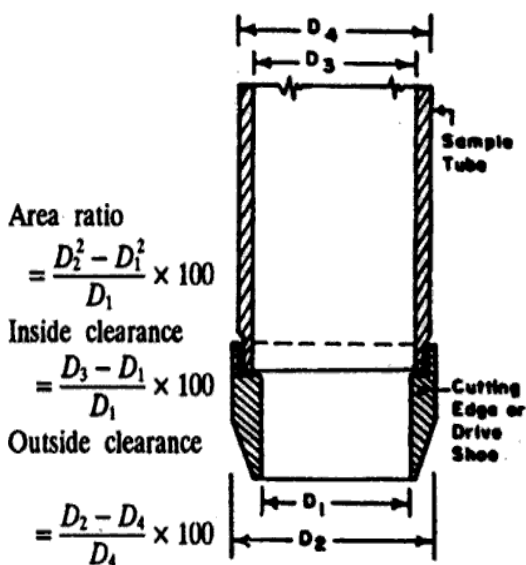

Penetration Tests

These tests involve the measurement of the resistance to penetration of a sampling spoon, a cone or other shaped tools under dynamic or static loadings. The resistance is empirically correlated with some of the engineering properties of soil as density index, consistency, bearing capacity, etc., These tests are useful for general exploration of erratic soil profiles, for finding depth to bedrock or hard stratum, and to have an approximate indication of the strength and other properties of soils, particularly the cohesionless soils, from which it is difficult to obtain undisturbed samples. The two commonly used tests are the standard penetration test and the cone penetration test.

Standard Penetration Test

Test is performed in a clean hole, 55 O_D to 150 I_Dmm in diameter

A thick all split tube sampler, 50.8 mm and 35 mm is driven into the undistributed soil at the bottom of the hole

A 65kg drive weight with 75cm free fall is used to drive the sampler

The sampler is first driven through 15cm as a seating drive

It is further driven through 3cm

The number of blows required to drive the sampler 30cm beyond the seating drive is termed as penetration resistance N.

In very fine silty saturated sand an apparent increase in resistance occurs

For overburden pressure on the value of N(Terzaghi and Peck) $N_o = 15 + \frac{1}{2} (N-15)$

For air-dry or moist sand, $N_o = N \frac{1.42\sigma' + 10}{50}$

Where, $N_e =$ corrected value for overburden effect
 $N =$ actual value of blows

$\sigma' =$ effective overburden pressure in t/m^2 (not to exceed $28.2 t/m^2$)
Meyerhoff $\phi = 25 + 0.15 I_D$ fines greater than 5 %

$\phi = 20 + 0.15 I_D$ fines less than 5 %

Dutch Cone Test

Test is used for getting a continuous record of the resistance of soil by penetrating steadily under static pressure

A cone with a base of $10cm^2$ and an angle of 60° at the vertex

The cone is carried at the lower end of a steel driving rod

To know the cone resistance, the cone alone is first forced down upto 8cm and resistance is recorded

The steel tube is then pushed down upto the cone, and both together are further penetrated upto 20cm

Cone test is useful in determining the bearing capacity of pits in cohesionless soils, particularly fine sands

The cone resistance (kg/cm^2) is approximately equal to 10 times the penetration resistance N

Soil investigation is required for the following purposes –

To know the allowable bearing capacity of foundation for proposed building.

To know the depth and type of foundation for the proposed building.

To know the allowable passive resistance for the foundation of proposed building.

To know the type, grading and nature of soil.

To know the ground water level.

Methods of soil investigation

The common methods of soil investigation are –

Inspection

Test pits

Probing, and

Boring.

Inspection: In some places you don't have to investigate much. You'll get enough data to design the foundation of the proposed building by just inspecting the plot. This method of soil investigation includes know the geological condition of the plot, getting data about neighbor buildings, their foundation type and depth, etc.

Test pits: This is done to collect soil samples for detail analysis. In this method several pits are dug by hand or excavator. The depth of pit is below 5 feet so that one can have visual inspection. Several samples are collected from the pit of both disturbed and undisturbed soil.

Probing: In this method a 25 mm or 40 mm diameter steel bar is driven into the ground till solid soil strata is found. It is normally driven by hammer. The penetration and withdrawal of the steel rod is closely observed to know the nature of soil layer.

Boring: In this method several bore holes are made for the purpose of collecting soil sample from below the ground. Then the collected sample is analyzed for preparing the soil report

Typical steps of soil investigation

Soil investigation involves following steps -

Details planning for the sequence of operations

Collecting the samples of soil from the plot.

Determining the soil characteristics by conducting field tests.

Study the condition of ground water level.

Collecting ground water sample for chemical analysis.

Soil exploration.

Testing all collected samples in the laboratory.

Analysis the test results.

Preparing report.

A recommended procedure is as follows:

Collect data, categorize it and rough out a preliminary draft.

Edit the draft and seek methods of visual presentation and tabulation.

Polish re-draft and check for improvements in presentation check for typing errors and appearance.

Factors affecting quality of report.

There are other factors which can affect the quality of the investigation, recommendations and the engineering judgment. Among those which may affect some engineers are:

Uncritical acceptance of well-presented opinion, results of sophisticated (but not necessarily relevant) tests and over- and unqualified respect for some specialists.

Allowing site difficulties to dictate the investigation in an attempt to keep the investigation simple and cheap.

$(W + eSch2 P)/((W + P))$

Lack of recognition that piling and other foundation techniques can be used to economic advantage even on good sites.

Lack of recognition that some fills, possibly upgraded by ground improvement techniques, can provide an adequate and economic bearing strata.

Lack of appreciation that advances in structural design can accommodate relatively high settlements.

Under-estimation of the importance of the designer, at least, visiting the site during the investigation or dismissal of trial pits as unscientific or out-dated.

Sequence of report

Foundation reports follow the normal sequence of items of engineering reports in having a title, contents list, and synopsis, and introduction, body of the report, conclusions and recommendations. Lengthy descriptions of tests and similar matters are best dealt with in appendices and the test results tabulated in the body of the report. The client tends to read the synopsis and recommendations; the main and sub-contractors concentrate on the body of the report and the design office on its conclusions and recommendations.

Site description

This, as far as possible, should be given on small-scale plans showing site location, access and surrounding area. The proposed position of the buildings and access roads should be shown. The site plan should also show the general layout and surface features, note presence of existing buildings, old foundations and previous usage, services, vegetation, surface water, any subsidence or unstable slopes, etc.

Written description of the site exposure (for wind speed regulations) should be given together with records of any flooding, erosion and other geographical and hydrographic information.

Geological maps and sections should, when they are necessary, be provided, noting mines, shafts, quarries, swallow holes and other geological features affecting design and construction.

Photographs taken on the site, preferably color ones, can be very helpful and should be supplemented by aerial photographs if considered necessary.

The ground investigation

Background study and location of holes. This should give a full account of the desk-top study, examination of old records, information from local authorities, public utilities and the like, and the field survey. It should detail the position and depth of trial pits and boreholes, equipment used and in situ testing and information.

Boreholes, trial pits and soil profiles. This section will be mainly a visual presentation of the logs and profiles together with colour photographs of the trial pits. Where possible, written information should be given in note form on the soil profiles.

Soil tests. This should list the site and laboratory tests drawing attention to any unusual, unexpected or special results. The results of the tests should be tabulated, for ease of reference, and diagrams of such information as particle size distribution, pressure-void ratio curves and Mohr's circles should be given.

Results

This must give details of ground conditions, previous use of site, present conditions, groundwater and drainage pattern

The tests must give adequate information to determine the soil's bearing capacity, settlement characteristics, behavior during and after foundation construction and, where necessary, its chemical make-up and condition

Recommendations This is both comment on the facts and also opinions based on experience; the difference should be made clear. Since the discussion is usually a major part of the report it should be broken down into sections for ease of reference and readability. The final section should give firm recommendations on the foundation type or types to be adopted

Objectives of Site Investigation

To access the general suitability of the site.

To achieve safe and economical design of foundations and temporary works.

To know the nature of each stratum and engineering properties of the soil and rock, which may affect the design and mode of construction of proposed structure and foundation.

To foresee and provide against difficulties that may arise during construction due to ground and other local conditions.

To find out the sources of construction material and selection of sites for disposal of water or surplus material.

To investigate the occurrence or causes of all natural and man made changes in conditions and the results arising from such changes.

To ensure the safety of surrounding existing structures.

To design for the failed structures or remedial measures for the structures deemed to be unsafe.

To locate the ground water level and possible corrosive effect of soil and water on foundation material.

Methods of site exploration

The various types of site investigation are:

Open excavation, Boring, Subsurface Sounding and Geophysical Methods

Geophysical exploration may be used with advantage to locate boundaries between different elements of the subsoil as these procedures are based on the fact that the gravitational, magnetic, electrical, radioactive or elastic properties of the different elements of the subsoil may be different. Differences in the gravitational, magnetic and radioactive properties of deposits near the surface of the earth are seldom large enough to permit the use of these properties in exploration work for civil engineering projects. However, the resistivity method based on the electrical properties and the seismic refraction methods based on the elastic properties of the deposits have been used widely in large civil engineering projects. Different methods of geophysical explorations

Electrical resistivity method

Electrical resistivity method is based on the difference in the electrical conductivity or the electrical resistivity of different soils. Resistivity is defined as resistance in ohms between the opposite phases of a unit cube of a material.

$$\rho = \frac{RA}{L}$$

ρ is resistivity in ohm-cm, R is resistance in ohms, A is the cross sectional area (cm²), L is length of the conductor (cm).

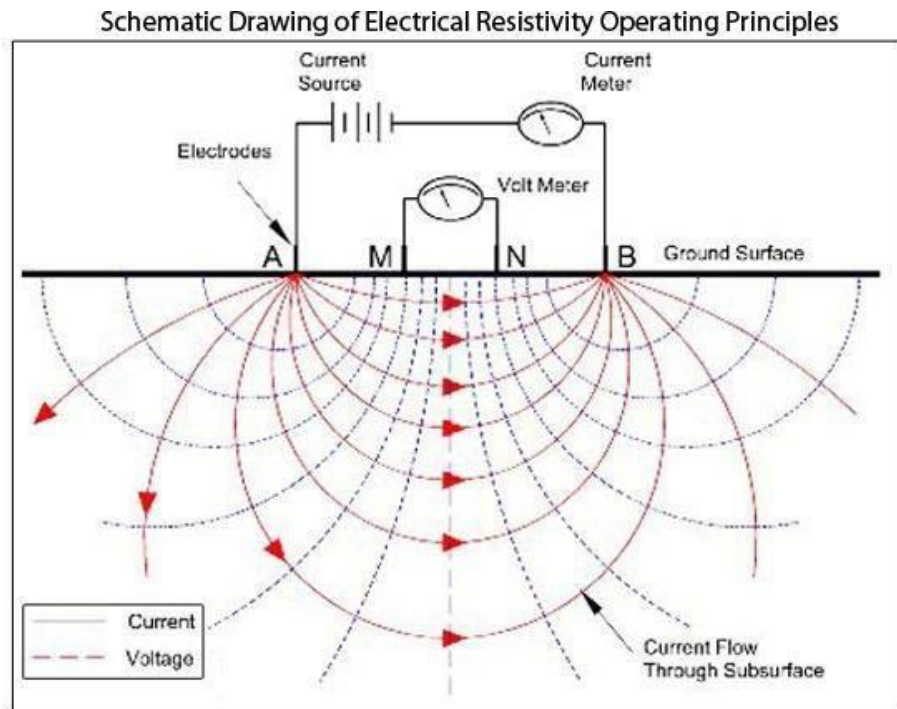

Applications of resistivity soundings are:

Characterize subsurface hydrogeology, Determine depth to bedrock/overburden thickness, Determine depth to groundwater, Map stratigraphy, clay aquitards, salt-water intrusion and vertical extent of certain types of soil and groundwater contamination .Estimate landfill thickness

Resistivity profiling is used to:

Map faults, Map lateral extent of conductive contaminant plumes, Locate voids, Map heavy metals soil contamination ,Delineate disposal areas ,Map paleochannels, Explore for sand and gravel ,Map archaeological sites

Seismic Method

Seismic refraction is a geophysical method used for investigating subsurface ground conditions utilizing surface-sourced seismic waves. The methods depend on the fact that seismic waves have differing velocities in different types of soil (or rock): in addition, the waves are refracted when they cross the boundary between different types (or conditions) of soil or rock. The methods enable the general soil types and the approximate depth to strata boundaries, or to bedrock, to be determined.

Operation

Pulses of low frequency seismic energy are emitted by a seismic source such as a hammer-plate, weight drop or buffalo gun. The type of source is dependent on local ground conditions and required depth penetration. Explosives are best for deeper applications but are constrained by environmental regulations.

The seismic waves propagate downward through the ground until they are reflected or refracted off subsurface layers. Refracted waves are detected by arrays of 24 or 48 geophones spaced at regular intervals of 1 - 10 metres, depending on the desired depth penetration of the survey. Sources are positioned at each end of the geophone array to produce forward and reverse wave arrivals along the array. Additional sources may be used at intermediate or off-line positions for full coverage at all geophone positions.

A **geophone** is a device that converts ground movement (velocity) into voltage, which may be recorded at a recording station. The deviation of this measured voltage from the base line is called the seismic response and is analyzed for structure of the earth.

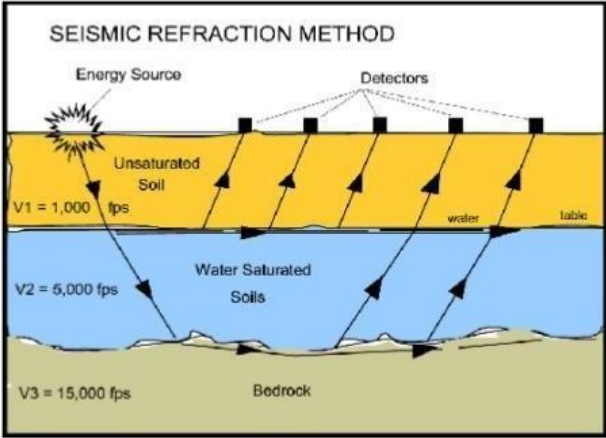
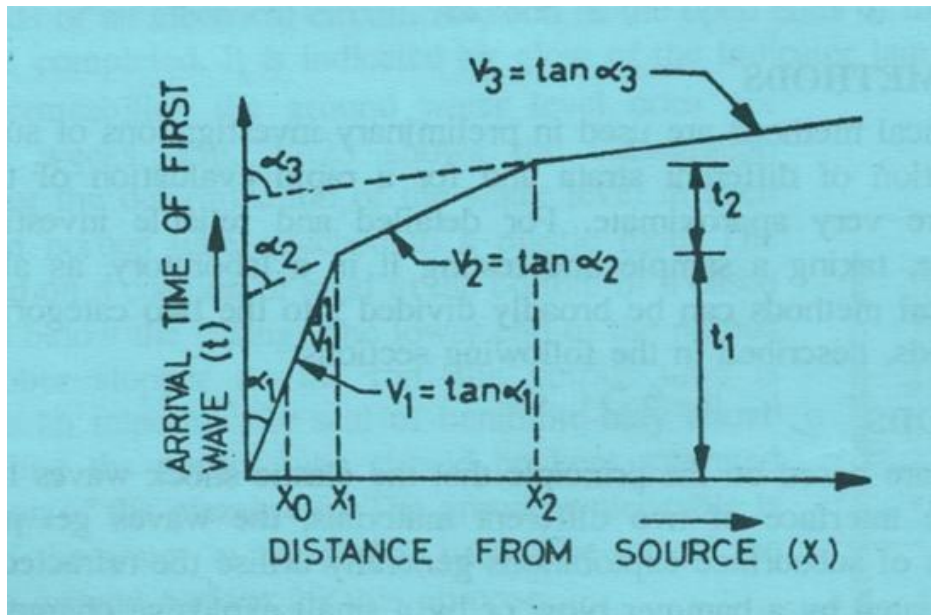
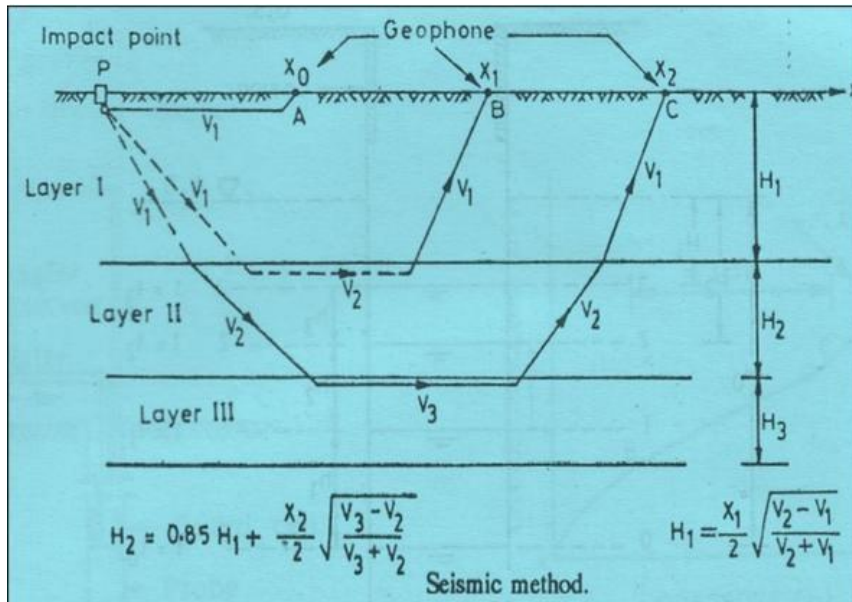

Fig. seismic refraction method



APPLICATIONS

Measures Bedrock Depth & Overburden Thickness

Determines Rip ability Parameters

Investigates Pipeline Routes

Locates Geological Structures

$(W + eSch2 P)/(W + P)$

Evaluates Sand & Gravel Deposits

Defines Ancient Landfill Sites

Boring Log

During soil exploration all suitable details are recorded and presented in a boring log. Additional information consisting mainly of lab and field test result is added to complete the boring log.

Details of Boring Log

The ground conditions discovered in each borehole are summarised in the form of a bore log. The method of investigation and details of the equipment used should be stated on each log. The location, ground level and diameter of the hole should be specified. The names of the client and the project should be mentioned.

Other Details of Boring Log

The soil profile with elevations of different strata.

Ground water level.

Termination level of the bore hole.

The depth at which samples were taken or at which in-situ tests were performed.

The type of soil samples.

N-values at the measured elevation.

The results of important laboratory tests

Soil Exploration Report

At the end of the soil exploration program, the soil and rock samples, collected from the field are subjected to visual observation and laboratory tests. Then, a soil exploration report is prepared for use by the planning and design office. Any soil exploration report should contain the following information:

Scope of investigation

General description of the proposed structure for which the exploration has been conducted

Geological conditions of the site

Drainage facilities at the site

Details of boring

$$(W + eSch2 P)/((W + P))$$

Description of subsoil conditions as determined from the soil and rock samples collected

Ground water table as observed from the boreholes

Details of foundation recommendations and alternatives

Any anticipated construction problems

Limitations of the investigation

The following graphic presentations also need to be attached to the soil exploration report:

Site location map

Location of borings with respect to the proposed structure

Boring logs

Laboratory test results

Other special presentations

The boring log is the graphic representation of the details gathered from each bore hole

$$(W + eSch2 P)/((W + P))$$