

**LECTURE NOTES**  
**ON**  
**BASIC MANUFACTURING PROCESS**  
**5<sup>th</sup> SEMESTER**  
**Dr. SISIRA KANTA PATTNAIK**  
**ASST. PROFESSOR**  
**DEPARTMENT OF MECHANICAL ENGINEERING**



**GANDHI INSTITUTE OF TECHNOLOGY AND MANAGEMENT(GITAM)**

**Affiliated to BPUT & SCTE&VT, Govt. of Odisha**

**Approved by AICTE, New Delhi**



## Syllabus

### PCME4206 **Basic Manufacturing Process**

#### **Module - I (12 Lectures)**

##### 1. Foundry :

- (a) Types of patterns, pattern materials and pattern allowances.
- (b) Molding Materials - sand molding, metal molding, investment molding, shell molding.
- (c) Composition of molding sand, Silica sand, Zircon sand, binders, additives, Binders - clay, binders for CO<sub>2</sub> sand, binder for shell molding, binders for core sand.
- (d) Properties of molding sand and sand testing.
- (e) Melting furnaces - cupola, resistance furnace, induction and arc furnace.
- (f) Solidification of castings, design of risers and runners, feeding distance, centre line freezing resistance chills and chaplets.
- (g) Degasification and inoculation of metals.
- (h) Casting methods like continuous casting, centrifugal casting, disc casting.
- (i) Casting defects.

#### **Module – II (12 Lectures)**

2. Welding and cutting: Introduction to gas welding, cutting, Arc welding and equipment's. TIG (GTAW) and MIG (GMAW) welding, resistance welding and Thermit welding. Weldability  
Modern Welding methods like plasma Arc, Laser Beam, Electron Beam, Ultrasonic, Explosive and friction Welding, edge preparation in butt welding.  
Brazing and soldering, welding defects.  
Destructive and non-destructive testing of castings and welding.
3. Brief introduction to powder metallurgy processes.

#### **Module – III (14 Lectures)**

4. Plastic deformation of metals: Variables in metal forming and their optimization. Dependence of stress strain diagram on Strain rate and temperature. Hot and cold working of metals, classification of metal forming processes.
5. Rolling: Pressure and Forces in rolling, types of rolling mills, Rolling defects.
6. Forging: Smith Forging, Drop and Press forging, M/c forging, Forging defects.
7. Extrusions: Direct, Indirect, Impact and Hydrostatic extrusion and their applications, Extrusion of tubes.
8. Wire drawing methods and variables in wire-drawing, Optimum dies shape for extrusion and drawing.
9. Brief introduction to sheet metal working: Bending, Forming and Deep drawing, shearing.
10. Brief introduction to explosive forming, coating and deposition methods.

#### **Text Books**

1. Manufacturing technology - by P.N.Rao, Tata McGraw Hill publication.
2. Welding Technology by R.A. Little, TMH
3. Manufacturing Science by A.Ghosh and A K Malick, EWP

#### **Reference Books**

1. Fundamentals of metal casting technology by P.C. Mukherjee, Oxford PIBI.
2. Mechanical Metallurgy by Dieter, Mc-Graw Hill
3. Processes and Materials of Manufacture by R.A Lindberg, Prentice hall (India)
4. A Text Book of Production Engineering by P.C.Sharma, S.Chand

## **Module: I (Foundry)**

There are four basic manufacturing processes for producing desired shape of a product. These are casting, machining, joining (welding, mechanical fasteners, epoxy, etc.), and deformation processes.

- Casting process exploit the fluidity of a metal in liquid state as it takes shape and solidifies in a mould. It's the primary manufacturing process.
- Machining processes provide desired shape with good accuracy and precision but tend to waste material in the generation of removed portions.
- Joining processes permit complex shapes to be constructed from simpler components and have a wide domain of applications.
- Deformation processes exploit a remarkable property of metals, which is their ability to flow plastically in the solid state without deterioration of their properties. With the application of suitable pressures, the material is moved to obtain the desired shape with almost no wastage. The required pressures are generally high and the tools and equipment needed are quite expensive. Large production quantities are often necessary to justify the process.

### **Metal Casting Process:**

Casting is one of the oldest manufacturing process. It is the first step in making most of the products for which it's called basic manufacturing process.

### **Steps to be followed for a casting operation:**

- a) Making mould cavity
- b) Liquefy or melt the material by properly heating it in a suitable furnace.

- c) Liquid or molten metal is poured into a prepared mould cavity
- d) allowed to solidify
- e) product is taken out of the mould cavity, trimmed and made to shape

**More attention should be given on the following for successful casting operation:**

(i)Preparation of moulds of patterns (ii)Melting and pouring of the liquefied metal (iii)Solidification and further cooling to room temperature (iv) Defects and inspection

**Advantages of casting process:**

- Molten material can flow into very small sections so that intricate shapes can be made by this process. As a result, many other operations, such as machining, forging, and welding, can be minimized.
- Possible to cast both ferrous and non ferrous materials
- Tools are very simple and expensive
- Useful for small lot production
- Weight reduction in design
- No directional property
- There are certain parts (like turbine blades) made from metals and alloys that can only be processed this way. Turbine blades: Fully casting + last machining.
- Size and weight of the product is not a limitation for the casting process.

**Limitations:-**

- Accuracy and surface finish are not very good for final application
- Difficult to remove defects due to presence of moisture
- Metal casting is a labour intensive process
- Automation: a question

**Application:-**

Cylindrical bocks, wheels, housings, pipes, bells, pistons, piston rings, machine tool beds etc.

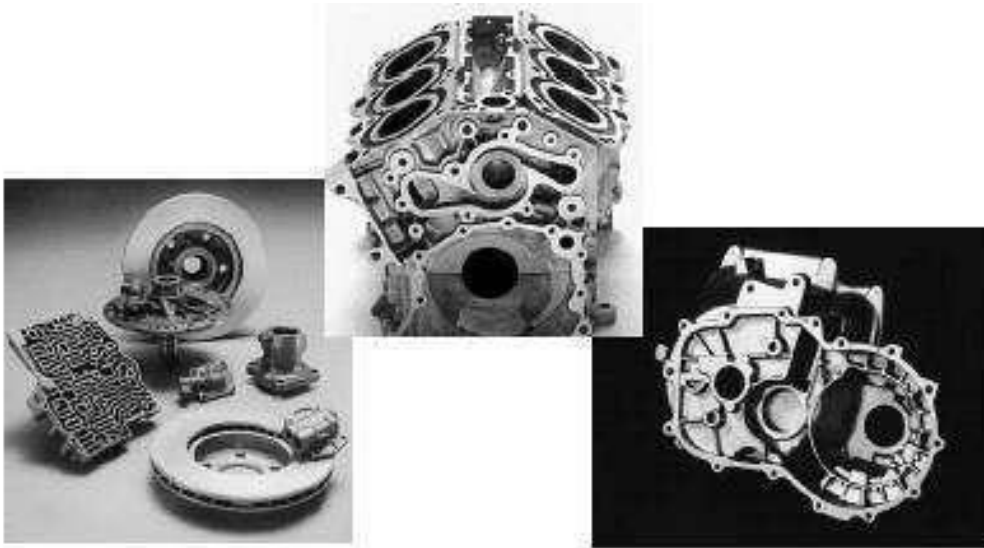

**Typical sand mould**

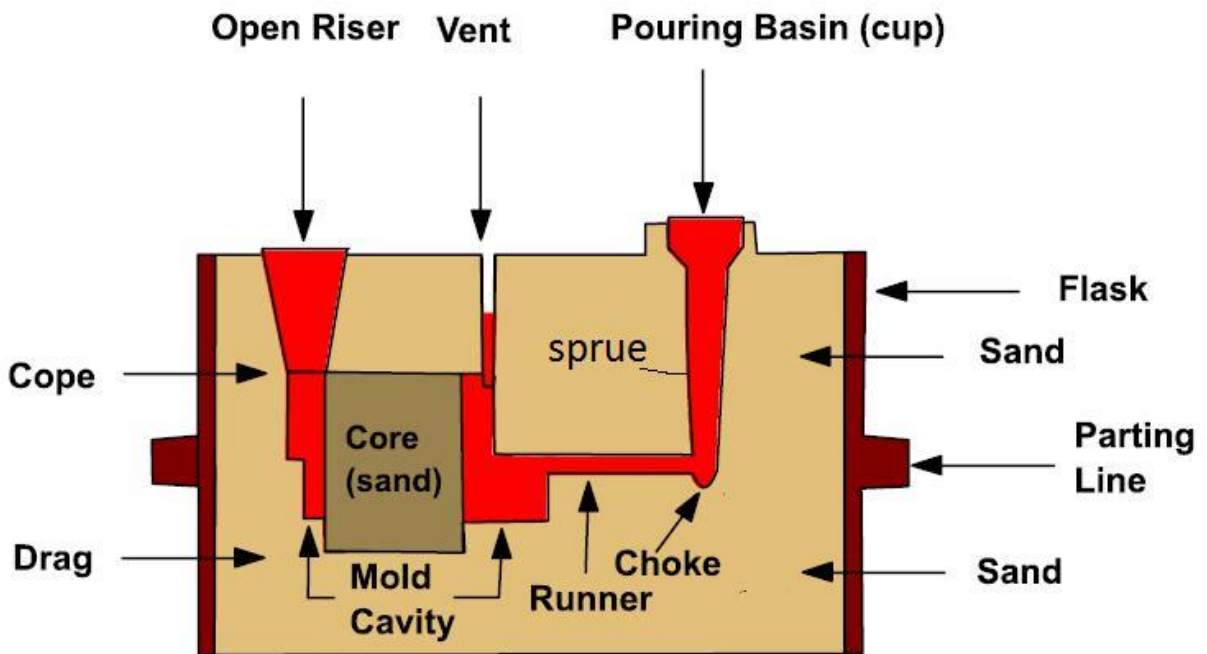

Mould Section and casting nomenclature

## Important casting terms

**Flask:** A metal or wood frame, without fixed top or bottom, in which the mould is formed. Depending upon the position of the flask in the moulding structure, it is referred to by various names such as: drag – lower moulding flask,

cope – upper moulding flask,

cheek – intermediate moulding flask used in three piece moulding.

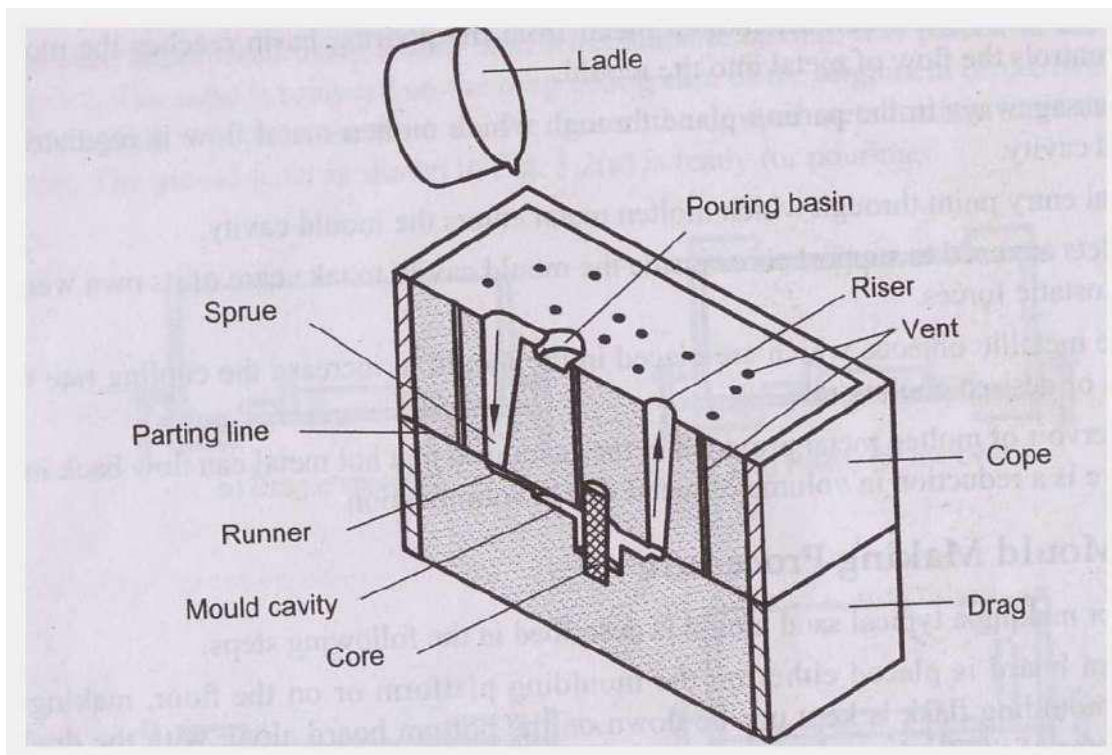

**Sand mould ready for pouring**

**Pattern:** It is the replica of the final object to be made. The mould cavity is made with the help of pattern.

**Parting line:** This is the dividing line between the two moulding flasks that makes up the mould.

**Moulding sand:** Sand, which binds strongly without losing its permeability to air or gases. It is a mixture of silica sand, clay, and moisture in appropriate proportions.

**Facing sand:** The small amount of carbonaceous material sprinkled on the inner surface of the mould cavity to give a better surface finish to the castings.

**Bottom board** – Board used to start mould making (wood)

**Backing sand** – used and burnt sand

**Core:** A separate part of the mould, made of sand and generally baked, which is used to create openings and various shaped cavities in the castings.

**Pouring basin:** A small funnel shaped cavity at the top of the mould into which the molten metal is poured.

**Sprue:** The passage through which the molten metal, from the pouring basin, reaches the mould cavity. In many cases it controls the flow of metal into the mould.

**Runner:** The channel through which the molten metal is carried from the sprue to the gate.

**Gate:** A channel through which the molten metal enters the mould cavity.

**Chaplets:** Chaplets are used to support the cores inside the mould cavity to take care of its own weight and overcome the metallostatic force.

**Riser:** A column of molten metal placed in the mould to feed the castings as it shrinks and solidifies. Also known as “feed head”.

**Vent:** Small opening in the mould to facilitate escape of air and gases.

### Steps in making sand castings:

The basic steps in making sand castings are,

- (i) Pattern making,
- (ii) Core making,
- (iii) Moulding,
- (iv) Melting and pouring,
- (v) Cleaning

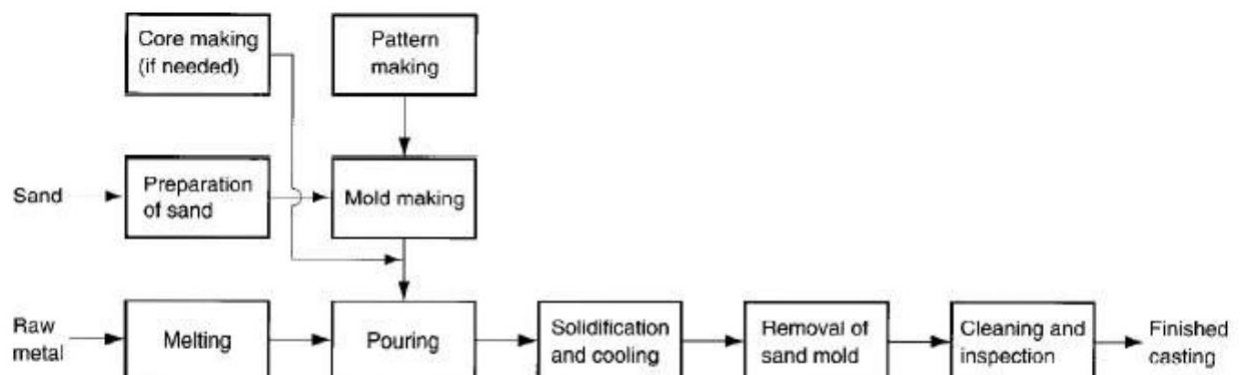

**Steps in the production sequence in sand casting**

**Pattern making** – Pattern is the replica of the part to be cast and is used to prepare the mould cavity. It is the physical model of the casting used to make the mould. Made of either wood or metal.

-The mould is made by packing some readily formed aggregate material, such as moulding sand, surrounding the pattern. When the pattern is withdrawn, its imprint provides the mould cavity. This cavity is filled with metal to become the casting.

If the casting is to be hollow, additional patterns called 'cores', are used to form these cavities.

**Pattern Materials:-** In general materials – wood, metals & plastics **Wood-**

Adv:- Easy availability, Low weight, Easily shaped, Cheap, Care to be taken

Disadv:- Moisture absorption, Distortion, Dimensional change, seasoning

Example – Pine, Teak, Deodar

**Others** – plywood boards and particle boards

Reason – Availability in various thicknesses

Higher strength

No need for seasoning

Use – Used for flat type and no three dimensional contour shapes Large scale casting

Choice of pattern materials depends on

- Size of casting
- No. of castings to be made from pattern
- Dimensional accuracy required

A pattern is always made larger than the final part to be made. The excess dimension is known as **Pattern allowance**.

Pattern allowance => shrinkage allowance, machining allowance

- **Shrinkage allowance:** It will take care of contractions of a casting which occurs as the metal cools to room temperature.



**Liquid Shrinkage:** Reduction in volume when the metal changes from liquid state to solid state. Riser which feed the liquid metal to the casting is provided in the mould to compensate for this.

**Solid Shrinkage:** Reduction in volume caused when metal loses temperature in solid state. Shrinkage allowance is provided on the patterns to account for this. Shrink rule is used to compensate solid shrinkage depending on the material contraction rate.

- Cast iron: One foot (=12 inches) on the **1/8-in-per-foot shrink rule** actually measures 12-1/8 inches.
- So, **4 inch** will be **4-1/24 inch** for considering shrinkage allowance.

#### Shrink rule for other materials

Material	Dimension	Shrinkage allowance (inch/ft)
Grey Cast Iron	Up to 2 feet	0.125
	2 feet to 4 feet	0.105
	over 4 feet	0.083
Cast Steel	Up to 2 feet	0.251
	2 feet to 6 feet	0.191
	over 6 feet	0.155
Aluminum	Up to 4 feet	0.155
	4 feet to 6 feet	0.143
	over 6 feet	0.125
Magnesium	Up to 4 feet	0.173
	Over 4 feet	0.155

The shrinkage allowance depends on the coefficient of thermal expansion of the material ( $\alpha$ ). A simple relation indicates that higher the value of  $\alpha$ , more is the shrinkage allowance.

For a dimension ' $l$ ', shrinkage allowance is  $\alpha l (\theta_f - \theta_0)$ . Here  $\theta_f$  is the freezing temperature and  $\theta_0$  is the room temperature.

**Machining allowance:** It will take care of the extra material that will be removed to obtain a finished product. In this the rough surface in the cast product will be removed. The machining allowance depends on the size of the casting, material properties, material distortion, finishing accuracy and machining method.

### **Machining allowances of various metals**

Metal	Dimension (inch)	Allowance (inch)
Cast iron	Up to 12	0.12
	12 to 20	0.20
	20 to 40	0.25
Cast steel	Up to 6	0.12
	6 to 20	0.25
	20 to 40	0.30
Non ferrous	Up to 8	0.09
	8 to 12	0.12
	12 to 40	0.16

### ***Draft –***

Vertical faces of the pattern are to be made tapered to reduce the chances of damage to the mould cavity. It varies with the complexity of the job. Inner details require more allowance than outer. This allowance is more for hand moulding than machine moulding.

### **Typical Draft Allowances**

Pattern material	Height of the given surface (inch)	<b>Draft angle (External surface)</b>	<b>Draft angle (Internal surface)</b>
Wood	1	3.00	3.00
	1 to 2	1.50	2.50
	2 to 4	1.00	1.50
	4 to 8	0.75	1.00
	8 to 32	0.50	1.00

Metal and plastic	1	1.50	3.00
	1 to 2	1.00	2.00
	2 to 4	0.75	1.00
	4 to 8	0.50	1.00
	8 to 32	0.50	0.75

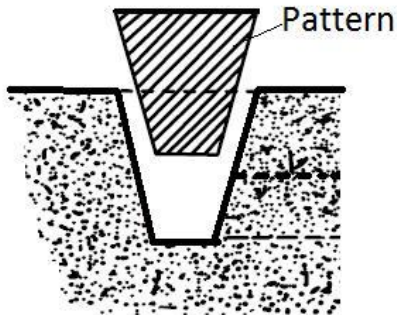

Pattern having draft allowance on vertical surfaces

***Shake allowance –***

This is a negative allowance. Applied to those dimensions which are parallel to parting plane.

***Distortion allowance –***

Metals just solidified are very weak, which may be distorted. This allowance is given to the weaker sections like long flat portion, U & V sections, complicated casing, thin & long sections connected to thick sections.

The distortion in casting may occur due to internal stresses. These internal stresses are caused on account of unequal cooling of different sections of the casting and hindered contraction.

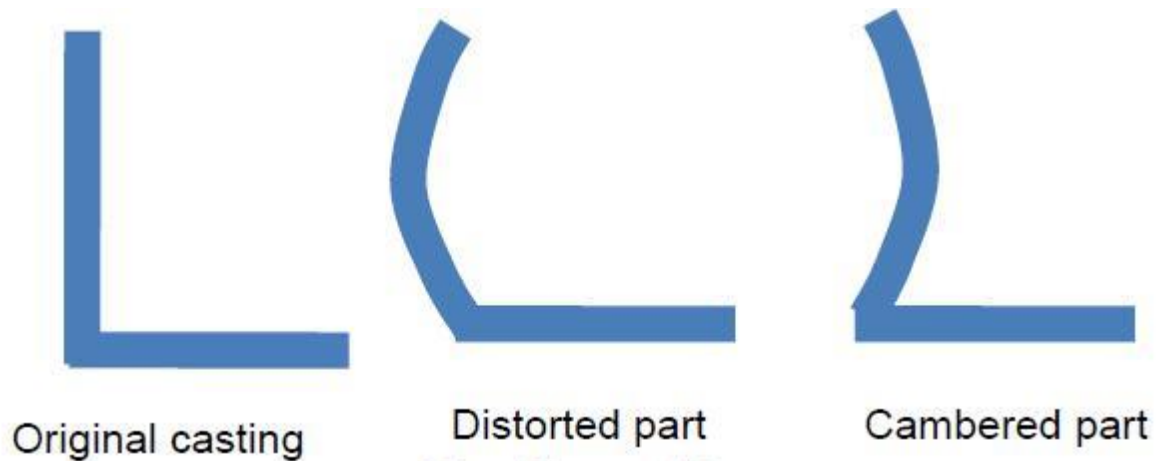

### TYPES OF PATTERNS:-

Various types of patterns depends on - Complexity of the job

- No of castings required
- Moulding procedure adopted

**(a) Single piece or solid pattern** – Inexpensive and simplest one

Single piece

Simple job

Useful for Small scale production

Pattern will be entirely in the drag

One surface is flat and at the parting line

Used for very small scale production

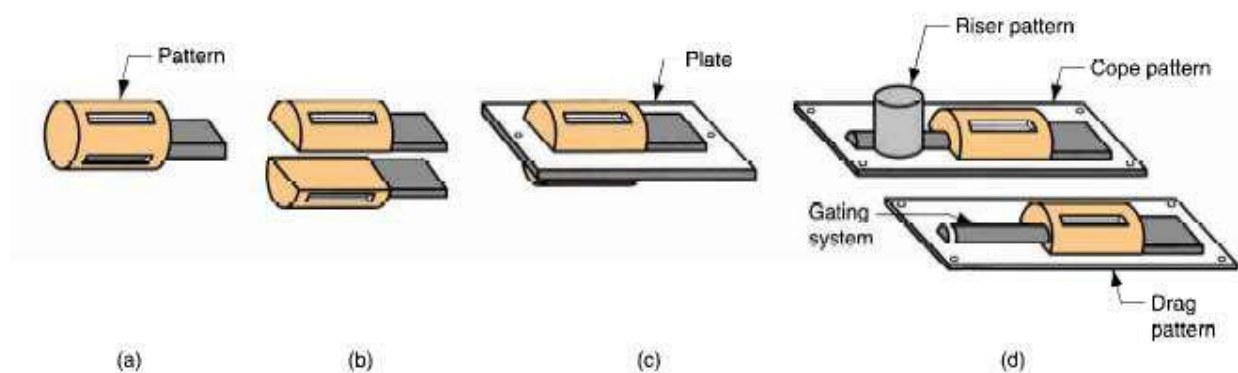

**(b) Split or two piece pattern** – Used for intricate casting

Split along the parting line

Used where depth of job is too high

Aligned with dowel pins fitted to cope

**(c) Gated pattern** – Gating and runner system are integrated with the pattern

Improves productivity

**(d) Cope and drag pattern** - Similar to split pattern

For cope and drag, separately attached gating system to metal plate

Heavy and inconvenient for handling

Useful for Continuous production

**(e) Match plate pattern** – Similar to cope and drag patterns with gating and risering system mounted on a single matching plate

Pattern and match plate are made up of metal (Al)

Useful for small casting with high dimensional

accuracy Suitable for large scale production

Gating system is attached to the match plate Expensive

**(f) Loose piece pattern** – Withdrawing of the pattern from the mould is difficult, Useful for highly skilled job, Expensive

**(g) Follow board pattern** – Used for structurally weak portions

**(h) Sweep pattern** – Useful for axi-symmetrical and prismatic shape Suitable for large scale production

**(i) Skeleton pattern** – Stripes of wood are used for building final pattern Suitable for large casting

**Core making** Cores are placed into a mould cavity to form the interior surfaces of castings. Thus the void space is filled with molten metal and eventually becomes the casting.

Core and core print: - Cores are used to make holes, recesses etc. in castings

- So where coring is required, provision should be made to support the core inside the mould cavity. Core prints are used to serve this purpose.

The core print is an added projection on the pattern and it forms a seat in the mould on which the sand core rests during pouring of the mould.

- The core print must be of adequate size and shape so that it can support the weight of the core during the casting operation.

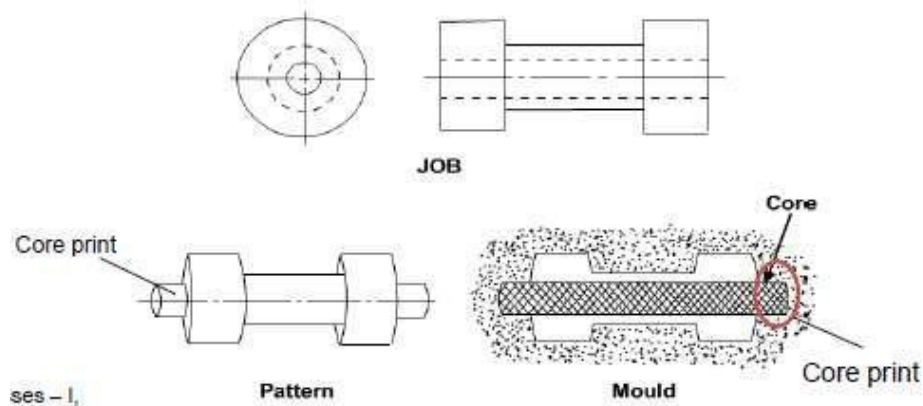

## Making a simple sand mould

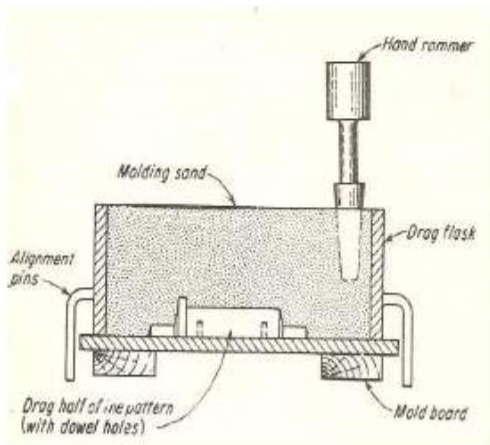

- 1) The drag flask is placed on the board
- 2) Dry facing sand is sprinkled over the board
- 3) Drag half of the pattern is located on the mould board. Dry facing sand will provide a non-sticky layer.
- 4) Molding sand is then poured in to cover the pattern with the fingers and then the drag is filled completely
- 5) Sand is then tightly packed in the drag by means of hand rammers. Peen hammers (used first close to drag pattern) and butt hammers (used for surface ramming) are used.

- 6) The ramming must be proper i.e. it must neither be too hard or soft. Too soft ramming will generate weak mould and imprint of the pattern will not be good. Too hard ramming will not allow gases/air to escape and hence bubbles are created in casting resulting in defects called 'blows'. Moreover, the making of runners and gates will be difficult.
- 7) After the ramming is finished, the excess sand is leveled/removed with a straight bar known as strike rod.

8) Vent holes are made in the drag to the full depth of the flask as well as to the pattern to facilitate the removal of gases during pouring and solidification. Done by vent rod.

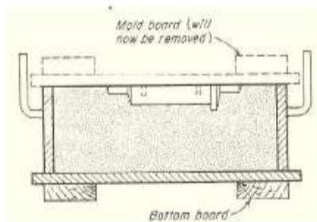

9) The finished drag flask is now made upside down exposing the pattern.

10) Cope half of the pattern is then placed on the drag pattern using locating pins. The cope flask is also located with the help of pins. The dry parting sand is sprinkled all over the drag surface and on the pattern.

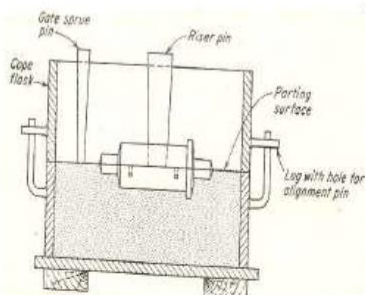

11) A sprue pin for making the sprue passage is located at some distance from the pattern edge. Riser pin is placed at an appropriate place.

12) Filling, ramming and venting of the cope is done in the same manner.

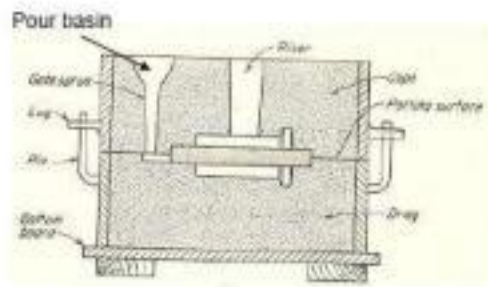

13) The sprue and riser are removed and a pouring basin is made at the top to pour the liquid metal.

14) Pattern from the cope and drag is removed.

15) Runners and gates are made by cutting the parting surface with a gate cutter. A gate cutter is a piece of sheet metal bent to the desired radius.

16) The core for making a central hole is now placed into the mould cavity in the drag. Rests in core prints.

17) Mould is now assembled and ready for pouring.

## MOULDING MATERIALS

Different types of moulding materials

are -moulding sand

-system sand (backing sand )

-rebonded sand

-facing sand

-parting sand

-core sand

Choice of moulding materials depends on processing properties. Properties\_-

1) Refractoriness- Ability to withstand high temperature of molten metal so that it does not cause fusion

Refractory materials - silica, zirconia, alumina

2) Green strength- Moulding sand containing moisture is known as green sand. The strength of the green sand is known as green strength.



3) Dry strength- When moisture is completely expelled from the moulding sand, it is known as dry sand and the strength of the sand is the dry strength.

4) Hot strength- After moisture elimination, the sand is exposed to higher temperature of molten material. Strength of sand to hold the shape of mould cavity at this higher temperature is known as hot strength.

5) Permeability – Moulding sand is porous, so it escapes gases through it. This gas evolution capability of moulding sand is known as permeability. Other properties include collapsibility, reusable, good thermal conductivity etc.

### **MOULDING SAND COMPOSITION-**

Main ingredients of moulding sand are silica grain ( $\text{SiO}_2$ ), Clay (binder) and moisture (to activate clay and provide plasticity)

**(a) Silica sand-** this is the major portion of the moulding sand. About 96% of this sand is silica grain. Rests are oxides ( $\text{Al}_2\text{O}_3$ ), sodium ( $\text{Na}_2\text{O} + \text{K}_2\text{O}$ ) and magnesium oxide ( $\text{MgO} + \text{CaO}$ ). Main source of silica sand is river sand (with /without washing). Fusion point of sand is  $14500^\circ\text{C}$  for cast iron and  $15500^\circ\text{C}$  for steels. Grain size varies from micrometer to millimetre. The shape of the grains may be round, angular, sub angular or very angular.

**(b) Zircon sand-** The main composition is zirconium silicate ( $\text{ZrSiO}_2$ ). Composition-  $\text{ZrO}_2$ - 66.25%

$\text{SiO}_2$ -30.96%

$\text{Al}_2\text{O}_3$ -1.92%

$\text{Fe}_2\text{O}_3$ -0.74%

Other - oxides

It is very expensive. In India, it is available at quilon beach, kerela. The fusion point of the sand is  $2400^\circ\text{C}$ .

Advantage - High thermal conductivity

High chilling power

High density

Requires very small amount of binder (3%)

Use - Precision steel casting

Precision investment casting

**(c) Chromite sand** – The sand is crushed from the chrome ore. The fusion point of the sand is 18000C. It requires very small amount of binder (3%).

Composition- Cr<sub>2</sub>O<sub>3</sub>- 44%

Fe<sub>2</sub>O<sub>3</sub> -28% SiO<sub>2</sub>

-2.5% CaO -0.5%

Al<sub>2</sub>O<sub>3</sub> +MgO -25%

Use – heavy steel castings Austenitic

manganese steel castings

**(d) Olivine sand**- This sand composed of the minerals of fosterite (Mg<sub>2</sub>SiO<sub>4</sub>) and fayalite (Fe<sub>2</sub>SiO<sub>4</sub>). It is versatile in nature.

### **CLAY :-**

Clay is a binding agent mixed to the moulding sand to provide strength. Popular types of clay used are kaolinite or fire clay (Al<sub>2</sub>O<sub>3</sub>.2 SiO<sub>2</sub>.2H<sub>2</sub>O) and Bentonite (Al<sub>2</sub>O<sub>3</sub>.4 SiO<sub>2</sub>.H<sub>2</sub>O nH<sub>2</sub>O). Kaolinite has a melting point from 1750 to 17870C where as Bentonite has a melting temperature range of 1250 to 13000C. Bentonite clay absorbs more water and has increased bonding power. To reduce refractoriness, extra mixtures like lime, alkalis and other oxides are added.

Bentonite is further of two types. (a) Western bentonite and (b) southern bentonite

Western bentonite – It is rich with sodium ion

It has better swelling properties

When it mixes with sand, the volume increases 10 to 20 times.

High dry strength, so lower risk of erosion

Better tolerance of variation in water content

Low green strength

High resistance to burn out

Southern Bentonite - It is rich with calcium ion

It has low dry strength and high green strength

Its properties can be improved by treating it with soda ash (sodium carbonate)

Water:- Used to activate the clay

Generally 2 to 8% of water is required

Other materials added:- Cereal binder – (2%) – to increase the strength Pitch (by product of coke) – (3%) – to improve hot strength

Saw dust (2% ) – To increase permeability

### **Testing sand properties:-**

Sample preparation can be done by mixing various ingredients like sand, clay and moisture.

During mixing, the lump present in sand should be broken up properly. The clay should be uniformly enveloped and the moisture should be uniformly distributed.

The equipment used for preparation of moulding sand is known as Mueller.

This is of two types.

(i) Batch Mueller- Consists of one/two wheels and equal no. of blades connected to a single driving source. The wheels are large and heavy.

(ii) Continuous Mueller- In this type, there are two bowls with wheel and ploughs. The mixture is fed through hopper in one bowl. After muelled, it is moved to another bowl. This type of Mueller is suitable for large scale production.

**Moisture content:-**

1st method - 50g of moulding sand sample is dried at 1050C to 1100C for 2hrs. The sample is then weighed.

Wt. diff \* 2= % of moisture content

2nd method - Moisture teller can be used for measuring moisture content. The Sand is dried suspending sample on fine metallic screen allowing hot air to flow through sample. This method takes less time in comparison to the previous one.

3rd method - A measured amount of calcium carbide along with moulding sand in a separate cap is kept in the moisture teller. Both should not come in contact with each other. Apparatus should be shaken vigorously such that the following reaction takes place.  $\text{CaC}_2 + 2\text{H}_2\text{O} \rightarrow \text{C}_2\text{H}_2 + \text{Ca}(\text{OH})_2$

The acetylene coming out will be collected in space above the sand raising the pressure. A pressure gauge connected to the apparatus would give directly the amount of acetylene generated, which is proportional to the moisture present.

**Clay content:-**

A 50g of sand sample is dried at 1050C to 1100C and is taken in a 1lt. glass flask. 475ml distilled water and 25ml of a 1% solution of caustic soda (NaOH 25g/l) is added to it. The sample is thoroughly stirred (5 mins). The sample is then diluted with fresh water upto 150 mm mark and then left undisturbed for 10mins to settle. The sand settles at bottom and the clay floats. 125mm of this water is siphoned off and again topped to the same level. The process is repeated till water above the sand becomes clear. Then the sand is removed and dried by heating. The difference in weight multiplied by 2 will give the clay % of sand.

**Sand grain size:-**

For sand grain size measurement, the moulding sand sample should be free from moisture and clay. The dried clay free sand grains are placed on the top sieve of sieve shaker (gradually decreasing mesh size). The sieves are shaken continuously for 15 mins. After this the sieves are taken apart and the sand over each sieve is weighed. The amount retained on each sieve is multiplied by the respective weightage factor, summed up and then divided by the total mass of the sample which gives the grain fineness number.

$$\text{GFN} = \frac{\sum M_i f_i}{\sum f_i}$$

$M_i$  = multiplying factor for the  $i$ th sieve

$F_i$  = amount of sand retained on the  $i$ th sieve

**Permeability:-**

Rate of flow of air passing through a standard specimen under a standard pressure is known as permeability number.  $P = \frac{V H}{p A T}$

$V$  = volume of air = 2000 cm<sup>3</sup>

$H$  = height of sand specimen = 5.08 cm

$P$  = air pressure, 980 Pa (10 g/cm<sup>2</sup>)

$A$  = cross sectional area of sand specimen = 20.268 cm<sup>2</sup>

$T$  = time in min. for the complete air to pass through

Inserting the above standard values in the expression we get,  $P = \frac{501.28}{P.T}$

$P.T$

Permeability test is conducted for two types of sands

(a) Green permeability – permeability of green sand

(b) Dry permeability – permeability of the moulding sand dried at 105°C to 1100°C to remove the moisture completely

**Strength:-**

Measurement of strength of moulding sand is carried out on the universal sand- strength testing M/C. The strength can be measured in compression, shear & tension. The types of sand that can be tested are green, dry, core sands.

**Green compressive strength:-**

Stress required to rupture the sand specimen under compressive loading refers to the green compressive strength. It is generally in the range of 30 to 160KPa.

**Green shear strength:-**

The stress required to shear the specimen along the axis is represented as green shear strength. The range is 10 to 50 KPa.

**Dry strength:-**

The test is carried out with a standard specimen dried between 105 to 110°C for 2 hours. The range found is from 140 to 1800KPa.

**Mould hardness:-**

A spring loaded steel ball (0.9kg) is indented into standard sand specimen prepared. If no penetration occurs, then the hardness will be 100. And when it sinks completely, the hardness will be 0 indicating a very soft mould.

**Moulding sand properties:-**

The properties of moulding sand depends upon the variables like –

- sand grain shape and size
- Clay types and amount
- moisture content
- method of preparing sand mould

**Sand grains:-**

The grain shape could be round or angular. Angular sand grains require high amount of binder, where as round sand grains have low permeability. Similarly the grain size could be of coarse or fine. Coarse grains have more void space which increases the permeability. Fine grains have low permeability, but provide better surface finish to the casting produced. The higher the grain size of the sand, higher will be the refractoriness.

**Clay and water:-**

Optimum amount water is used for a clay content to obtain maximum green strength. During sand preparation, clay is uniformly coated around sand grains. Water reacts with the clay to form a linkage of silica - water – clay-water- silica throughout the moulding sand. Amount of water required depends on the type and amount of clay present. Additional water increases the plasticity and dry strength, but decreases the green strength. There is a maximum limit of green compression strength. This type of sand is known as clay saturated sand and used for cast iron and heavy non ferrous metal casting. This type of sand reduces some of the casting defects like erosion, sand expansion, cuts & washes. These sands have green compression strength in a range of 100 to 250 KPa.

**CORES:-**

Cores are used for making cavities and hollow portions. These are made up of sand and are used in permanent moulds. Core are surrounded by molten metal and therefore subjected to thermal and mechanical conditions. So the core should be stronger than the moulding sand. Desired characteristics of a core:-

- (1) Dry strength- It should be able to resist the metal pressure acting on it.
- (2) Green strength- It should be strong enough to retain its shape.
- (3) Refractoriness- Core material should have higher refractoriness.

- (4) Permeability- Core materials should have high permeability.
- (5) Collapsibility- (ability to decrease in size). It is likely to provide resistance against shrinkage.
- (6) Friability- Ability to crumble
- (7) Smoothness- good finish to the casting
- (8) Low gas emission- minimum

**Core sand:-**

The core sand should contain grains, binders and additives. Sand- The silica sand without clay is used as a core sand material. Coarse silica is used in steel foundries where as fine silica is used for cast iron and non ferrous alloys.

Binders:- The normal binders used are organic in nature, because this will burnt away by the heat of molten metal and make the core collapsible during cooling. The binders generally used are linseed oil, core oil, resins, dextrin, molasses etc. Core oils are the mixture of linseed, soy, fish, petroleum oils and coal tar.

**Types of cores:-**

Two types:-

**(a) Green sand core:-** This is obtained by the pattern itself during moulding. Green sand has low strength, so is not suitable for deep holes.

**(b) Dry sand core:-** This is made with special core sands in separate core box, baked & placed in mould. Different types of dry sand cores are

-Unbalanced core -cover core -drop  
core -balanced core -vertical core

**Core prints:-** Core prints are used to position the core securely and correctly in mould cavity. It should take care of the weight of the core and upward metallostatic pressure of molten metal.



## Pouring, Gating design:

A good gating design should ensure proper distribution of molten metal without excessive temperature loss, turbulence, gas entrapping and slags. If the molten metal is poured very slowly, since time taken to fill the mould cavity will become longer, solidification will start even before the mould is completely filled. This can be restricted by using super heated metal, but in this case solubility will be a problem. If the molten metal is poured very faster, it can erode the mould cavity. So gating design is important and it depends on the metal and molten metal composition. For example, aluminium can get oxidized easily. Gating design is classified mainly into two (modified: three) types: Vertical gating, bottom gating, horizontal gating.

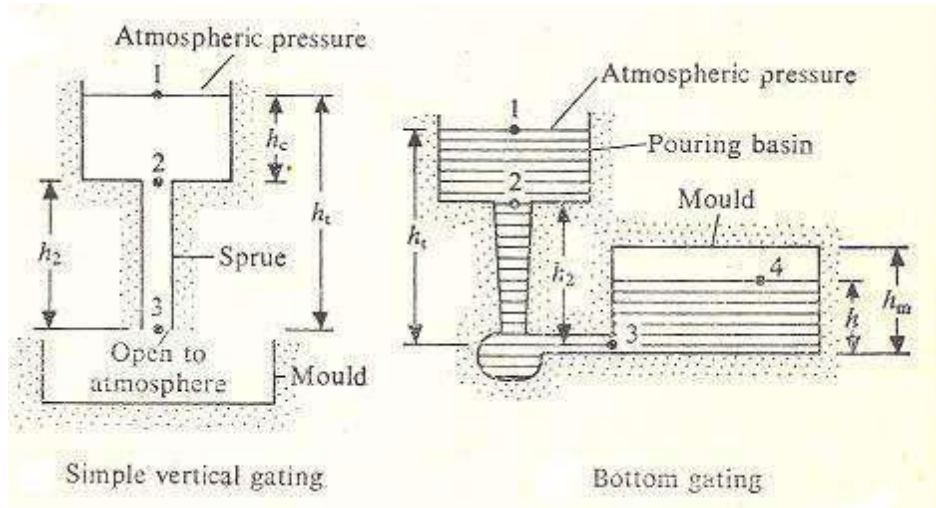

Vertical gating: the liquid metal is poured vertically, directly to fill the mould with atmospheric pressure at the base end.

Bottom gating: molten metal is poured from top, but filled from bottom to top. This minimizes oxidation and splashing while pouring.

Horizontal gating is a modification of bottom gating, in which some horizontal portions are added for good distribution of molten metal and to avoid turbulence

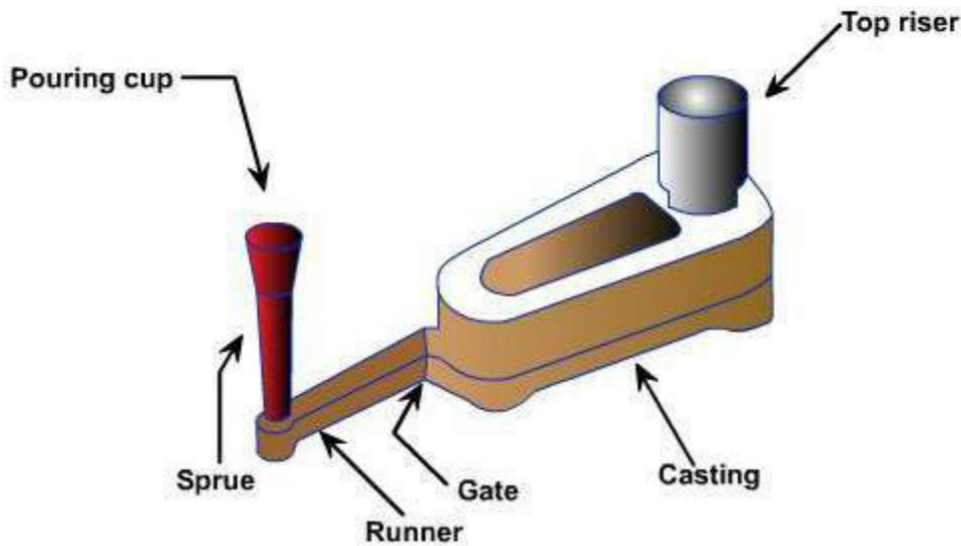

### Analysis of pouring and filling up mould

#### (a) Vertical gating

For analysis we use energy balance equation like Bernoulli's equation

$$h_1 + \frac{p_1}{\rho g} + \frac{v_1^2}{2g} + F_1 = h_3 + \frac{p_3}{\rho g} + \frac{v_3^2}{2g} + F_3$$

Assuming  $p_1 = p_3$  and level at 1 is maintained constant, so  $v_1 = 0$ ; frictional losses are neglected.

The energy balance between point 1 and 3 gives,

$$gh_t = v_3^2 / 2 \quad v_3 = \sqrt{2gh_t}$$

Here  $v_3$  can be referred as velocity at the sprue base or say gate,  $v_g$

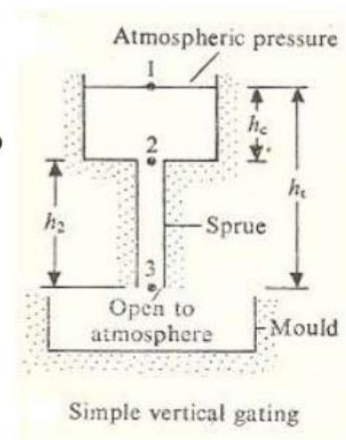

**Continuity equation:** Volumetric flow rate,  $Q = A_1v_1 = A_3v_3$

Above two equations say that sprue should be tapered.

As the metal flows into the sprue opening, it increases in velocity and hence the cross-sectional area of the channel must be reduced

Otherwise, as the velocity of the flowing molten metal increases toward the base of the sprue, air can be aspirated into the liquid and taken into the mould cavity.

To prevent this condition, **the sprue is designed with a taper**, so that the volume flow rate,  $Q = Av$  remains the same at the top and bottom of the sprue.

The mould filling time is given by,  $t_f = \frac{V}{Q} = \frac{V}{A_g v_3}$

$A_g$  = cross-sectional area of gate;  $V$  = volume of mould

**Note:** This is the minimum time required to fill the mould cavity. Since the analysis ignores friction losses and possible constriction of flow in the gating system; the mould filling time will be longer than what is given by the above equation.

### (b) Bottom gating

$$h_1 + \frac{p_1}{\rho g} + \frac{v_1^2}{2g} + F_1 = h_3 + \frac{p_3}{\rho g} + \frac{v_3^2}{2g} + F_3$$

Apply Bernoulli's eqn. between points 1 and 3 and between 3 and 4 is equivalent to modifying  $v_3$  equation in the previous gating.

$$v_g = v_3 = \sqrt{2g(h_t - h)}$$

Effective head

Between 3 and 4:

Assume:

- $v_4$  is very small
- All KE at 3 is lost after the liquid metal enters the mould

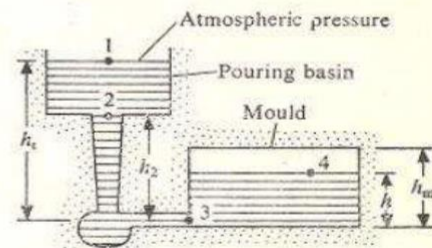

(b) Bottom gating

Assuming in the mould the height moves up by ' $dh$ ' in a time ' $dt$ ';  $A_m$  and  $A_g$  are mould area and gate area, then

$$A_m dh = A_g v_g dt$$

Combining above two eqns., we get  $\frac{1}{\sqrt{2g}} \frac{dh}{\sqrt{h_t - h}} = \frac{A_g}{A_m} dt$

$$\frac{1}{\sqrt{2g}} \int_0^{h_m} \frac{dh}{\sqrt{h_t - h}} = \frac{A_g}{A_m} \int_0^{t_f} dt \Rightarrow t_f = \frac{A_m}{A_g} \frac{1}{\sqrt{2g}} 2(\sqrt{h_t} - \sqrt{h_t - h_m})$$

### Aspiration effect

**Aspiration effect:** entering of gases from baking of organic compounds present in the mould into the molten metal stream. This will produce porous castings. **Pressure anywhere in the liquid stream should not become negative.**

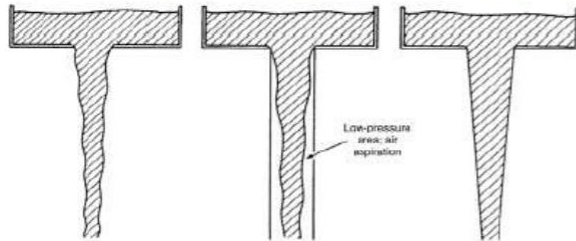

Free falling liquid

Metal flow with aspiration effect

A tapered sprue without aspiration effect

### Case 1: straight Vs tapered sprue

**Pressure anywhere in the liquid stream should not become negative.**

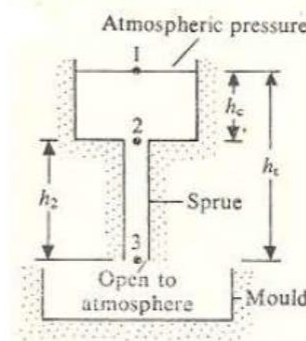

(a) Simple vertical gating

$$gh_2 + \frac{p_2}{\rho_m} + \frac{v_2^2}{2} = \frac{p_3}{\rho_m} + \frac{v_3^2}{2}$$

#### Points 2 & 3

$\rho_m$  = density of molten metal

Let in the limiting case,  $p_2 = p_3$ , then from above equation

$$\frac{v_3^2}{2} = gh_2 + \frac{v_2^2}{2}$$

We know that,  $v_2 = \frac{A_3}{A_2} v_3 = Rv_3$

Combining above two eqns.,  $\frac{v_3^2}{2g} = h_2 + \frac{R^2 v_3^2}{2g}$   $R^2 = 1 - \frac{2gh_2}{v_3^2}$

We know that between points 1 and 3,  $gh_t = v_3^2 / 2$

Put this in  $R^2$  eqn, we get,  $R^2 = 1 - \frac{h_2}{h_t} = \frac{h_c}{h_t}$   $R = \frac{A_3}{A_2} = \sqrt{\frac{h_c}{h_t}}$

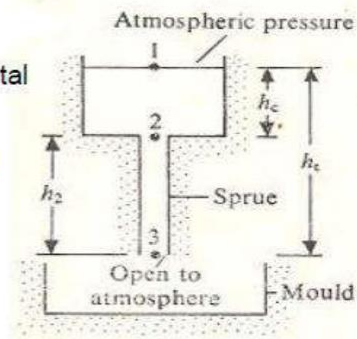

(a) Simple vertical gating

**Ideal and actual profiles of sprue**

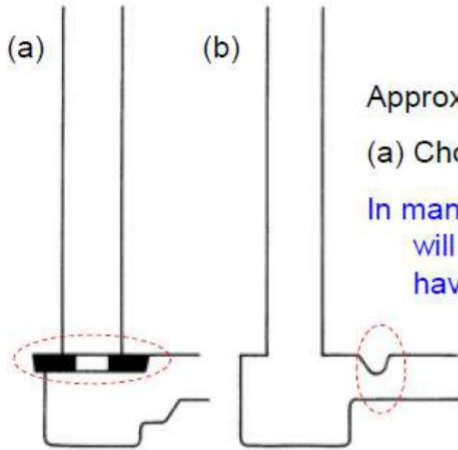
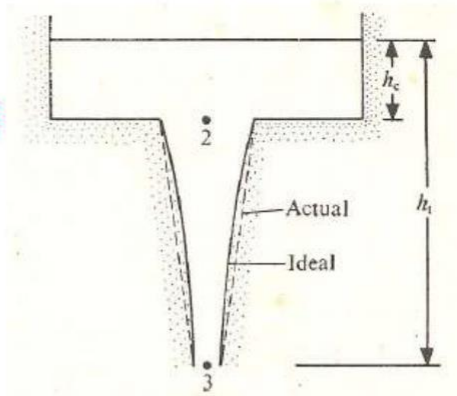

Approximating tapered spure using choke mechanism

(a) Choke core, (b) Runner choke

In many high production casting systems, tapered sprue will not be provided. Instead it is compensated by having chokes at the end of sprue or runner.

**Case 2: sudden change in flow direction**

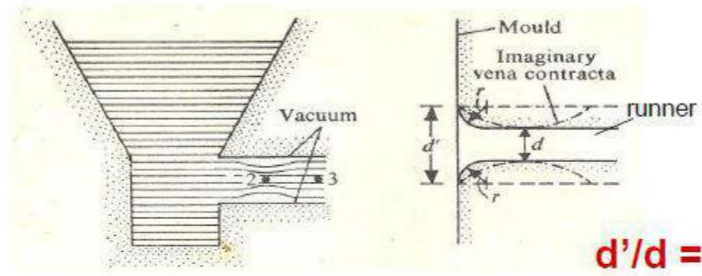
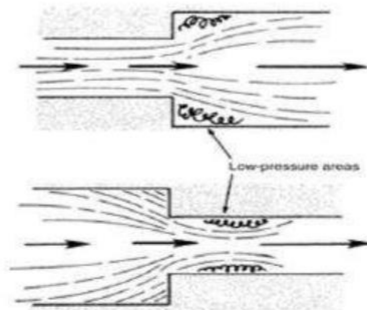

**$d'/d = 1.3$**

A sharp change in flow direction is avoided by designing the mould to fit vena contracta.

## Preventing impurities and turbulence in casting

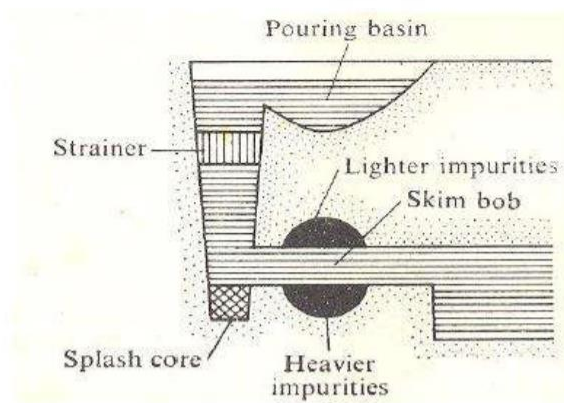

The items provided in the gating system to avoid impurities and turbulence are:

### Pouring basin:

This reduces the eroding force of the liquid metal poured from furnace. This also maintains a constant pouring head. Experience shows that pouring basin depth of 2.5 times the sprue entrance diameter is enough for smooth metal flow. Radius of 25R (mm) is good for smooth entrance of sprue.

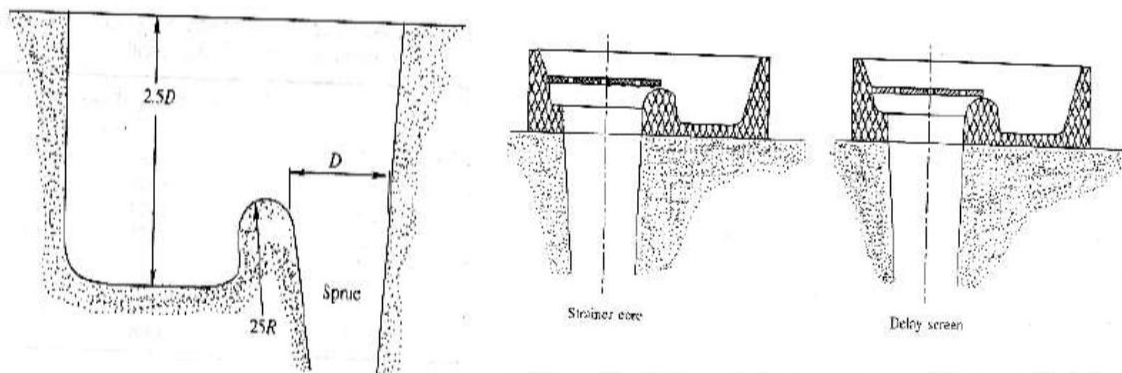

P Rao, *Manufacturing Technology: Foundry, Forming And Welding*

### Delay screen/Strainer core:

A delay screen is a small piece of perforated screen placed on top of the sprue. This screen actually melts because of the heat from the metal and this delays the entrance of metal into the sprue, maintaining the pouring basin head. This also removes dross in the molten metal.

Strainer core is a ceramic coated screen with many small holes and used for same purpose.

**Splash core:** provided at the end of the sprue length which reduces the eroding force of the liquid metal

**Skim bob:** this traps lighter and heavier impurities in the horizontal flow

## Gating ratios

**Gating ratio:** sprue area : runner area : gate area

**Non-pressurized:**

has choke at the bottom of the sprue base, has total runner area and gate areas higher than the sprue area. No pressure is present in the system and hence no turbulence. But chances of air aspiration is possible. **Suitable for Al and Mg alloys.**

In this, Gating ratio = 1 : 4 : 4

**Pressurized:**

Here gate area is smallest, thus maintaining the back pressure throughout the gating system. This backpressure generates turbulence and thereby minimizes the air aspiration even when straight sprue is used.

**Not good for light alloys, but good for ferrous castings.**

In this, Gating ratio = 1 : 2 : 1

## RISER:-

Most alloys shrink during solidification. As a result of this volumetric shrinkage, voids are formed which are known as hot spots. So a reservoir of molten metal is maintained from which the metal can flow steadily into the casting. These reservoirs are known as risers. Design considerations:- The metal in riser should solidify at the end and the riser volume should be sufficient for compensating the shrinkage in the casting. To solve this problem, the riser should have highervolume.

### Types of Riser:-

**(a) top riser-** This type of riser is open to the atmosphere. It is very conventional & convenient to make. It loses heat to the atmosphere by radiation & convection. To reduce this, insulation is provided on top such as plaster of paris and asbestos sheets.

**(b) blind riser :-** This type of riser is surrounded by the moulding sand and loses heat very slowly.

**(c) Internal rise:-** It is surrounded on all sides by casting such that heat from casting keeps the metal in the riser hot for a longer time. These are used for cylindrical shapes or hollow cylindrical portions casting.

**Chill:-** Metallic chills are used to provide progressive solidification or to avoid the shrinkage cavities. These are large heat sinks. Use of chill will form a hard spots, which needs further machining.

### **Melting & casting Quality**

Melting is a major factor which controls the quality of casting. The different methods for melting foundry alloys are pit furnace, open hearth furnace, rotary furnace and cupola furnace etc. The choice of furnace depends amount & type of alloy.

### **CUPOLA:-**

It consists of a cylindrical steel shell with its interior lined with heat resisting fire bricks. There is a drop door at the bottom after closing which proper sand bed could be prepared. This sand bed provides proper refractory bottom for molten metal & coke. Above the sand bed, there is a metal tapping hole which will be initially closed with clay known as "bot". Opposite & above the metal tapping hole, there is a slag hole where slag is trapped. Above the slag hole, there is a wind box which is connected to air blowers. Air enters to the cupola through the tuyeres. Above the charging platform, there is a charging hole through which charge is put into the cupola. The charge consists of the pig iron, scrap iron, coke and fluxes.



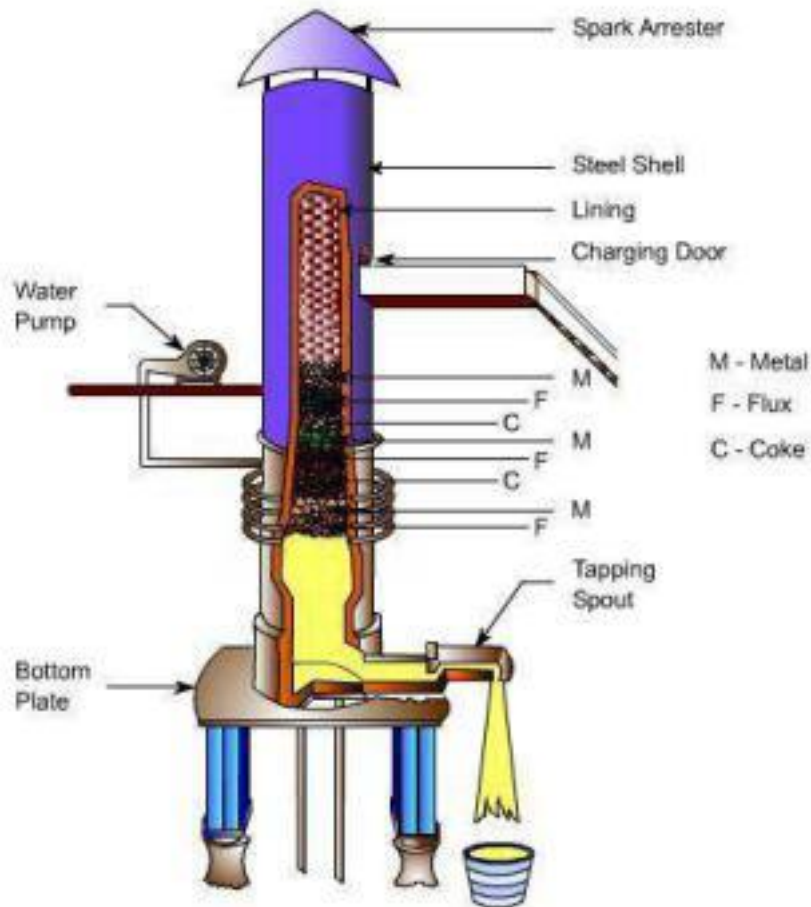

Schematic diagram of a cupola

### Operation:-

First the drop door at the bottom is closed. Sand bed with slope towards tap hole is rammed. Coke bed of suitable height is prepared above the sand bed and is ignited through the tap hole. After proper ignition, alternate layers of charge, flux & coke are fed through the charge door. Then the charge is allowed to soak in the heat and the air blast is turned on. Within 5 to 10mins, the molten metal is collected through the tap hole. When enough metal is collected in the well of the cupola, the slag is drained off through the slag hole. Then the molten metal is collected in the ladles and is transported to the moulds with a minimum time loss.

Fluxes are added in the charge to remove the oxides & other impurities present in the metal. The flux commonly used is lime stone ( $\text{CaCO}_3$ ) in a

proportion of 2 to 4% of the metal charge. Others fluxes used are dolomite, sodium carbonate, calcium carbide. Flux reacts with oxides to form compounds having low melting point and lighter so that it will float on the metal pool.

### **Charge calculations:-**

**Carbon:-** When charge comes through the coke bed, some amount of carbon is picked up by the metal depending on the temperature and the time when the metal is in contact with the coke. It is of the order of 0.15% carbon.

**Silicon:-** It is Oxidised in the cupola and there will be a loss of 10% silicon. It may be as high as 30%. To increase the silicon content, ferrosilicon is added to the metal.

**Manganese:-** There is a loss of 15 to 20% manganese during melting process. The content of manganese can be increased by the addition of ferromanganese.

**Sulphur-** There will a sulphur pick up in a range of 0.03 to 0.05%.

### ***Other furnaces:***

Other furnaces include

- Open hearth furnace
- Rotary furnace
- Crucible furnace
- Immersion heated furnace

Based on the source of heating, they can be classified as

- Electrical heating furnace (arc, resistance or induction)
- Fossil full fired furnace (solid, oil/gaseous fuel)

**ELECTRIC ARC FURNACE:**

For heavy steel castings, the open hearth type furnace with electric arc/oil fired would be suitable. These furnaces are suitable for ferrous materials. It consists of a bowl shaped bottom known as hearth lined with refractory bricks and granular refractory material. Heat is directly transferred to the charge by electric arc from the electrodes. Tilting mechanism forward is used for metal tapping and backward is for deslagging.

**INDUCTION FURNACE:**

This type of furnace is suitable for all types of materials. The heat source is isolated from charge and slag. The flux gets necessary heat directly from the charge instead of the heat source. The stirring effect of electric current would cause fluxes to be entrained in the melt.

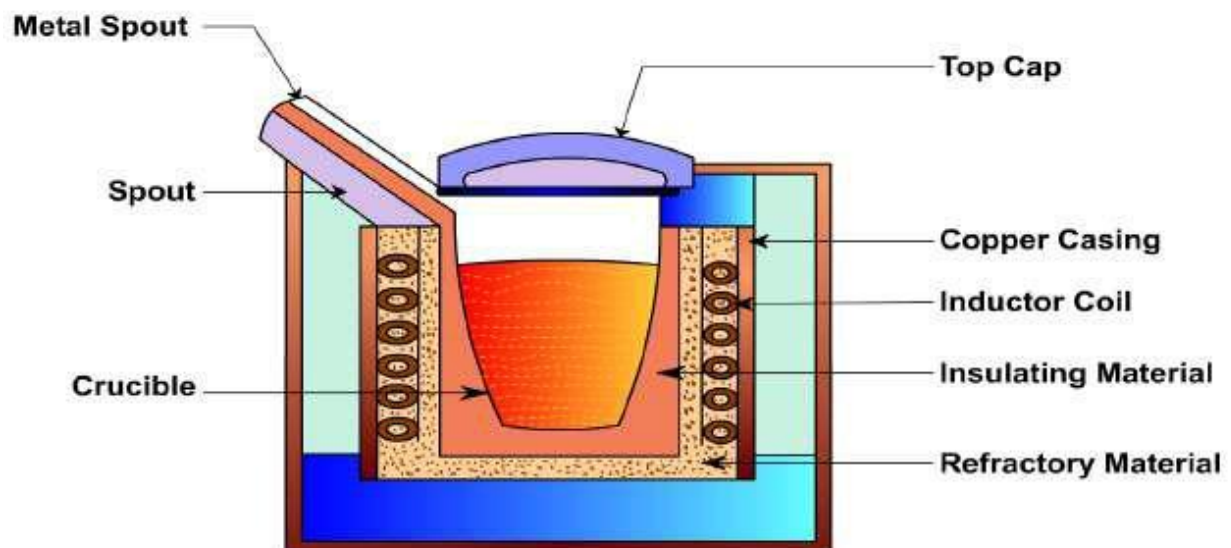

**Induction Furnace**

## Defects in sand castings

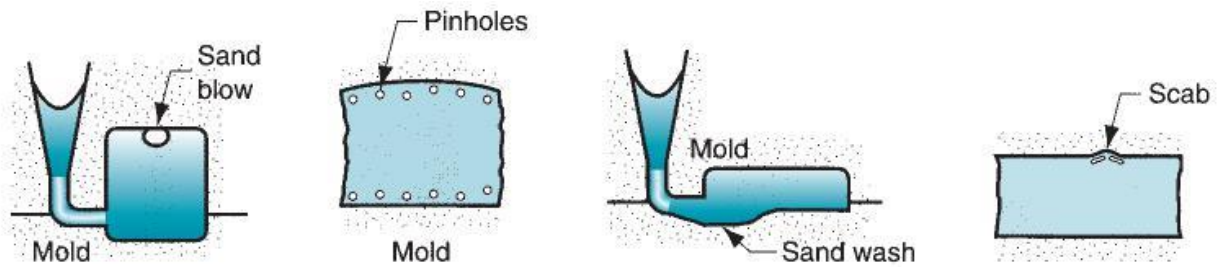

**Sand blow and Pinholes:** defect consisting of a balloon-shaped gas cavity or gas cavities caused by release of mold gases during pouring. It is present just below the casting top surface. Low permeability, bad gas venting, and high moisture content of the sand mold are the usual causes.

**Sand wash:** surface dip that results from erosion of the sand mold during pouring. This contour is formed in the surface of the final cast part.

**Scab:** It is caused by portions of the mold surface flaking off during solidification and gets embedded in the casting surface.

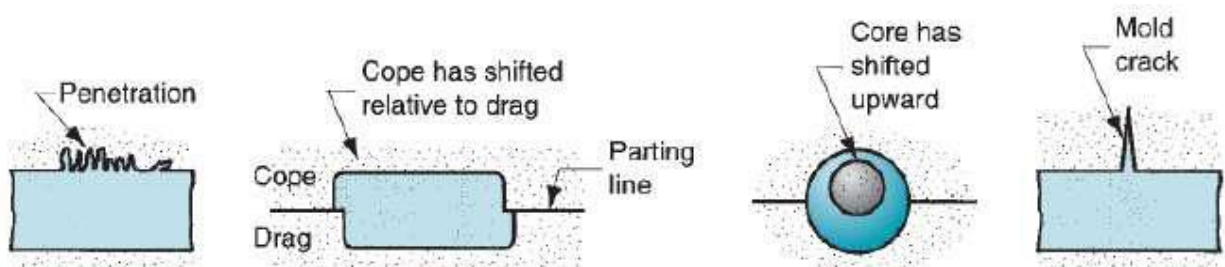

**Penetration:** surface defect that occurs when the liquid penetrates into the sand mold as the fluidity of liquid metal is high, After solidifying, the casting surface consists of a mixture of sand and metal. Harder ramming of sand mold minimize this defect.

**Mold shift:** defect caused by displacement of the mold cope in sideward direction relative to the drag. This results in a step in the cast product at the parting line.

**Core shift:** displacement of core vertically. Core shift and mold shift are caused by buoyancy of the molten metal.

**Mold crack:** 'fin' like defect in cast part that occurs when mold strength is very less, and a crack develops, through which liquid metal can seep.

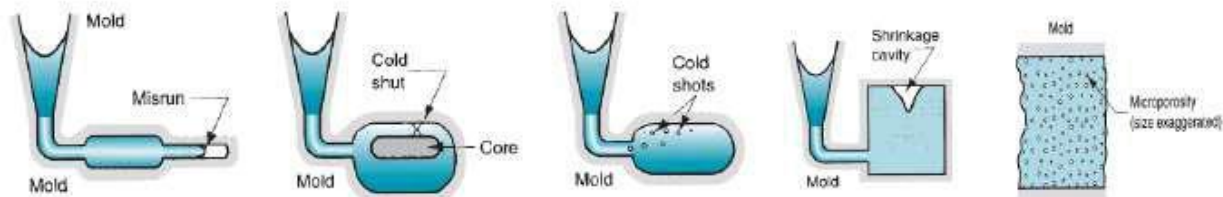

**Misruns:** castings that solidify before completely filling the mold cavity. This occurs because of (1) low fluidity of the molten metal, (2) low pouring temperature, (3) slow pouring, (4) thinner cross-section of the mold cavity.

**Cold Shuts:** This defect occurs when two portions of the metal flow together but no fusion occurs between them due to premature freezing.

**Cold shots:** forming of solid globules of metal that are entrapped in the casting. Proper pouring procedures and gating system designs can prevent this defect.

**Shrinkage cavity:** cavity in the surface or an internal void in the casting, caused by solidification shrinkage that restricts the amount of molten metal present in the last region to freeze. It is sometimes called as 'pipe'. Proper riser design can solve this problem.

**Microporosity:** network of small voids distributed throughout the casting caused by localized solidification shrinkage of the final molten metal.

**Inoculation** is a common and necessary practice used in foundries that produce gray and ductile iron castings. Often performed just prior to pouring, inoculation refers to a procedural step undertaken to improve the solidified structure of the metal, and therefore its mechanical properties.

The process:

- \* promotes the formation of small and uniformly dispersed Type A graphite in gray iron and increases the nodule count in ductile iron. Type A graphite of the correct size provides the best mechanical properties of the iron;
- \* minimizes the formation of primary iron carbides (also called chill or white iron)

**Degassing processes** There are 3 methods of degassing which are in practice

- i) Ladle degassing
- ii) Stream degassing
- iii) Circulation degassing

All these processes are carried out in ladles. Ladle degassing Ladle containing molten steel is placed in a chamber which is then evacuated. After a determined time ladle is removed from the chamber and is teemed for casting. The Arrangement of ladle with porous plug and hopper for degassing Ladle is provided with a porous plug at its bottom to purge argon gas as shown in the figure. In a vacuum chamber the ladle is placed. The vacuum chamber is equipped with a hopper so as to make additions of elements as and when it is needed. For effective degassing of fully killed steel, it is necessary to purge argon through the bottom of the ladle. Stirring the bath enhances rate of gas removal. Vigorous removal of gases causes metal splashing too. Therefore ladle is not filled completely and about 25% of its height is kept as freeboard to accommodate the splashed metal droplets. Pressure is maintained in between 1mmHg to 10mm Hg for effective degassing. During degassing additions are made for deoxidation and alloying. In certain cases ladle is heated to compensate for the loss of heat during degassing. For the effectiveness of degassing , it is necessary that carry-over slag either from BOF or EAF should be as low as possible. Carry-over slag contains

FeO and since oxygen content of steel is in equilibrium with FeO content of slag, oxygen content of steel increases. Stirring gas is introduced either from top through the roof by a submerged refractory tube or through the porous plug fitted at the bottom of the ladle. Electromagnetic stirring is employed for degassing. For this purpose ladle has to be made of non magnetic austenitic stainless steel or stainless window could be provided. For certain grades of alloy steels, both induction stirring and arc heating are employed for degassing. The final content of gas in steel depends on degree of vacuum and time of treatment. Hydrogen is generally reduced to below 2ppm from 4 to 6ppm, nitrogen content of steel is also reduced. The pick-up of nitrogen from the atmospheric air may occur during open pouring of steel, which must be controlled. Ladles are generally lined with high alumina bricks at upper part of the ladle while the lower portion is lined with fireclay. Stream degassing In stream degassing technology, molten steel is teemed into another vessel which is under vacuum. Sudden exposure of molten stream in vacuum leads to very rapid degassing due to increased surface area created by breakup of stream into droplets. The major amount of degassing occurs during the fall of molten stream. Height of the pouring stream is an important design parameter. Stream degassing technology has following variants in the practice i. Ladle to mould degassing Preheated mold with hot top is placed in vacuum chamber. Above the chamber a tundish is placed. Steel tapped in the ladle at superheat equivalent to 30°C is placed above the tundish. Steel is bottom poured in the tundish. One ingot could weigh around as high as 400tons and several heats from different furnaces are used for casting. Figure 26.2 shows arrangement of vessels Figure 26.2: Arrangement of ladle, tundish and mold to degass molten steel ii. Ladle to ladle

degassing In ladle to ladle degassing, a ladle with the stopper rod is placed in a vacuum chamber. Ladle containing molten steel from BOF or EAF is placed on top of the vacuum chamber and the gap is vacuum sealed. Alloy additions are made under vacuum. Stream is allowed to fall in the ladle where molten steel is degassed. Alloy additions are made under vacuum. In some plants degassing is done during tapping. In this arrangement molten steel from EAF is tapped into tundish or pony ladle. From the pony ladle molten stream is allowed to fall into a ladle which is evacuated. Ladle is closed from top with a special cover which contains exhaust opening. Steel with 25°C to 30°C superheat is tapped into ladle.

### **CONTINUOUS CASTING:**

In this process the liquid steel is poured into a double walled bottomless water cooled mould where a solid skin is quickly formed having a thickness of 10 to 25 mm and a semi solid skin emerges from open mould bottom which will be further solidified by water sprays. Molten metal is collected in a ladle and is kept over a refractory lined intermediate pouring vessel called tundish and then poured into water cooled vertical copper mould of 450 to 750 mm long. Before starting casting, a dummy starter bar will be kept at the mould bottom. After starting casting process, as the metal level rises to a height, the starter bar will be withdrawn at equal rate that of the steel pouring rate. Initially metal freezes on to the starter bar as well as periphery of the mould. Solidified shell supports the steel liquid as it moves downwards. The steel shell is mechanically supported by rollers as it moves down through the secondary cooling zone with water.



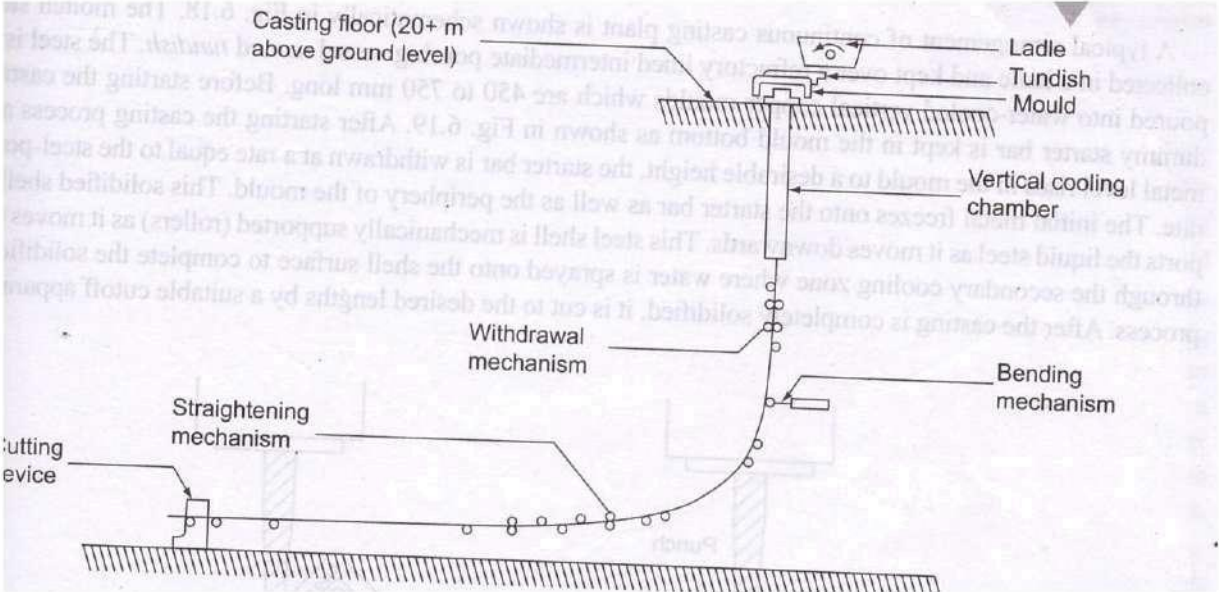

Continuous casting plant

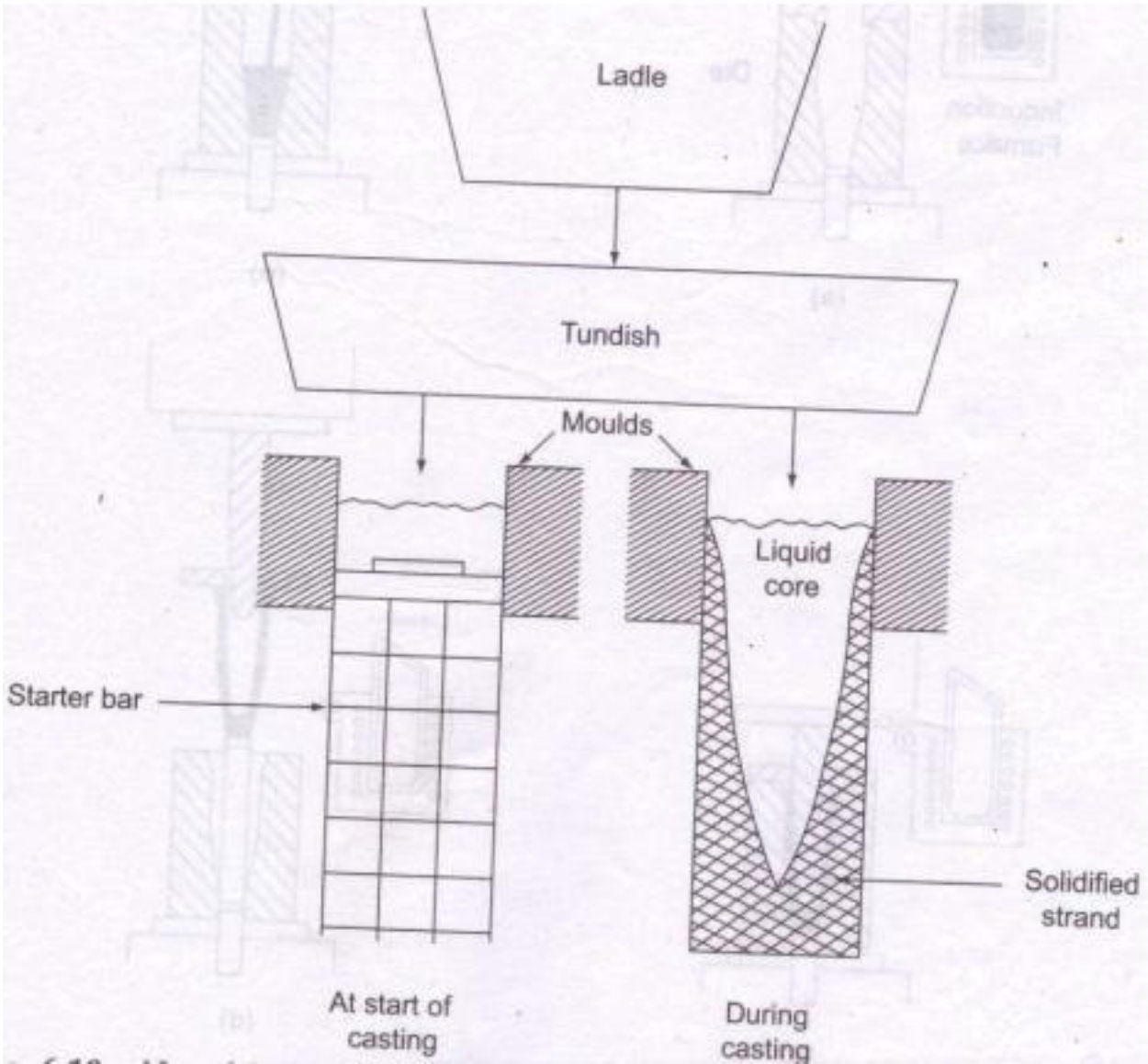

use of dummy starter bar at the start of continuous casting process

**SQUEEZE CASTING:**

It was first developed in Russia. It is a combination of casting and forging process. First the punch and die are separated. The furnace holds the liquid metal at a requisite temperature. Then the metal is put into the die cavity and the punch is lowered to its place forming a tight seal. The metal is under a pressure of 50 to 140 mpa and loses heat rapidly because of the contact with the metallic die. Once the casting is solidified, the punch is retracted.

Adv: very low gas entrapment.

Lower shrinkage cavity.

Lower die costs.

High quality surface.

Application: Mg, Al, Cu alloy

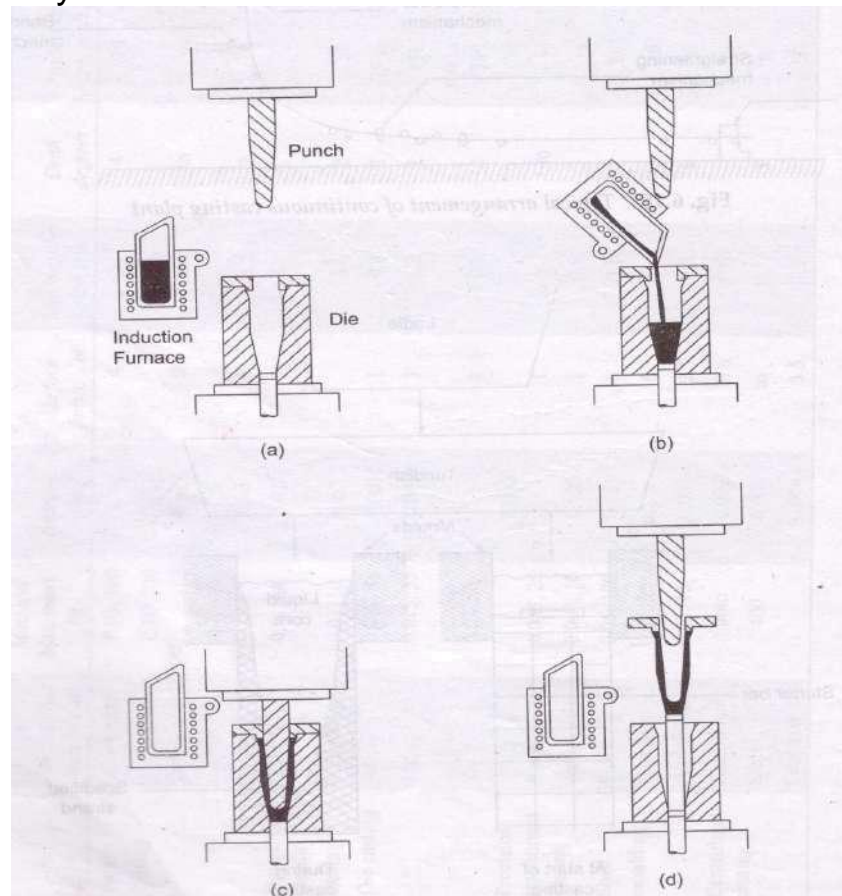

**Investment casting** In this casting process, a pattern made of wax is coated with a refractory material to make the mold surface, after which the wax is melted away while pouring the molten metal. “Investment” means “to cover completely” which refers to the coating of the refractory material

around the wax pattern. This is a precision casting process. Using this we can make castings of high accuracy with intricate details.

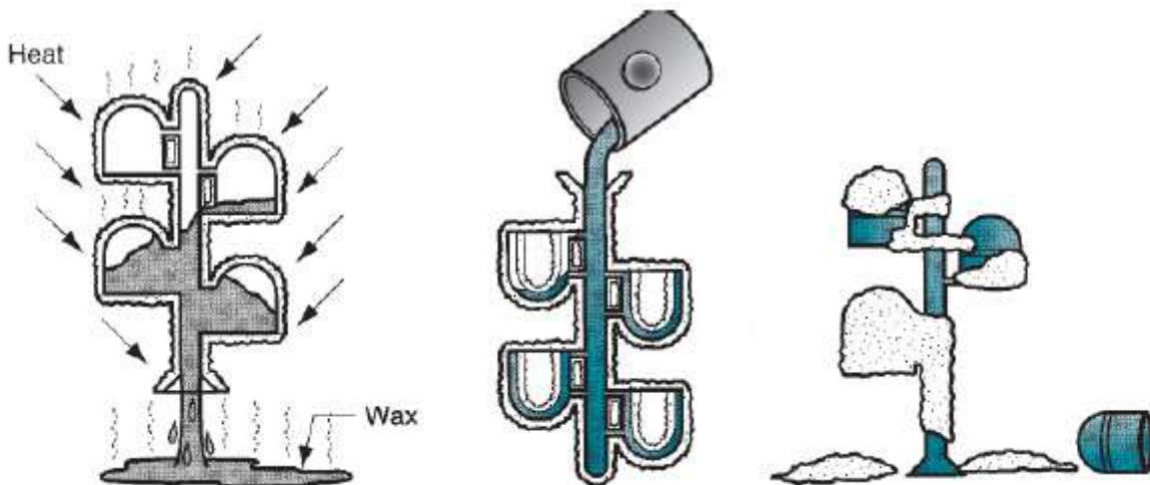
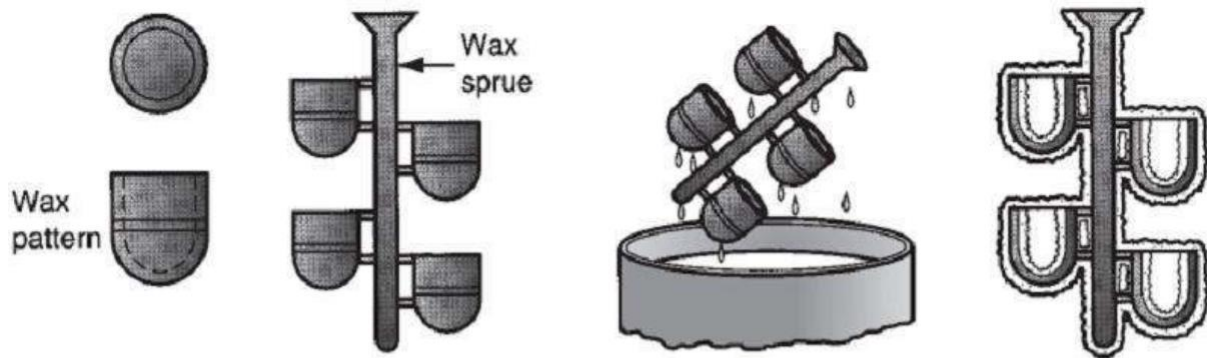

Wax patterns are first made

- several patterns can be attached to a sprue to form a pattern tree, if required
- the pattern tree is coated with a thin layer of refractory material and later covered with thick coating to make the rigid full mold
- Heating of mold in inverted position to melt the wax and permit it to drip out of the cavity
- the mold is preheated to a high temperature so that contaminants are eliminated from the mold
- the molten metal is poured and it solidifies
- the mold is removed from the finished casting

**Refractory coating:**

- Slurry of very fine grained silica or other refractory, in powder form, mixed with plaster to bond the mold into shape. The small grain size of the refractory material delivers smooth surface and captures the intricate depths of the wax pattern.
- Mold is allowed to dry in air for about 8 hours to harden the binder.

**Advantages:**

- (1) Complex and intricate parts can be cast
- (2) tolerances of 0.075 mm are possible
- (3) good surface finish is possible
- (4) In general, additional machining is not required – near net shaped part

**Applications:**

- Steels, stainless steels, high temperature alloys can be cast
- **Examples of parts:** machine parts, blades, components for turbine engines, jewelry, dental fixtures

**Plaster mold and ceramic mold casting****Plaster mold:**

- similar to sand casting, except mold is made of POP and not sand
- To minimize contraction, curing time, reduce cracking, additives like talc and silica flour are mixed with the plaster.
- **Curing time:** 20 mts, **baking time:** several hours
- Permeability is low. This problem is solved by using a special mold composition and treatment known as the **Antioch process**. IN this operation, about 50% of sand is mixed with the plaster, heating the mold in an autoclave, and then drying is done. Good permeability is attained by this treatment.
- Used only for Al, Mg, Cu based alloys

**Ceramic mold:**

- mold is made of refractory ceramic materials which can withstand high temp. than plaster.
- Ceramic molding can be used to cast steels, CI, and other high temp. alloys.

### Permanent mold process

Disadvantage of expendable molding processes is that for every casting a new mold is required.

#### Permanent mold processes:

- using only metal mold for casting
- Molds are generally made of steel, CI
- materials that can be cast: Al, Mg, Cu based alloys, CI (affect the mold life, hence not used)
- cores are also made of metal, but if sand is used then called semi permanent-mold casting
- Advantages: good surface finish, dimension tolerance, rapid solidification causes fine grains to form giving stronger products
- limitations: restricted to simple part geometries, low melting point metals, mold cost is high. Best suitable for small, large number of parts

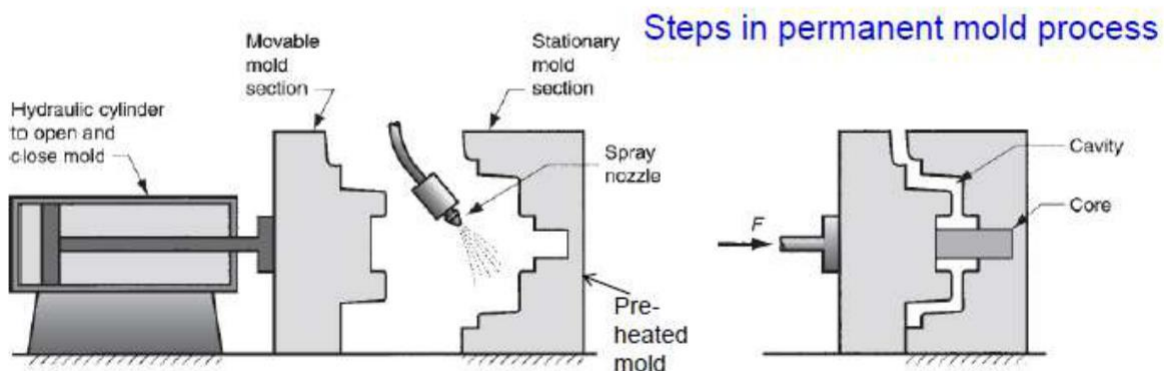

Preheating facilitates metal flow through the gating system and into the cavity.

The coatings aid heat dissipation and lubricate the mold surfaces for easier separation of the cast product

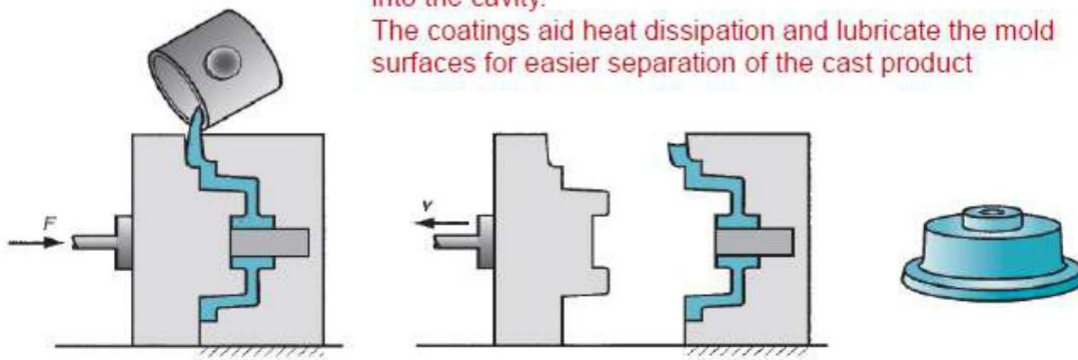

R.Ganesh Narayanan, IITG

## Die casting

In this process, high pressure of app. 7 to 350 MPa is used to pressurize the molten metal into die cavity. The pressure is maintained during solidification.

**Category:** hot chamber machines, cold chamber machines

### hot chamber machines:

- Molten metal is melted in a container attached to the machine, and a piston is used to pressurize metal under high pressure into the die. Typical injection pressures are between 7 and 35 MPa.
- Production rate of 500 parts/hour are common.
- Injection system is submerged into the molten metal and hence pose problem of chemical attack on the machine components. Suitable for zinc, tin, lead, Mg.

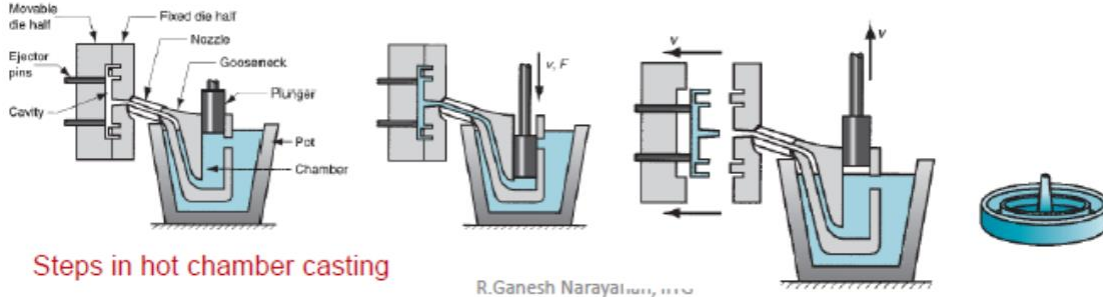

### cold chamber machines:

- Molten metal is poured from an external unheated container into the mold cavity and piston is used to inject the molten metal into the die cavity.
- Injection pressure: 14 to 140 MPa.
- Though it is a high production operation, it is not as fast as hot chamber machines.

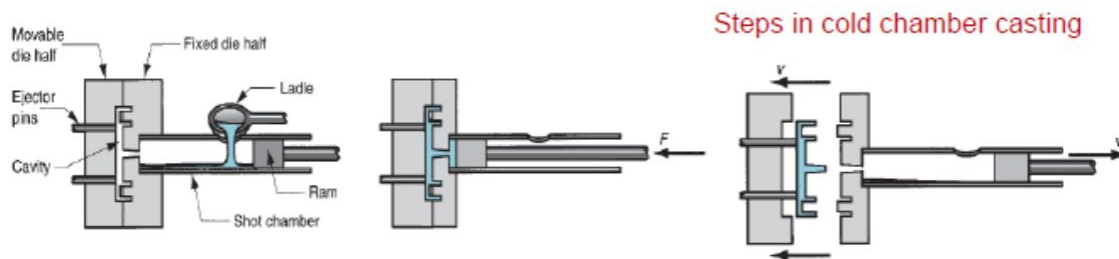

Die casting molds are made of tool steel, mold steel, maraging steels. Tungsten and molybdenum with good refractory qualities are also used for die cast steel, CI.

### Advantages of die casting:

- high production rates and economical
- Close tolerances possible of the order of  $\pm 0.076$  mm
- thin section with 0.5 mm can be made
- small grain size and good strength casting can be made because of rapid cooling

### Centrifugal casting

- In this method, the mold is rotated at high speed so that the molten metal is distributed by the centrifugal force to the outer regions of the die cavity
- includes : true centrifugal casting, semicentrifugal casting

#### True centrifugal casting:

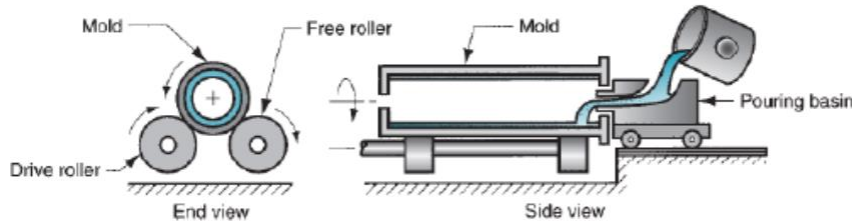

- Molten metal is poured into a rotating mold to produce a tubular part (pipes, tubes, bushings, and rings)
- Molten metal is poured into a horizontal rotating mold at one end. The high-speed rotation results in centrifugal forces that cause the metal to take the shape of the mold cavity. The outside shape of the casting can be non-round, but inside shape of the casting is perfectly round, due to the radial symmetry w.r.t. forces
- Orientation of the mold can be **horizontal or vertical**

#### For horizontal centrifugal casting:

$$\text{centrifugal force} = F = \frac{mv^2}{R} \quad \text{Where } F \text{ – force in N, } m \text{ – mass in kg, } v \text{ – velocity in m/s, } R \text{ – inner radius of mold in m}$$

Here we define G-factor (GF) as the ratio of centrifugal force to weight.

$$GF = \frac{\left(\frac{mv^2}{R}\right)}{mg} = \frac{v^2}{Rg} \quad \text{For horizontal centrifugal casting, GF is equal to 60 to 80}$$

Putting  $v = 2\pi RN/60$  in the above eqn. and after rearrangement gives,

$$N = \frac{30}{\pi} \sqrt{\frac{2g(GF)}{D}} \quad \text{Where } N \text{ is rotational speed in rev/min., } D \text{ is inner diameter of mold in m}$$

If the G-factor is very less, because of the reduced centrifugal force, the liquid metal will not remain forced against the mold wall during the upper half of the circular path but will go into the cavity. This means that slipping occurs between the molten metal and the mold wall, which indicates that rotational speed of the metal is less than that of the mold.



### Semicentrifugal casting:

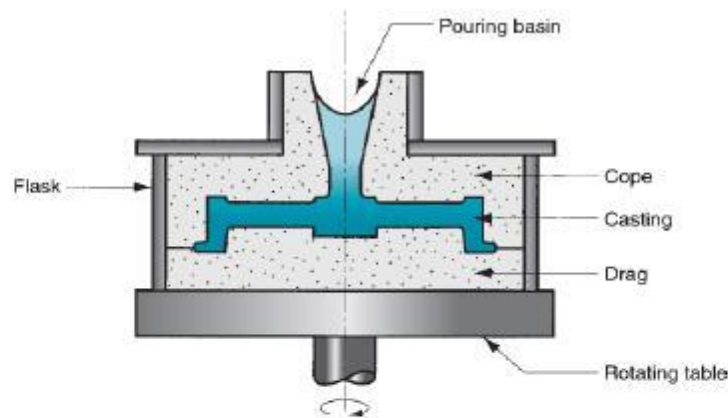

In this process, centrifugal force is used to produce non-tubular parts (solid), and not tubular parts. GF will be around 15 by controlling the rotation speed. Molds are provided with riser at the center.

Generally the density of metal will be more at the outer sections and not at the center of rotation. So parts in which the center region (less denser region) can be removed by machining (like wheels, pulleys) are usually produced with this method.

## Module – II Welding and cutting (12 Lectures)

Fabrication is often known as secondary manufacturing process as the method relies on the raw material obtained from the manufacturing process like extrusion and rolling. Fabrication is a process of joining two or more elements to make a single part. Most common examples are aircraft, ship bodies, bridges, building trusses, welded machine frames, sheet metal parts, etc.

### Classification of Manufacturing Processes

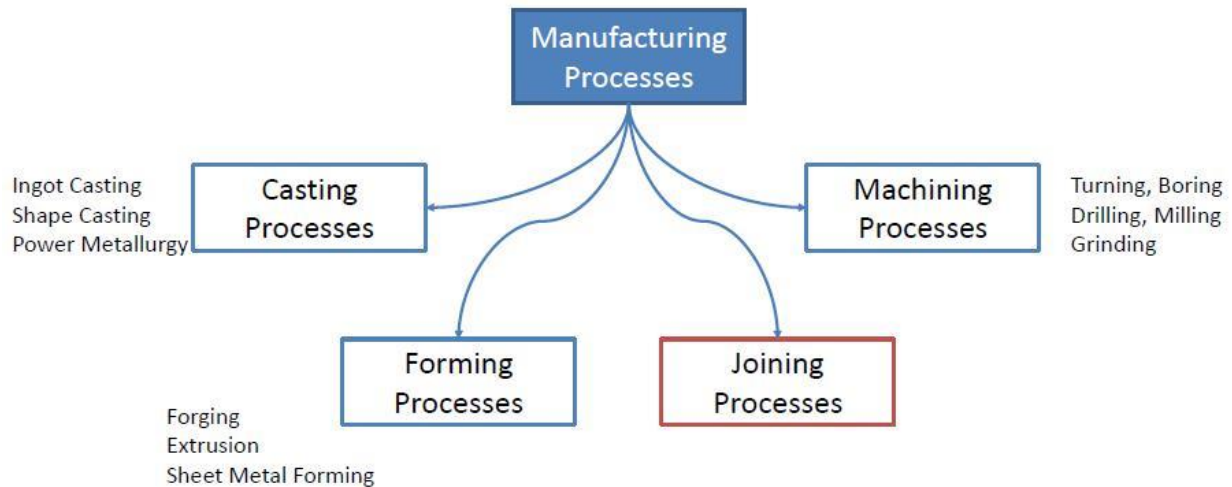

### Classification of Joining Processes

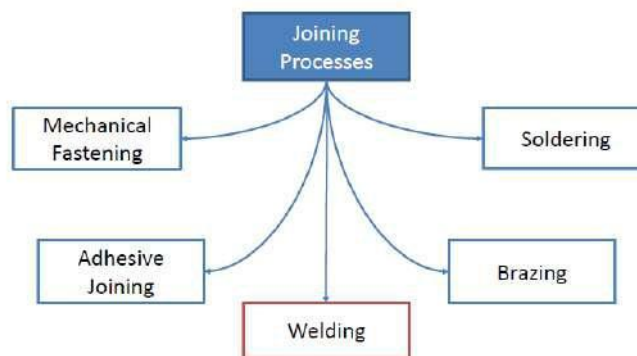

### Different Welding Processes

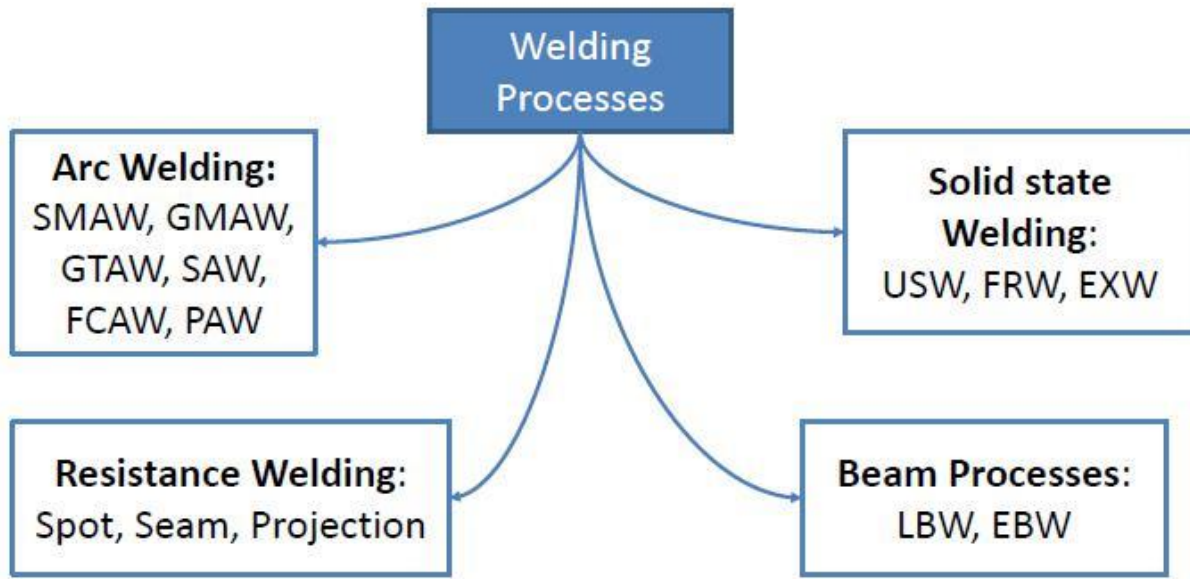

A particular fabrication method depends on number of factors

- Type of assembly

Permanent, semi permanent or temporary

Joining those obtained by bolts or screws and can be disassembled whenever necessary are temporary in nature. Rivets are semi-permanents fastening devices that involve making holes in the mating parts. Here joints can be separated by destroying the rivet without harming the parent elements.

- Materials being joined
- Type of service required

Assembly subjected to heavy loading, impact loading, high temperatures

**Principle of welding:** The welding process is a complex process that involves heat and liquid-metal transfer, chemical reactions. A gradual formation of the welded joint is obtained through liquid-metal deposition and subsequently there is a transformation from cooling into the solid state.

**Brazing** Brazing is a coalescence of a joint with the help of a filler metal whose liquidus temperature is above 4500 and is below the solidus temperature of base metal. In brazing the base metal is not melted. Dissimilar metals can be joined by brazing. Except aluminium and magnesium, brazing can join almost all metals. Brazed joint is not useful for high temperature welding because of the low melting temperature of the filler metal. Here the filler metal reaches the joint by capillary action, it is necessary to control the clearance between two parts. The temperature at which filler metal is entering the joint is also important. Too much clearance doesn't allow capillary force to draw the filler metal into the joint and also insufficient clearance may be too small to allow the filler metal to give rise to an effective strength.

### **Soldering**

Soldering is the method of joining similar or dissimilar metals by means of a filler metal whose liquidus temperature is below 4500. The joint design used for soldering is similar to that of brazing as in both cases filler metals enter the joint by capillary action. Like brazing, soldering also needs solvent cleaning, acid pickling and mechanical cleaning of the joint surface. In order to remove the oxides from the joint surface for avoiding filler metal from oxidizing, fluxes are generally used in soldering.

### **General Considerations:**

Types of joints

Different types of welding joints are classified as butt, lap, corner, tee and edge joints.

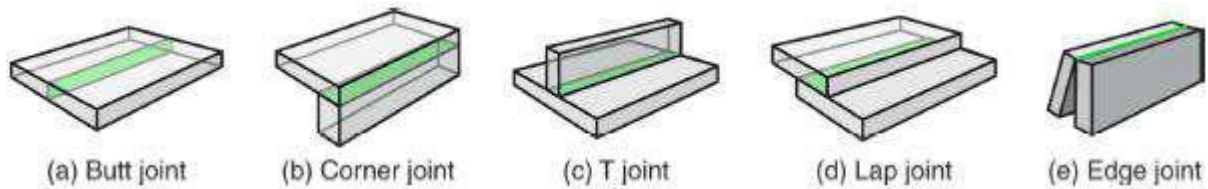

Tensile strength of butt joint depends upon the contact area. In case of lap joint, depending upon the strength requirement, the bonding area chosen. But the limitation of lap joint is that the thickness of joint increases for overlapping of the parts.

For small thickness, Straight edge joints are done and for that edge is prepared in such a way that heat of welding can penetrate the entire depth. To facilitate the process, the joint is widened.

- For very thick plates, the welding needs to be done from both sides.
- The V- joint is easier to make and the amount of extra metal to be filled in the joint increases greatly with an increase in the thickness.
- A U joint is preferable when  $t$
- Groove preparation

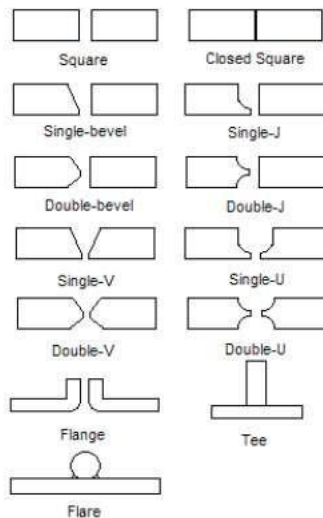

Comparison of Various Joining Methods									
Method	Characteristics								
	Strength	Design	Small parts	Large parts	Tolerances	Reliability	Ease of manufacture	Ease of inspection	Cost
Arc welding	1	2	3	1	3	1	2	2	2
Resistance welding	1	2	1	1	3	3	3	3	1
Brazing	1	1	1	1	3	1	3	2	3
Bolts and nuts	1	2	3	1	2	1	1	1	3
Riveting	1	2	3	1	1	1	3	1	2
Fasteners	2	3	3	1	2	2	2	1	3
Seaming and crimping	2	2	1	3	3	1	3	1	1
Adhesive bonding	3	1	1	2	3	2	3	3	2

Note: 1 = very good; 2 = good; 3 = poor. For cost, 1 is the lowest.

## GAS WELDING

Gas welding is also named as oxy-fuel gas welding (OFW). Gas welding derives heat from the combustion of fuel gas such as acetylene in combination with oxygen. The process is a fusion welding process where the joint is completely melted to obtain the fusion. **Necessary considerations for gas welding**

### Fuel Gases

Fuel gas for Gas welding used is acetylene due to its high temperature in the flame. Thereby the gas welding may be known as oxy-acetylene welding (OAW).

Following table shows the useful fuel gases for gas welding with their calorific values and temperatures.

Table.1. Characteristics of fuel gases Gas		Chemical Formula	Heat content, MJ/m <sup>3</sup>		Flame temperature, °C
Primary		Secondary		Total	
Acetylene	C <sub>2</sub> H <sub>2</sub>	18.97	36.03	55	3100
Propylene	C <sub>3</sub> H <sub>6</sub>	16.38	71.62	88	2500
Propane	C <sub>2</sub> H <sub>8</sub>	9.38	83.62	93	2450
Methyl acetylene propadiene	C <sub>3</sub> H <sub>4</sub>	21.00	70.00	91	2927
Hydrogen	H <sub>2</sub>	-	-	10	2390
Natural gas	CH <sub>4</sub> +H <sub>2</sub>	0.41	36.59	37	2350

Three basic types of oxyacetylene flames used in oxyfuel-gas welding and cutting operations: (a) neutral flame; (b) oxidizing flame; (c) carburizing, or reducing, flame.

The gas mixture in (a) is basically equal volumes of oxygen and acetylene.

(d) The principle of the oxyfuel–gas welding process.

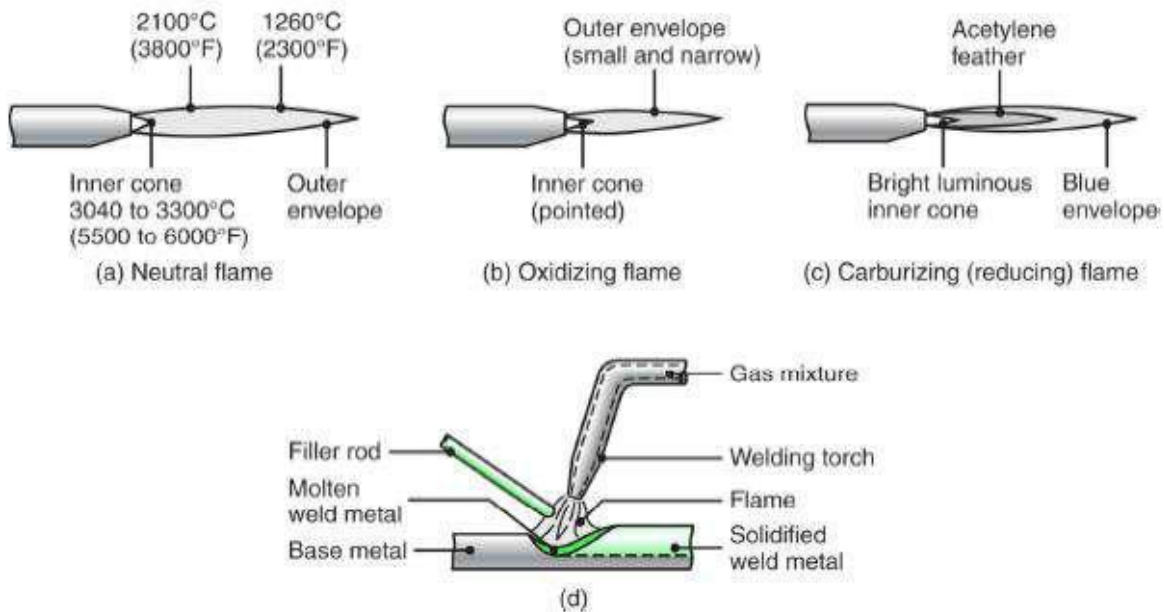

(a) General view of, and (b) cross section of, a torch used in oxyacetylene welding. The acetylene valve is opened first. The gas is lit with a spark lighter or a pilot light. Then the oxygen valve is opened and the flame adjusted. (c) Basic equipment used in oxyfuel–gas welding. To ensure correct connections, all threads on acetylene fittings are left handed, whereas those for oxygen are right handed. Oxygen regulators usually are painted green and acetylene regulators red.

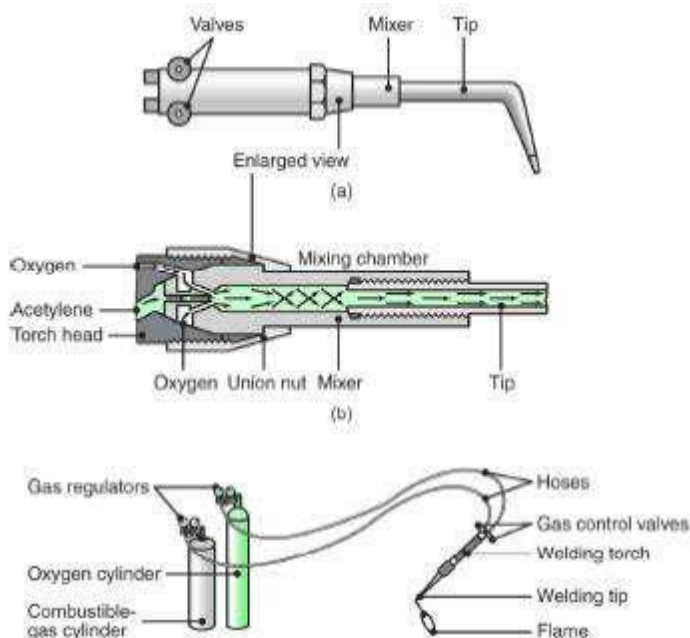

Schematic illustration of the pressure-gas welding process: (a) before and (b) after. Note the formation of a flash at the joint; later the flash can be trimmed off.

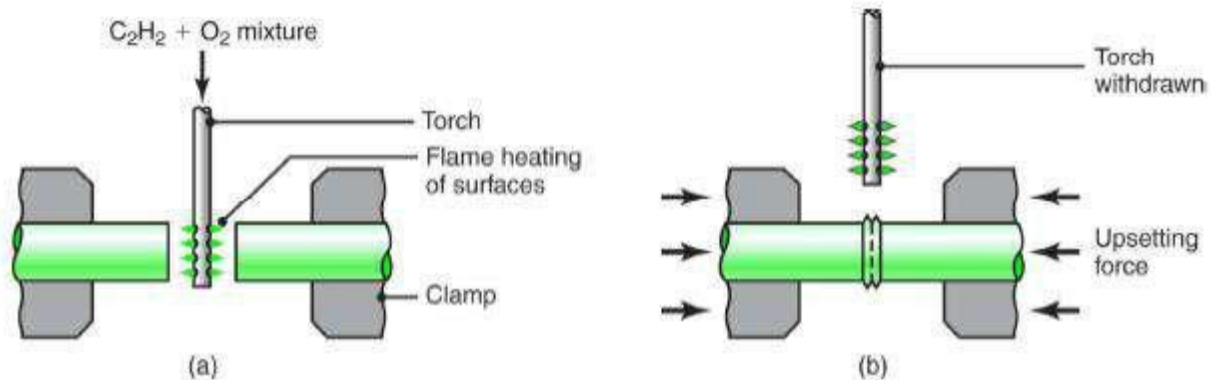

The acetylene valve on the torch is opened slightly with the help of a friction spark lighter. The acetylene valve is opened to get the required flow of acetylene. The oxygen valve is slowly opened till the intermediate flame feather of the reducing flame.

- The choice of torch size depends upon the thickness of metal to be joined.
- Torch should be held at an angle of 30 to 50 degrees from the horizontal plane.
- Torch movement either oscillatory or circular.
- Torch tip should be positioned above the metal plate so that the white cone is at a distance of 1.5 to 3.0mm from the plate.
- For forehand welding the torch is moved in the direction of tip.

## Electric arc welding

### Arc welding

Arc welding processes use the heat generated by an electric arc to melt the faying surfaces of the base metal in order to develop a weld joint.

### Manual metal arc welding

In this process, the heat is generated by an electric arc between base metal and a consumable electrode. As the electrode movement is manually controlled hence it is termed as manual metal arc welding. This process is extensively used for depositing weld metal because it



is easy to deposit the molten weld metal at right place where it is required and it doesn't need separate shielding. This process is commonly used for welding of the metals, which are comparatively less sensitive to the atmospheric gases. This process can use both AC and DC. The constant current DC power source is invariably used with all types of electrode (basic, rutile and cellulosic) irrespective of base metal (ferrous and non-ferrous). However, AC can be unsuitable for certain types of electrodes and base materials. Therefore, AC should be used in light of manufacturer's recommendations for the electrode application. In case of DC welding, heat liberated at anode is generally greater than the arc column and cathode side. The amount of heat generated at the anode and cathode may differ appreciably depending upon the flux composition of coating, base metal, polarity and the nature of arc plasma. In case of DC welding, polarity determines the distribution of the heat generated at the cathode and anode and accordingly the melting rate of electrode and penetration into the base metal are affected.

### **Tungsten Inert-Gas Welding (TIG)**

Tungsten inert-gas (TIG) welding or gas tungsten arc is an inert gas shielded arc welding using a non-consumable electrode. This electric arc is produced by the passage of current through a conductive ionized inert gas that provides shielding of the electrode, molten weld pool and solidifying weld metal from contamination by the atmosphere. The process may be used with or without the addition of filler metal using metal rods. (a) The gas tungsten-arc welding process, formerly known as TIG ( for tungsten-g inert-gas) welding. (b) Equipment for gas tungsten-arc welding operations.

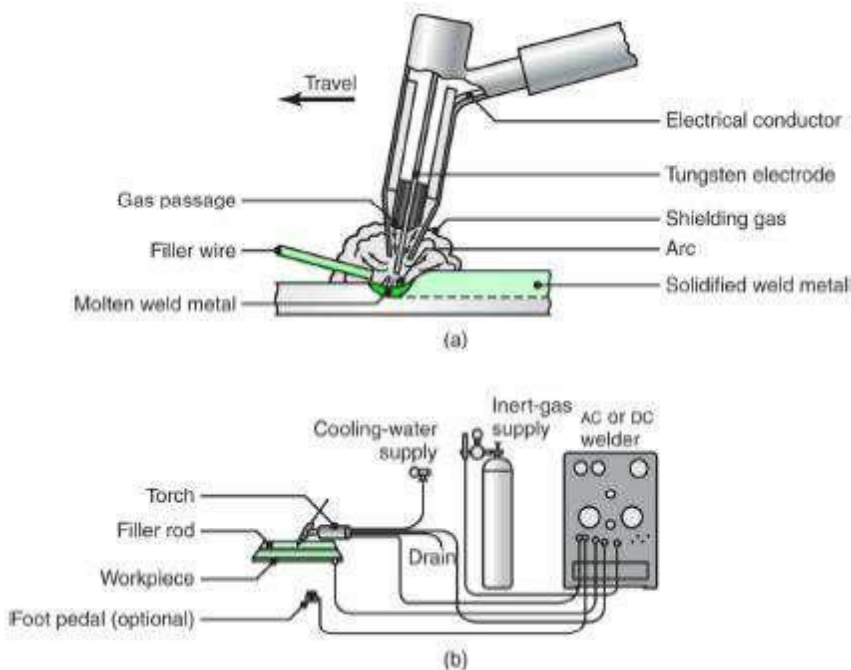

**Electrode:** In TIG welding, tungsten refers to the element used on the electrode. The function of the electrode is to serve as one of the electric terminals which supplies the heat required to the weld. Care must be taken so that the tungsten electrode does not come contact with the weld pool in any way in order to avoid its contamination resulting on faulty weld. Pure tungsten is less expensive and will carry less current. Some other elements may be added to the tungsten, like cerium, lanthanum, thorium and zirconium creating electrode alloys in order to improve arc stability, emissivity and bring higher melting points. The electrode may contain 1 to 2% thoria(thorium oxide) mixed along with the core tungsten or tungsten with 0.15 to 0.40% zirconia (zirconium oxide).The thoriated tungsten electrodes carry high current and more desirable as they can strike and maintain a stable arc. The zirconia added with tungsten is better than pure tungsten but inferior to thoriated tungsten electrode.

**Tungsten inert gas welding set up:**

It consists of a welding torch at the center of which is the tungsten electrode. The inert gas supplied to the welding zone through the annular path surrounding the tungsten electrode to effectively displace the atmosphere around the weld puddle.

### **GAS METAL ARC WELDING (GMAW)**

This is also known as Metal inert-gas arc welding (MIG) because it utilizes a consumable electrode. There are other gas-shielded arc-welding processes utilizing consumable electrodes such as flux-cored arc welding, all of which coming under MIG. It's quite suitable for thicker sheets because filler metal requirement in welding process makes gas-tungsten arc welding (GTAW or TIG ) difficult to use, which is more suitable for thin sheets. (a) Schematic illustration of the gas metal-arc welding process, formerly known as MIG (for metal inert-gas) welding. (b) Basic equipment used in gas metal-arc welding operations.

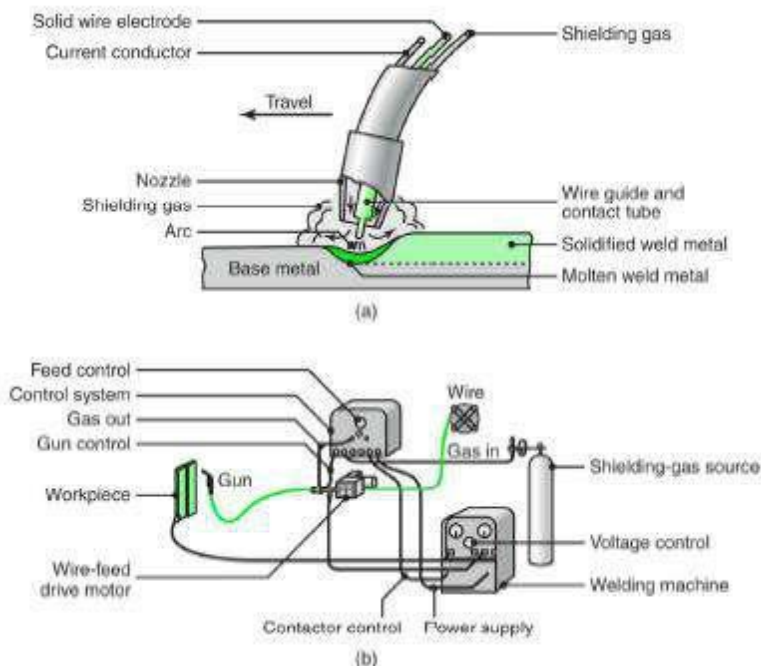

The consumable electrode is in the form of wire reel fed at a constant rate through the feed rollers. The welding torch is connected to the gas supply cylinder, which provides the necessary inert gas. The electrode and the work piece are connected to the welding power supply. The power supply is always of the constant voltage type. The current from the welding machine is changed by the rate of feeding of

electrode wire. Normally, DC arc-welding machine are used for GMAW with electrode positive (DCEP). The DCEP increases the metal- deposition rate and also provides a stable arc and smooth electrode metal transfer. With DCEN the arc become highly unstable and also results in spatter. But special electrodes having calcium and titanium oxide mixtures as coatings are found to be good for steel with DCEN.

- **Metal Transfer**

- Metal transfer takes place from the electrode to the joint in GMAW process. The metal transfer is done in different ways depending on the current and voltage used for a given electrode.
- Short circuit or dip transfer,
- Spray transfer,
- Pulsed spray transfer, and
- Rotating spray transfer.

The short-circuiting metal transfer occurs with relatively low current settings of the order of 75 to 175 A for an electrode diameter of 0.9 mm. The number of times that the pinching takes place depends on the inductance of welding machine used and the parameters set. The rate at which the short-circuiting current increases is controlled by inductance of the welding machines. Too low an inductance gives rise to very high short-circuiting current and consequently high pinching rate. With high inductance, the short-circuiting becomes low and results in somewhat lower pinching force. The effect of inductance is measured in terms of response rate (raising rate of current due to short-circuiting, kA/s). It can be observed that the

optimum response rate depends on electrode wire size. Hence, the welding machines to be used for short-circuiting transfer make use of a variable choke system which can be tuned for different wire sizes. The frequency of metal transfer may be of the order of 50 to 200 per second. This rate also depends on the open-circuit voltage and wire-feed rate employed.

## **SHIELDING GASES**

Argon, helium, nitrogen, oxygen, carbon dioxide and mixture of the above gases in various proportions are used in GMAW as shielding gases.

Argon is the most widely used of all the shielding gases, because it reduces the spatter and concentrates the arc, which in turn gives deep penetration welds. In addition, argon ionizes easily requiring smaller arc voltages and also has lower thermal conductivity and hence conducts heat very slowly from the arc to the weld zone. Thus, it is good for welding thin sheets. Because of the lower voltages employed, it is suitable for out-of-position welding. For spray transfer of metal a large percentage of argon is required. Helium is the most expensive of all the shielding gases. Due to its better thermal conductivity it is suitable for thicker sheets as well as for metals having higher thermal conductivity such as copper and aluminium. The filler metal-deposition rate by helium is much higher compared to argon because of the higher current-carrying capacity.

The arc in carbon dioxide shielding gas is unstable and therefore a short arc is to be used to reduce the metal spatter. It is the least expensive of all the shielding gases. Since about 7.5% of the carbon dioxide decomposes into carbon monoxide and oxygen in the arc, deoxidizers such as aluminium and silicon are to be used while using carbon dioxide. It is a heavy gas and therefore it covers the weld zone very well. The metal transfer is globular only with the carbon dioxide shielding gas.

Sometimes the mixtures of gases such as argon-helium, argon-carbon dioxide, argon-oxygen are used for special applications. Shielding gases should always flow in a laminar manner without causing any turbulence because turbulence causes weld contamination. The gas flow rates to be used depend upon the thickness of the sheet being welded, the position of the weld as well as the base material.

### **ELECTRODES**

The electrode wire comes generally in the form of coils and of normal sizes may be of the order of 0.5 to 3.2 mm. Depending upon the base material, various wire compositions are available. For steels, electrodes wire having deoxidizers are used because, the deoxidizers help in the reduction of oxidation of the weld metal as well as the porosity. The electrode wire is produced by wire drawing, and uniform diameter throughout otherwise the arc may saunter.

### **SUBMERGED ARC WELDING (SAW)**

It is used for faster welding jobs. It is possible to use larger welding electrodes (12 mm) as well as very high currents (4000 A) so that very high metal deposition rates of the order of 20 kg/h or more can be achieved with this process. Also, very high welding speeds (5 m/min) are possible in saw. Some submerged arc welding-machines are able to weld plates of thicknesses as high as 75 mm in butt joint in a single pass. Though it can weld very small thickness, of the order of 1 mm, it is very economical for larger welds only. Schematic illustration of the submerged-arc welding process and equipment. The un-fused flux is recovered and reused.

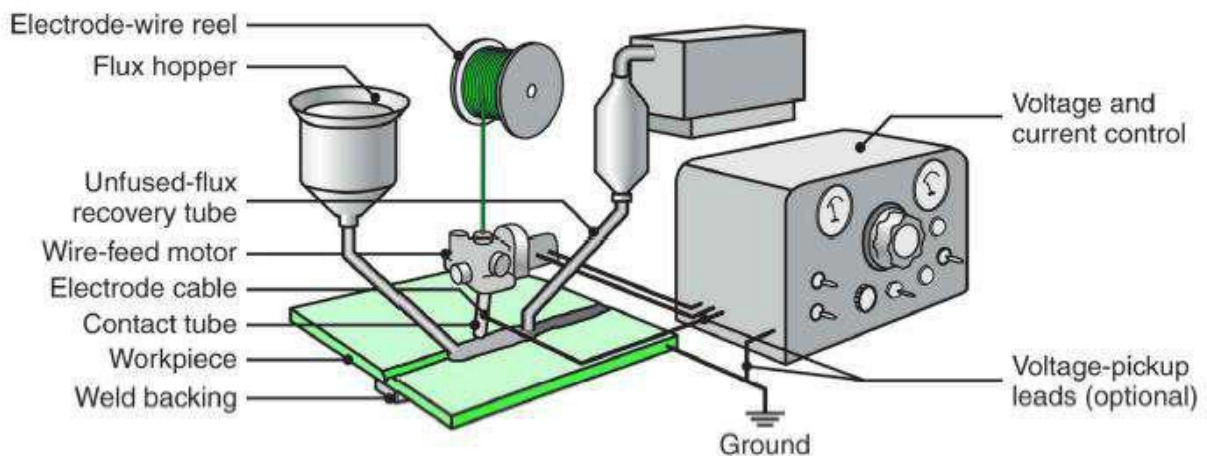

The arc is produced in the same manner as in GMAW. The welding zone is completely covered by means of large amount of granulated flux, which is delivered ahead of welding electrode by means of flux-feed tube. The arc between the electrode and the work-piece is completely submerged under the flux and is not visible from outside. A part of the flux melts and forms the slag, which covers the weld metal. The unused flux can be recycled.

The power source used with submerged arc welding can either be AC or DC. Both constant voltage and constant current type machines can effectively used though, for larger electrode a constant current type power supply is used. The current ratings of the SAW machines are, in general, two to three times higher that of the GMAW machines.

Arc blow is not encountered with AC supply with a single wire SAW. But sometimes two wires may be used to deposit larger amounts of metal. These two electrode being connected to two separate power sources, the arc blow is likely to occur because of the interference of the two magnetic fields surrounding the two electrodes, if the two currents are in phase. In order to avoid the setting of opposite magnetic fields, the two power supplies are adjusted in such a way that, one of the supply is in peak, and

the other is set to zero current. One of the electrodes is called leading and the other called trailing. In this way the aforementioned problem is reduced. There is no spatter of the molten metal since the arc is completely submerged in the flux. Because of the usage of loose granulated flux to cover the joint, it is difficult to carry out in any position other than the flat or down-hand position. Also, because of large metal pools generation in the SAW process, the out-of-position welds are difficult to carry out.

The electrode wires normally used are of sizes 1.6, 2, 2.5, 3.15, 4, 5, 6.3 and 8mm. The wires should be smooth with no surface imperfections or contaminants. It is difficult to manually feed the wire into the joint because of very high wire-feed rate. As SAW process produces large amount of molten weld metal, it takes sometimes for solidification. Hence, it is imperative in SAW to provide some way of containing this molten metal. Weld metal backing is normally used. The backing slaves can be with or without grooves, but in general, copper plates are used, which can easily be cooled with internal running water, when necessary. For thin plates, plain copper backing plates without any cooling water, would be enough. Pure copper removes heat quickly from the molten weld pool because of its high thermal conductivity.

## **PLASMA ARC WELDING**

Plasma is the state of matter present in between electrodes in any arc. In this part, gas is ionized to make it a conductor of electric current. - PAW uses a non- consumable tungsten electrode and a shielding gas such as argon, helium or a mixture of both with hydrogen. - Plasma torch:- Pure argon gas is allowed through the inner orifice surrounding the tungsten electrode to form plasma gas. The constraining nozzle squeezes the gas to form a concentrated and straight arc and also increases the heat contained per unit volume of the arc (~110000C). Ionization of the arc occurs through a low current pilot arc between electrode and constricting nozzle. This initiates the PAW arc. Due to constriction the plasma gas attains a very high temperature and also provides a low resistance path to initiate the



welding arc between electrode and work piece. This is called transferred arc. Inert shielding gas is allowed to flow through outer gas nozzle which protects the weld metal. Higher ampere rating Constant current or drooper type of dc power supplies are used as power sources. Electrode is taken as negative. PAW is done by "key hole" technique. Due to high temperature the base metal beneath the arc melts completely forming a thin keyhole. With the advancement of the torch the metal melted ahead (down hand welding position) flows into the keyhole. Thus the keyhole travels continuously along the torch direction. Advantages:- Because of arc concentration heat input can be properly controlled and the heat affected zone around the weld metal is small. - Uniform deep penetration can be obtained. - Greater distance between electrode tip and work piece makes use of filler metal rod easier without contamination of electrode. Higher metal deposit rate. Disadvantages:- Expensive frequent replacement requirement of nozzle. Two types of plasma-arc welding processes: (a) transferred and (b) non-transferred. Deep and narrow welds can be made by these processes at high welding speeds.

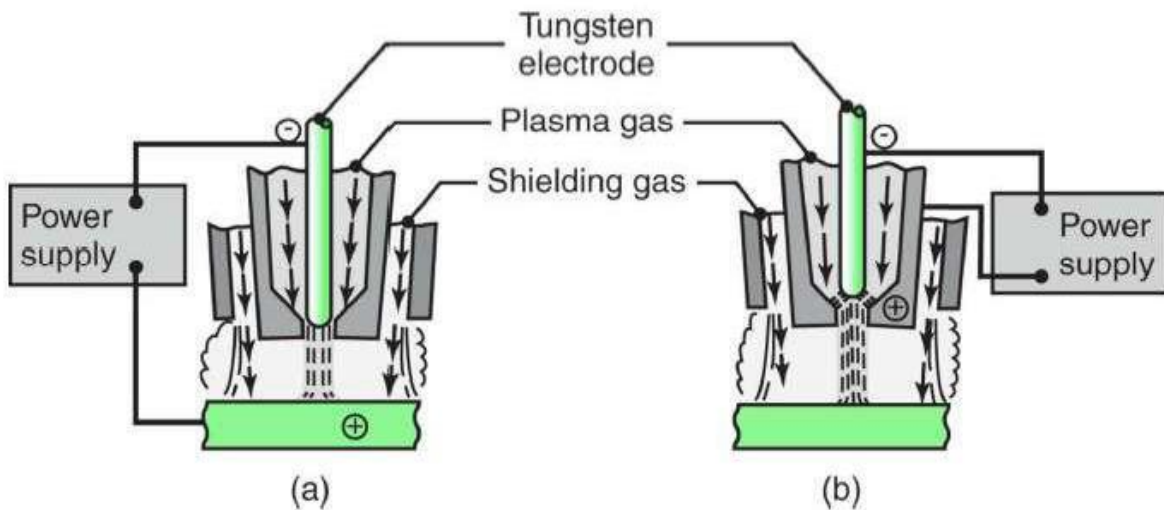

### **THERMIT WELDING**

In thermit welding, weld metal is melted externally using exothermic heat generated by chemical reactions and the melt is supplied between the components to be joined.

### **ELECTROSLAG WELDING**

In electroslag welding weld metal is melted by electrical resistance heating and then it is allowed to cool very slowly for solidification similar to that of casting.

### **ELECTRON BEAM WELDING**

Electron Beam Welding (EBW) is a fusion welding in which coalescence is produced by heating the work piece due to impingement of the

concentrated electron beam of high kinetic energy on the work piece. As the electron beam impinges the workpiece, kinetic energy of the electron beams converts into thermal energy resulting in melting and even evaporation of the work material.

**Principles:**

In general, electron beam welding process is carried out in vacuum. In this process, electrons are emitted from the heated filament called electrode. These electrons are accelerated by applying high potential difference (30 kV to 175 kV) between cathode and anode. The higher the potential difference, the higher would be the acceleration of the electrons. The electrons get the speed in the range of 50,000 to 200,000 km/s. The electron beam is focused by means of electromagnetic lenses. When this high kinetic energy electron beam strikes on the workpiece, high heat is generated on the work piece resulting in melting of the work material. Molten metal fills into the gap between parts to be joined and subsequently it gets solidified and forms the weld joint.

**EBW Equipment:**

An EBW set up consists of the following major equipment:

- Electron gun
- Power supply
- Vacuum Chamber
- Work piece handling device.

**Electron -Gun:** An electron gun generates, accelerates and aligns the electron beam in required direction and spots onto the work piece. The gun is of two types: Self accelerated and work accelerated. The work accelerated gun accelerates the electrons by providing potential difference between the workpiece and cathode. In the self accelerate gun, the electrons are accelerated by applying potential difference between cathode and anode. The anode and cathode are enclosed within the gun itself. The control of electron density is better in this type of electron gun. A schematic of an electron beam gun used in EBW is shown in Fig. Major parts of an electron gun are briefly introduced in the following sections.

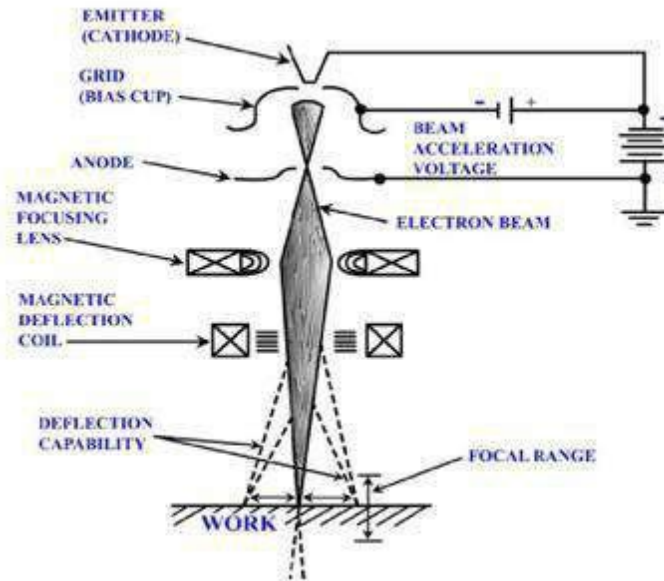

### Schematic of an electron beam gun used in EBW

**Emitter/Filament:** It generates the electrons on direct or indirect heating.

**Anode:** It is a positively charged element near cathode, across which the high voltage is applied to accelerate the electrons. The potential difference for high voltage equipment ranges from 70-150 kV and for low voltage equipment from 15-30 kV.

**Grid cup:** Grid cup is a part of triode type electron gun. A negative voltage with respect to cathode is applied to the grid. The grid controls the beam.

**Focusing unit:** It has two parts: Electron focusing lens and deflection coil. Electron focusing lens focuses the beam into work area. The focusing of the electrons can be carried out by deflection of beams. The electromagnetic lens contains a coil encased in iron. As the electrons enter into the magnetic field, the electron beam path is rotated and refracted into a convergent beam. The extent of spread of the beam can be controlled by controlling the amount of DC voltage applied across the deflection plates.

**Electron gun power supply:** It consists of mainly the high voltage DC power supply source, emitter power supply source, electromagnetic lens and deflection coil source. In the high voltage DC power supply source the required load varies within 3-100 kW. It provides power supply for acceleration of the electrons. The potential difference for high voltage equipment ranges from 70-150 kV and for low voltage equipment 15-30 kV. The current level ranges from 50-1000 mA. In emitter power supply, AC or DC current is required to heat the filament for emission of electrons. However DC current is preferred as it affects the direction of the beam. The amount of current depends upon the diameter and type of the filament. The

current and voltage varies from 25-70 A and 5-30 V respectively. The power to the electromagnetic lens and deflection coil is supplied through a solid state device.

**Vacuum Chamber:** In the vacuum chamber pressure is reduced by the vacuum pump. It consists of a roughing mechanical pump and a diffusion pump. The pressure ranges from 100 kPa for open atmosphere to 0.13-13 Pa for partial vacuum and 0.13-133 mPa for hard vacuum. As the extent of vacuum increases, the scattering of the electrons in the beam increases. It causes the increase in penetration.

**Work Piece Handling Device:** Quality and precision of the weld profile depends upon the accuracy of the movement of work piece. There is also provision for the movement of the work piece to control the welding speed. The movements of the work piece are easily adaptable to computer numerical control.

**Advantages of EBW:**

- High penetration to width can be obtained, which is difficult with other welding processes.
- High welding speed is obtained.
- Material of high melting temperature can be welded.
- Superior weld quality due to welding in vacuum.
- High precision of the welding is obtained.
- Distortion is less due to less heat affected zone.
- Dissimilar materials can be welded.
- Low operating cost.
- Cleaning cost is negligible. Reactive materials like beryllium, titanium etc. can be welded.
- Materials of high melting point like columbium, tungsten etc. can be welded.
- Inaccessible joints can be made.
- Very wide range of sheet thickness can be joined (0.025 mm to 100 mm)

**Disadvantages of EBW:**

- Very high equipment cost.
- High vacuum is required.
- High safety measures are required.
- Large jobs are difficult to weld.
- Skilled man power is required.

**Applications of EBW:**

- Electron beam welding process is mostly used in joining of refractive materials like columbium, tungsten, ceramic etc. which are used in missiles.
- In space shuttle applications wherein reactive materials like beryllium, zirconium, titanium etc. are used.
- In high precision welding for electronic components, nuclear fuel elements, special alloy jet engine components and pressure vessels for rocket plants.
- Dissimilar material can be welded like invar with stainless steel.

### **LASER BEAM WELDING PROCESS**

Laser Beam Welding (LBW) is a fusion joining process that produces coalescence of materials with the heat obtained from a concentrated beam of coherent, monochromatic light impinging on the joint to be welded. In the LBM process, the laser beam is directed by flat optical elements, such as mirrors and then focused to a small spot (for high power density) at the work piece using either reflective focusing elements or lenses. It is a non-contact process, requiring no pressure to be applied. Inert gas shielding is generally employed to prevent oxidation of the molten puddle and filler metals may be occasionally used. The Lasers which are predominantly being used for industrial material processing and welding tasks are the Nd-YAG laser and 1.06  $\mu\text{m}$  wavelength CO<sub>2</sub> laser, with the active elements most commonly employed in these two varieties of lasers being the neodymium (Nd) ion and the CO<sub>2</sub> molecules respectively.

## **Cutting**

Material can be cut with the use of a heat source that melts and removes a narrow zone in the workpiece.

- Can cut contours
- Heat source may be:
  - Torch
  - Electric arc
  - Laser

### **Oxyfuel-gas Cutting (OFC)**

- Similar to Oxyfuel-gas Welding

- Process is particularly suited for steels
- A two-stage chemical process
- Iron combines with oxygen exothermically to oxidize the metal
- Need additional preheat, provided by the fuel gas, to reach melting point

(a) Flame cutting of a steel plate with an oxyacetylene torch, and a cross section of the torch nozzle. (b) Cross section of a flame-cut plate, showing drag lines.

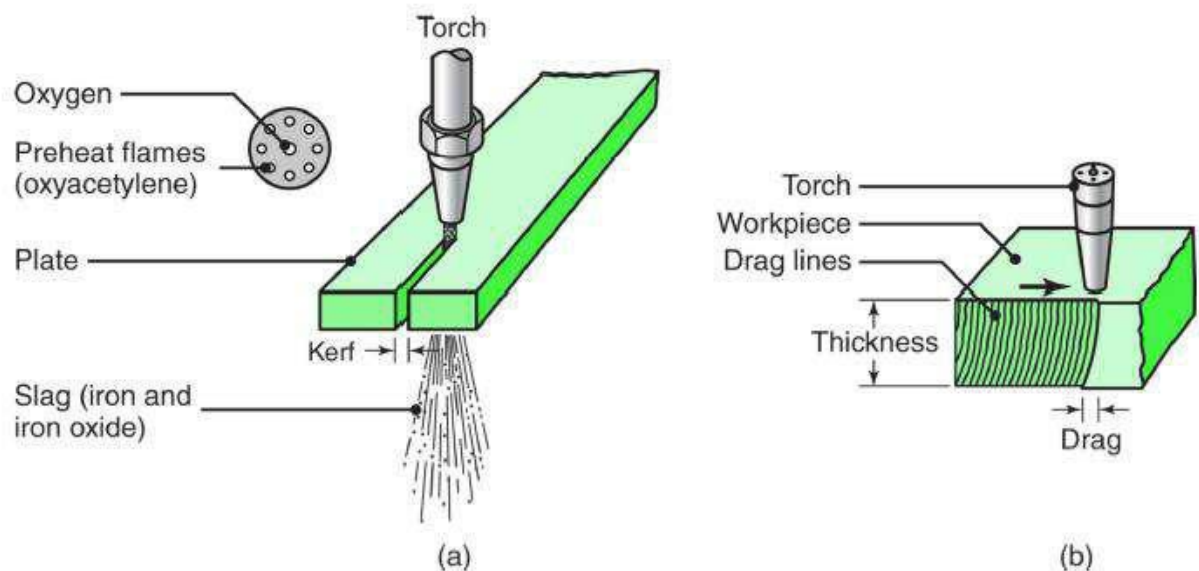

## Arc Cutting

- Based on same principles as arc-welding processes
- Can cut a variety of materials at high speeds
- Creates heat affected zone Air carbon-arc Cutting (CAC-A)
- Use carbon electrode
- Air jet blows away molten metal (no oxidation necessary)
- Need to contain blown molten metal
- Good for gouging & scarfing Noisy

## Plasma-arc Cutting (PAC)

- Produces highest temperatures
- For rapid cutting of non-ferrous & SS plates
- Higher productivity than OFC methods
- Produces good surface finish & narrow kerfs
- Most common manufacturing process utilizing programmable controllers Electron Beams and Lasers
- Can accurately cut many metals
- Narrow kerf

- Better surface finish than other thermal cutting processes

## Powder metallurgy – basics & applications

**Powder metallurgy** – science of producing metal powders and making finished /semifinished objects from mixed or alloyed powders with or without the addition of Non metallic constituents

**Steps in powder metallurgy:**

Powder production, Compaction, Sintering, & Secondary operations

**Powder production:**

Raw materials => Powder; Powders can be pure elements, pre-alloyed powders

Methods for making powders –

**Atomization:** Produces powders of both ferrous and non-ferrous powders like stainless steel, superalloys, Ti alloy powders;

**Reduction of compounds:** Production of iron, Cu, tungsten, molybdenum;

**Electrolysis:** for making Cu, iron, silver powders Powders along with additives are mixed using mixers Lubricants are added prior to mixing to facilitate easy ejection of compact and to minimize wear of tools; Waxes, metallic stearates, graphite etc.

**Compaction:** compaction is performed using dies machined to close tolerances. Dies are made of cemented carbide, die/tool steel; pressed using hydraulic or mechanical presses

The basic purpose of compaction is to obtain a green compact with sufficient strength to withstand further handling operations

The green compact is then taken for sintering Hot extrusion, hot pressing, hot isostatic pressing => consolidation at high temperatures

**Sintering:** Performed at controlled atmosphere to bond atoms metallurgically; Bonding occurs by diffusion of atoms; done at 70% of abs. melting point of materials It serves to consolidate the mechanically bonded powders into a coherent body having desired on service behavior Densification occurs during the process

and improvement in physical and mechanical properties are seen Furnaces – mesh belt furnaces (up to 1200C), walking beam, pusher type furnace, batch type furnaces are also used

Protective atmosphere: Nitrogen (widely used)

**Secondary operations:** Operations include repressing, grinding, plating can be done; They are used to ensure close dimensional tolerances, good surface finish, increase density, corrosion resistance etc.

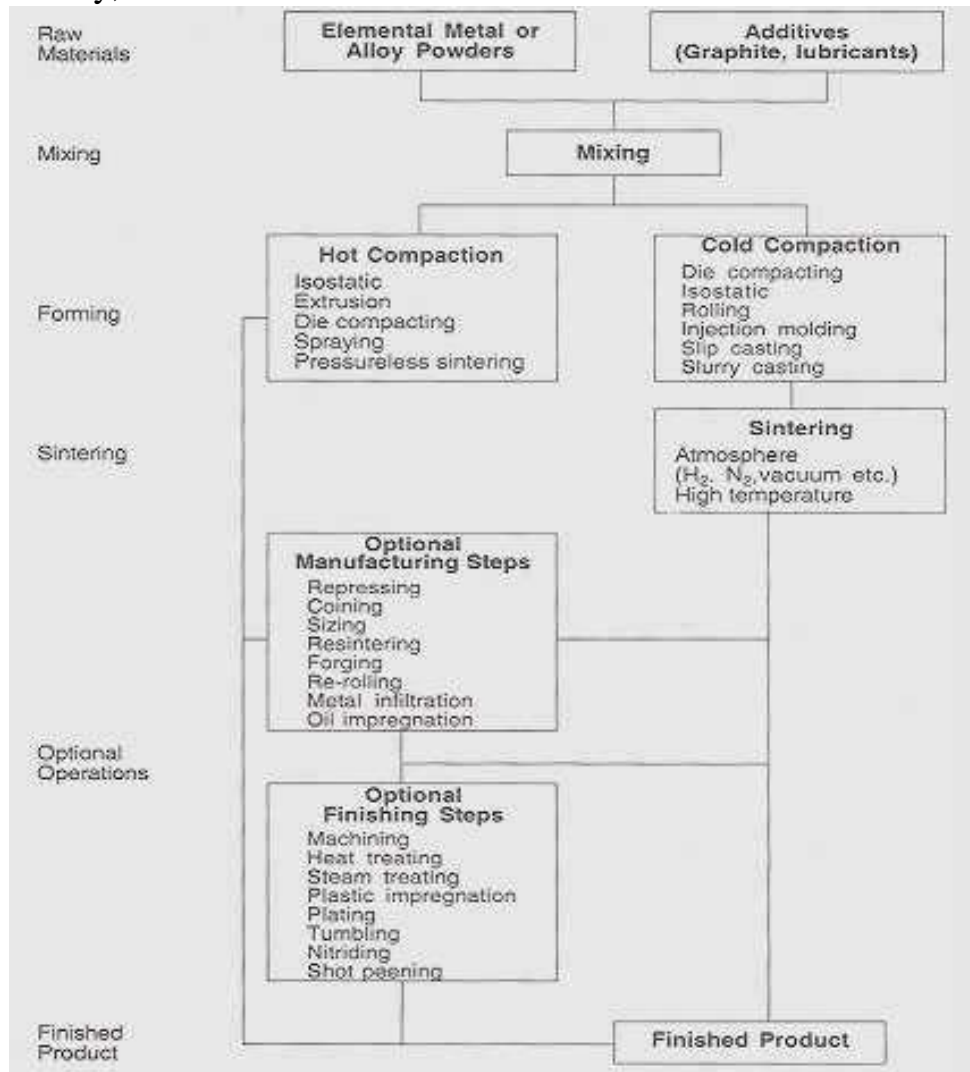

Flow chart for making P/M components

## Advantages & limitations

- Efficient material utilization
- Enables close dimensional tolerances – near net shape possible
- Good surface finish



- Manufacture of complex shapes possible
- Hard materials used to make components that are difficult to machine can be readily made – tungsten wires for incandescent lamps
- Environment friendly, energy efficient
- Suited for moderate to high volume component production
- Powders of uniform chemical composition => reflected in the finished part
- wide variety of materials => miscible, immiscible systems; refractory metals
- Parts with controlled porosity can be made
- High cost of powder material & tooling
- Less strong parts than wrought ones
- Less well known process

## **Module – III Plastic deformation of metals (14 Lectures)**

**Metal forming** is a general term for a large group that includes a wide variety of manufacturing processes. Metal forming processes are characteristic in that the metal being processed is plastically deformed to shape it into a desired geometry. In order to plastically deform a metal, a force must be applied that will exceed the yield strength of the material. When low amounts of stress are applied to a metal it will change its geometry slightly, in correspondence to the force that is exerted. Basically it will compress, stretch, and/or bend a small amount. The magnitude of the amount will be directly proportional to the force applied. Also the material will return to its original geometry once the force is released. Think of stretching a rubber band, then releasing it, and having it go back to its original shape. This is called elastic deformation. Once the stress on a metal increases past a certain point, it no longer deforms elastically, but starts to undergo plastic deformation. In plastic deformation, the geometric change in the material is no longer directly proportional to stress and geometric changes remain after the stress is released; meaning that the material does not recover its shape. The actual level of stress applied to a metal where elastic deformation turns to plastic deformation is called the proportional limit, and is often difficult to determine exactly. The .002 offset convention is usually used to determine the yield point, which is taken for practical purposes as the stress level where plastic deformation, (yielding), begins to occur. For more information on this topic review the mechanical properties of metals section in a material science text book.

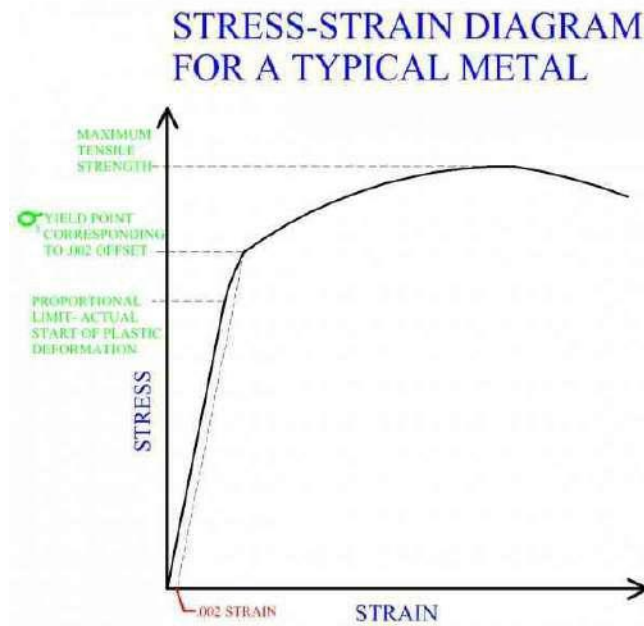

It can be seen by the stress-strain graph that once the yield point of a metal is reached and it is deforming plastically, higher levels of stress are needed to continue its deformation. The metal actually gets stronger, the more it is deformed plastically. This is called strain hardening or work hardening. As may be expected, strain hardening is a very important factor in metal forming processes. Strain hardening is often a problem that must be overcome, but many times strain hardening, when used correctly, is a vital part of the manufacturing process in the production of stronger parts.

### **Flow Stress**

During a metal forming operation, it is important to know the force and power that will be needed to accomplish the necessary deformation. The stress-strain graph shows us that the more a work piece is deformed plastically, the more stress is needed. The flow stress is the instantaneous value of the force necessary to continue the yielding and flow of the work material at any point during the process. Flow stress can be considered as a function of strain. The flow stress value can be used to analyze what is going on at any particular point in the metal forming process. The maximum flow stress may be a critical measurement in some metal forming operations, since it will specify the force and power requirements for the machinery to perform the process. The force needed at the maximum strain

of the material would have to be calculated in order to determine maximum flow stress.

For different types of metal forming processes, the flow stress analysis may be different. For a process like forging, the maximum flow stress value would be very important. However, for a process like extrusion, where the metal is continuously being deformed and the different stages of the metal's deformation are occurring simultaneously, it is of interest to analyze the mean flow stress value.

### Strain Rate

The strain rate for any particular manufacturing metal forming process is directly related to the speed at which deformation is occurring. A greater rate of deformation of the work piece will mean a higher strain rate. The specific process and the physical action of the equipment being used has a lot to do with strain rate. Strain rate will affect the amount of flow stress. The effect strain rate has on flow stress is dependent upon the metal and the temperature at which the metal is formed. The strain rate with relation to flow stress of a typical metal at different temperatures is shown in figure.

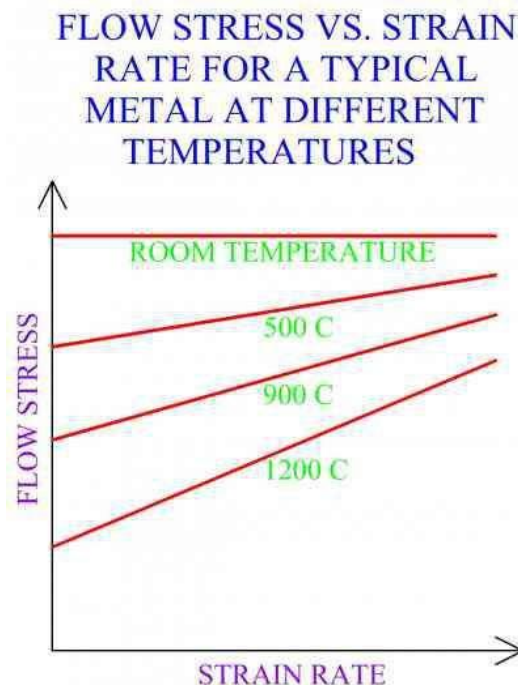

## **Effect Of Temperature In Metal Forming**

Properties of a metal change with an increase in temperature. Therefore, the metal will react differently to the same manufacturing operation if it is performed under different temperatures and the manufactured part may possess different properties. For these reasons, it is very important to understand the materials that we use in our manufacturing process. This involves knowing their behavior at various temperature ranges. In industrial metal forming manufacture, there are three basic temperature ranges at which the metal can be formed, cold working, warm working, and hot working.

### **Cold Working**

Cold working, (or cold forming), is a metal forming process that is carried out at room temperature or a little above it. In cold working, plastic deformation of the work causes strain hardening as discussed earlier. The yield point of a metal is also higher at the lower temperature range of cold forming. Hence, the force required to shape a part is greater in cold working than for warm working or hot working. At cold working temperatures, the ductility of a metal is limited, and only a certain amount of shape change may be produced. Surface preparation is important in cold forming. Fracture of the material can be a problem, limiting the amount of deformation possible. In fact, some metals will fracture from a small amount of cold forming and must be hot formed. One main disadvantage of this type of process is a decrease in the ductility of the part's material, but there are many advantages. The part will be stronger and harder due to strain hardening. Cold forming causes directional grain orientation, which can be controlled to produce desired directional strength properties. Also, work manufactured by cold forming can be created with more accurate geometric tolerances and a better surface finish. Since low temperature metal forming processes do not require the heating of the material, a large amount of energy can be saved and faster production is possible. Despite the higher force requirements, the total amount of energy expended is much lower in cold working than in hot working.

## **Warm Working**

Warm working, (or warm forming), is a metal forming process carried out above the temperature range of cold working, but below the recrystallization temperature of the metal. Warm working may be preferred over cold forming because it will reduce the force required to perform the operation. Also, the amount of annealing of the material that may have been necessary for the cold formed part may be less for warm working.

## **Hot Working**

Hot working, (or hot forming), is a metal forming process that is carried out at a temperature range that is higher than the recrystallization temperature of the metal being formed. The behavior of the metal is significantly altered, due to the fact that it is above its recrystallization temperature. Utilization of different qualities of the metal at this temperature is the characteristic of hot working.

Although many of these qualities continue to increase with increasing temperature, there are limiting factors that make overly high temperatures undesirable. During most metal forming processes the die is often cold or slightly heated. However, the metal stock for hot working will usually be at a higher temperature relative to the die. In the design of metal forming process, it is critical to consider the flow of metal during the forming of the work. Specific metal flow, for different forming processes, is discussed in latter sections under each specific process. For metal forming manufacturing, in general, the temperature gradient between the die and the work has a large effect on metal flow during the process. The metal nearer to the die surfaces will be cooler than the metal closer to the inside of the part, and cooler metal does not flow as easily. High temperature gradients, within the work, will cause greater differences in flow characteristics of different sections of the metal, these could be problematic. For example, metal flowing significantly faster at the center of the work compared to cooler metal near the die surfaces that is flowing slower, can cause part defects. Higher temperatures are harder to maintain throughout the metal forming process. Work cooling during the process can also result in more metal flow variations. Another consideration with hot forming manufacture, with regard to the temperature at which to form the part, is that the higher the temperature the more reactive the metal is likely to be. Also if a part for a hot working process is too hot then friction, caused during the process, may further increase heat to certain areas causing

melting, (not good), in localized sections of the work. In an industrial hot metal working operation, the optimum temperature should be determined according to the material and the specific manufacturing process.

When above its recrystallization temperature a metal has a reduced yield strength, also no strain hardening will occur as the material is plastically deformed. Shaping a metal at the hot working temperature range requires much less force and power than in cold working. Above its recrystallization temperature, a metal also possesses far greater ductility than at its cold worked temperature. The much greater ductility allows for massive shape changes that would not be possible in cold worked parts. The ability to perform these massive shape changes is a very important characteristic of these high temperature metal forming processes.

The work metal will recrystallize, after the process, as the part cools. In general, hot metal forming will close up vacancies and porosity in the metal, break up inclusions and eliminate them by distributing their material throughout the work piece, destroy old weaker cast grain structures and produce a wrought isotropic grain structure in the part. These high temperature forming processes do not strain harden or reduce the ductility of the formed material. Strain hardening of a part may or may not be wanted, depending upon the application. Qualities of hot forming that are considered disadvantageous are poorer surface finish, increased scale and oxides, decarburization, (steels), lower dimensional accuracy, and the need to heat parts. The heating of parts reduces tool life, results in a lower productivity, and a higher energy requirement than in cold working.

### **Selection of Temperature Range for a Metal Forming Operation**

Production at each of these temperature ranges has a different set of advantages and disadvantages. Sometimes, qualities that may be undesirable to one process may be desirable to another. Also, many times work will go through several processes. The goal is to design the manufacture of a part in such a way as to best utilize the different qualities to meet or enhance the specifications of the part. To produce a strong part with excellent surface finish, then a cold forming process could be a good choice. However, to produce a part with a high ductility a hot forming process may be best. Sometimes the advantages of both hot forming and cold forming are utilized when a part is manufactured by a series of processes. For example, hot working operations may first be performed on a work piece to achieve large amounts of shape change that would not be

possible with cold forming due to strain hardening and limited ductility. Then the last process that completes the manufacture of the part is a cold working operation. This process does not require a significant shape change, since most of the deformation was accomplished by the hot forming process. Having a cold forming process last will finish the shape change, while strengthening the part, giving a good surface finish and highly accurate tolerances.

### **Friction and Lubrication in Metal Forming**

Metal forming processes are characteristic of high pressures between two contacting surfaces. In hot forming operations, these high pressures are accompanied by extreme temperatures. Friction and die wear are a serious consideration in metal forming manufacturing. A certain amount of friction will be necessary for some metal forming processes, but excessive friction is always undesirable. Friction increases the amount of force required to perform an operation, causes wear on tooling, and can affect metal flow, creating defects in the work.

Where friction is involved, lubricants can usually help. For some metal forming processes and materials no lubrication is used, but for many lubrication is applied to contacting surfaces to reduce friction forces. Lubricants used in industry are different depending upon the type of metal forming process, the temperature at which the operation occurs, and the type of material formed. Lubricants should be effective and not produce any toxic fumes. Lubricants used in manufacturing industry for metal forming processes include, vegetable and mineral oils, soaps, graphite dispensed in grease, water based solutions, solid polymers, wax, and molten glass.

### **Different Types of Metal Forming Processes**

Metal forming processes can be classified under two major groups. Bulk deformation processes and sheet metal working processes. Bulk deformation is characteristic in that the work formed has a low surface area to volume ratio. In sheet metal working, the metal being processed will have a high surface area to volume ratio. The following is a brief overview of the major metal forming processes that will be covered in detail later.

#### **Bulk Deformation**

**Rolling:** Rolling is a metal forming process that deforms the work by the use of rolls. Rolling processes include flat rolling, shape rolling, ring rolling,



thread rolling, gear rolling, and the production of seamless tube and pipe by rotary tube piercing or roll piercing.

**Forging:** Forging is characteristic in the use of dies to compress and shape a work piece. The die may be flat or may contain an impression of a certain geometry.

**Extrusion:** Extrusion involves forming by forcing metal through a die opening, producing work of variable length and constant cross section.

**Drawing:** Drawing is similar to extrusion, in that a length of metal is made to flow through a die opening and forming is done over its cross section. The difference between drawing and extrusion is the application of force to the work piece. In extrusion the work is pushed through the die opening, in drawing the work is pulled through the die opening.

### **Sheet Metal Working**

**Shearing:** Shearing is the cutting of the work piece, this would include punching holes. Technically shearing does not involve shaping by plastic deformation, but it is a critical process in sheet metal working operations and should be understood along with metal forming processes.

**Bending:** Bending involves the deformation of the work by way of bending about a certain axis.

**Deep Drawing:** Deep drawing is a metal forming process in which a flat piece of plate or sheet is forced into a die cavity to take a shape, such as a cup.

### **Optimization Strategies for Metal Forming Processes**

Cost saving and product improvement have always been important goals in the metal forming industry. To achieve these goals, metal forming processes need to be optimised. During the last decades, simulation software based on the Finite Element Method (FEM) has significantly contributed to designing feasible processes more easily. More recently, the possibility of coupling FEM to mathematical optimisation techniques is offering a very promising opportunity to design optimal metal forming processes instead of just feasible ones. The developed structured methodology for modelling optimisation problems in metal forming is based on the generally applicable Product Development Cycle. This Product Development Cycle has been related to metal parts and their forming processes and subsequently to the modelling of optimisation problems, i.e.

defining objective function, constraints and design variables. In the modelling methodology yields a mathematically formulated optimisation model for a variety of optimisation problems, products and metal forming processes. Solving the modelled optimisation problem is done in two stages: screening and optimising using an algorithm. The number of design variables may also be large, which makes solving the optimisation problem prohibitively time consuming. Screening techniques based on Mixed Array Design of Experiment (DOE) plans and Mean response plots have been developed to remove discrete design variables by selecting the best level of the discrete variable. Resolution III fractional factorial DOE plans, ANalysis Of VAriance, and Pareto and Effect plots assist in reducing the number of continuous design variables. The implemented screening techniques reduce the size of the optimisation problem in order to solve it efficiently in a second solving stage: optimisation. For optimisation, a Sequential Approximate Optimisation (SAO) algorithm has been developed. Running the corresponding FEM simulations yields response measurements through which metamodels can be fitted using Response Surface Methodology (RSM) and Kriging metamodeling techniques. These metamodels are subsequently optimised very quickly using a global multistart SQP algorithm. Several sequential improvement strategies have been implemented to efficiently improve the accuracy of the obtained optimum. Process robustness and reliability play an important role for industrial metal forming processes. To this end, the deterministic optimisation strategy described above has been extended to a robust optimisation strategy. In addition to deterministic control variables, noise variables are included as normally distributed inputs. Also, objective function and constraints are consequently stochastic quantities having a certain distribution. The screening techniques developed for deterministic optimisation can be applied to robust optimisation problems without any adaptations. The SAO algorithm has been adapted to efficiently optimise response distributions rather than response values. The deterministic and robust optimisation strategies have been applied to several industrial metal forming processes. These applications comprise different products and processes (a forged spindle and gear, a deep drawn automotive part, a hydro-formed automotive part, and a deep drawn small cup). It can be concluded from these applications that both the deterministic and robust optimisation strategies are generally applicable to a wide variety of metal

forming problems, products and processes. Comparisons between the deterministic and robust optimisation strategies demonstrated that taking into account process robustness and reliability during optimisation is an important issue for optimising industrial metal forming processes. Next to general applicability, efficiency is a second requirement for the optimisation strategy. Screening plays an important role in reducing the problem size at the expense of a limited number of FEM simulations only. The efficiency of the SAO algorithm has been compared to that of other optimisation algorithms by application to two forging processes: the SAO algorithm yielded better results using less FEM simulations. Additionally, the optimisation strategy solved the three complicated industrial optimisation problems in less than 100 FEM simulations each. The screening techniques, the SAO algorithm and robust extension allow for running FEM simulations in parallel, which reduces the calculation time.

## Rolling

Rolling is one of the most important industrial metal forming operations. Hot Rolling is employed for breaking the ingots down into wrought products such as into blooms and billets, which are subsequently rolled to other products like plates, sheets etc. Rolling is the plastic deformation of materials caused by compressive force applied through a set of rolls. The cross section of the work piece is reduced by the process. The material gets squeezed between a pair of rolls, as a result of which the thickness gets reduced and the length gets increased. Mostly, rolling is done at high temperature, called hot rolling because of requirement of large deformations. Hot rolling results in residual stress-free product. However, scaling is a major problem, due to which dimensional accuracy is not maintained. Cold rolling of sheets, foils etc is gaining importance, due to high accuracy and lack of oxide scaling. Cold rolling also strengthens the product due to work hardening. Steel ingot is the cast metal with porosity and blowholes. The ingot is soaked at the hot rolling temperature of 1200°C and then rolled into blooms or billets or slabs. Bloom is has a square cross section, with area more than 230 cm<sup>2</sup> . A slab, also from ingot, has rectangular cross-section, with area of at least 100 cm<sup>2</sup> and width at least three times the thickness. A billet is rolled out of bloom, has at least 40 mm X 40 mm cross-section. Blooms are used for rolling structural products

such as I-sections, channels, rails etc. Billets are rolled into bars, rods. Bars and rods are raw materials for extrusion, drawing, forging, machining etc. Slabs are meant for rolling sheets, strips, plates etc.

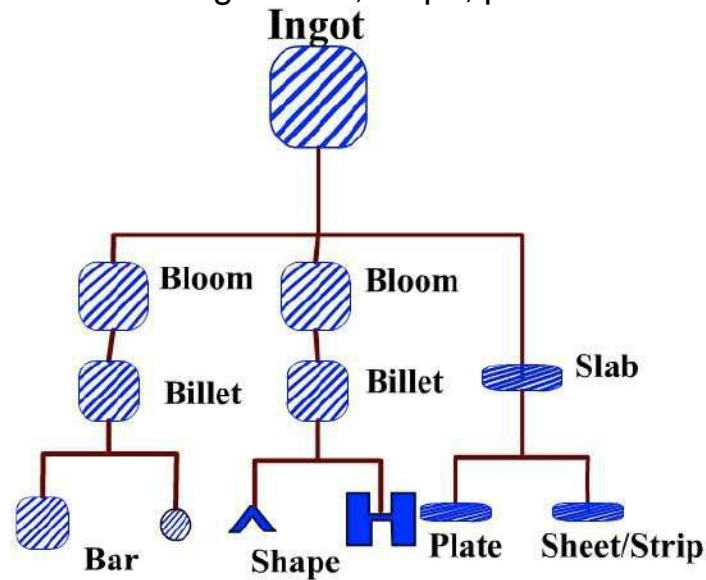

Rolling sequence for fabrication of bars, shapes and flat products from blooms, billets and slabs

Flow diagram showing Rolling of different products

Plates have thickness greater than 6 mm whereas strips and sheets have less than 6 mm thickness.

Sheets have greater width and strip has lower width – less than 600 mm.

### Rolling mills:

Rolling mill consists of rolls, bearings to support the rolls, gear box, motor, speed control devices, hydraulic systems etc.

The basic type of rolling mill is two high rolling mill. In this mill, two opposing rolls are used.

The direction of rotation of the rolls can be changed in case of reversing mills, so that the work can be fed into the rolls from either direction. Such mills increase the productivity.

Non reversing mills have rolls rotating in same direction. Therefore, the work piece cannot be fed from the other side. Typical roll diameters may be 1.4 m.

A three high rolling mill has three rolls. First rolling in one direction takes place along one direction. Next the work is reversed in direction and fed through the next pair of roll. This improves the productivity.

Rolling power is directly proportional to roll diameter. Smaller dia rolls can therefore reduce power input. Strength of small diameter rolls are poor. Therefore, rolls may bend. As a result, larger dia backup rolls are used for supporting the smaller rolls. Four high rolling mill is one such mill.

Thin sections can be rolled using smaller diameter rolls. Cluster mill and Sendzimir mill are used for rolling thin strips of high strength materials and foils [0.0025 mm thick].

The work roll in these mills may be as small as 6 mm diameter – made of tungsten carbide. Several rolling mills arranged in succession so as to increase productivity is called rolling stand.

In such arrangement, an uncoiler and windup reels are used. They help in exerting back tension and front tension.

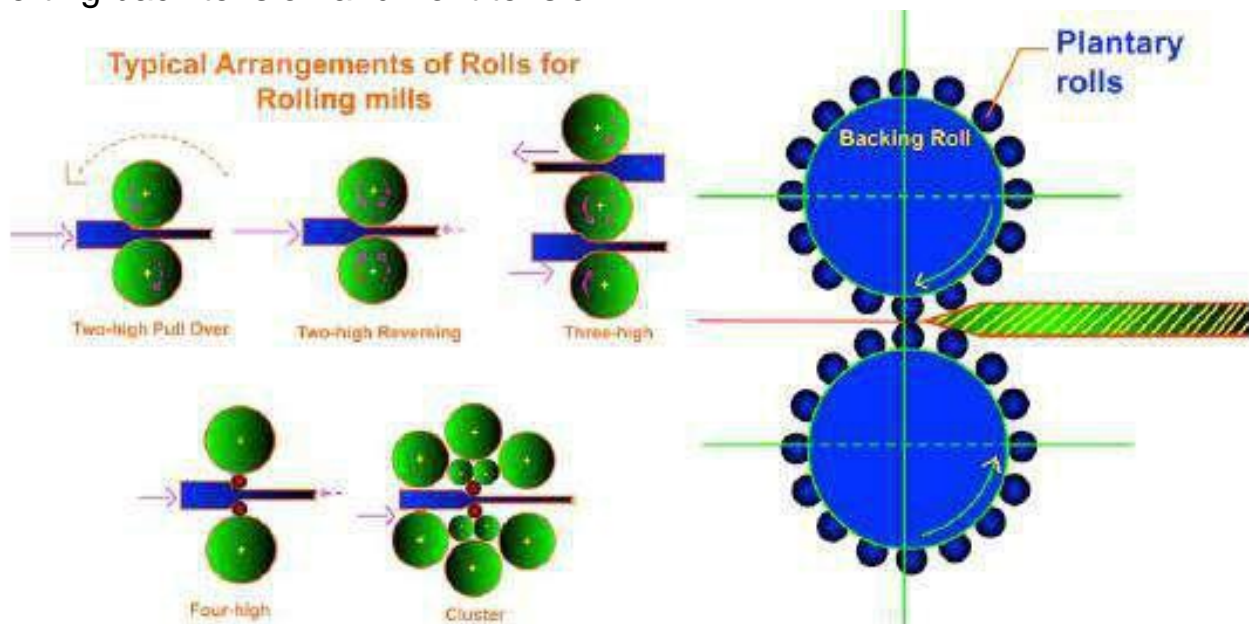

Rolling mills

Planetary mill has a pair of large heavy rolls, surrounded by a number of smaller rolls around their circumference. In this mill, a slab can be reduced to strip directly in one pass. Feeder rolls may be needed in order to feed the work piece into the rolls.

Merchant mill is specifically used for rolling bars.

Hot rolling is usually done with two high reversing mill in order to breakdown ingots into blooms and billets. For increased productivity, universal mill has two vertical rolls which can control the width of the work simultaneously.

Non ferrous materials are cold rolled into sheets from hot rolled strips. Four high tandem mills are generally used for aluminium and copper alloys. In order to achieve upto 90% reduction in thickness in cold rolling, a series of rolling mills may be used to share the total reduction.

One important application of cold rolling is the removal of yield point from mild steel sheets using skin pass rolling [temper rolling]. In this the steel sheet is given a light reduction of 0.5 to 1.5% . Such a process eliminates yield point elongation. If yield elongation of steel occurs during sheet metal operation, such as deep drawing, the surface of the sheet metal becomes rough due to formation of Luder bands, also called stretcher strains. Flatness of rolled sheets can be increased by roller leveling. In this process, the sheet is passed between a pair of rolls which are driven by individual motors and are slightly offset.

Rolls should have high stiffness, hardness and strength. Cast iron, cast steel and forged steel are also used as rolls.

### **Grain structure in rolling:**

When the wrought or cast product gets hot rolled, the grain structure, which is coarse grained, becomes finer in size, but elongated along the direction of rolling. This type of textured grain structure results in directional property [anisotropy] for the rolled product. In order to refine the grains, heat treatment is performed immediately after rolling, which results in recrystallization after rolling.

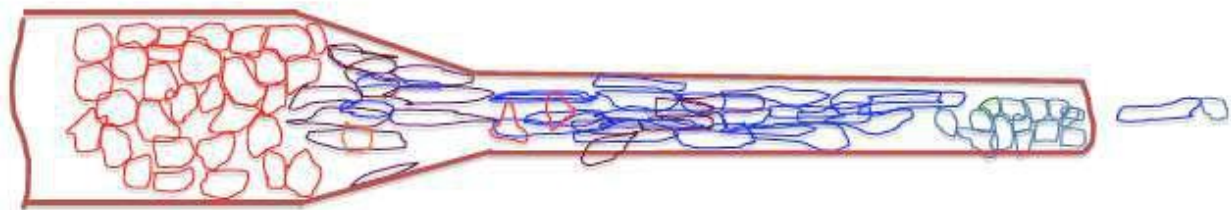

Variation of grain structure, size during longitudinal rolling

### **Special rolling processes:**

Bulk deformation processes such as shape rolling, thread rolling, roll piercing, ring rolling also use pair of rolls. Some of such important processes are discussed briefly below: Thread and gear rolling:

Threads on cylindrical work pieces can be cold formed using a pair of flat dies or cylindrical rolls under reciprocating or rotary motion. Screws, bolts and other externally threaded fasteners are produced by thread rolling. Thread rolling is a high productivity process involving no loss of material.

Due to grain flow in thread rolling strength is increased. Surface finish of rolled threads is very good. Gears can also be produced by the thread rolling process. Compressive stresses introduced during the process is favourable for fatigue applications. Auto power transmission gears are made by thread rolling. Shape rolling: Structural sections such as I-sections, rails, channels can be rolled using set of shaped rolls. Blooms are usually taken as raw materials for shape rolling. Multiple steps are required in shape rolling. Ring rolling: Smaller diameter, thicker ring can be enlarged to larger diameter, thinner section by ring rolling. In this process, two circular rolls, one of which is idler roll and the other is driven roll are used. A pair of edging rollers are used for maintaining the height constant. The ring is rotated and the rings are moved closer to each other, thereby reducing the thickness of ring and increasing its diameter. Rings of different cross-sections can be produced. The major merits of this process are high productivity, material saving, dimensional accuracy and grain flow which is advantageous. Large rings for turbines, roller bearing races, flanges and rings for pipes are some of the applications of this process.

**Rolling defects:** Mill spring is a defect in which the rolled sheet is thicker than the required thickness because, the rolls get deflected by high rolling forces. Elastic deformation of the mill takes place. If we use stiffer rolls, namely roll material of high stiffness or elastic constant, we could avoid mill spring. Normally elastic constant for mills may range from 1 to 4 GNm<sup>-1</sup>.

Roll elastic deformation may result in uneven sheet thickness across. Roll material should have high elastic modulus for reducing the roll deformation. For producing very thin gage sheets like foils, small diameter rolls are used. They are supported with larger rolls. We can say the minimum thickness of rolled sheets achieved is directly proportional to roll radius, friction, flow stress.

Flatness of rolled sheets depends on the roll deflection. Sheets become wavy as roll deflection occurs.

If rolls are elastically deflected, the rolled sheets become thin along the edge, whereas at centre, the thickness is higher. Similarly, deflected rolls result in longer edges than the centre. Edges of the sheet elongate more than the centre. Due to continuity of the sheet, we could say  $h_f1$   $h_f2$   $h_o$  Strip thickness that the centre is subjected to tension, while edges are subjected to compression. This leads to waviness along edges. Along the centre zipper cracks occur due to high tensile stress there. Cambering of

rolls can prevent such defects. However, one camber works out only for a particular roll force.

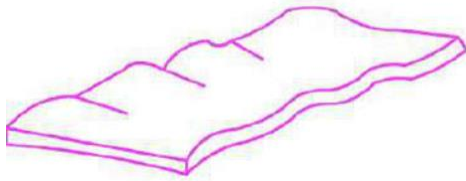

Wavy edge

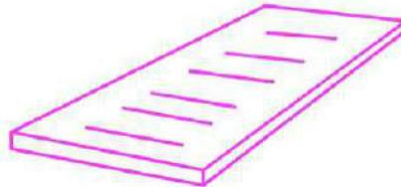

Zipper cracks

In order to correct roll deflection for a range of rolling conditions, hydraulic jacks are used, which control the elastic deformation of rolls according to requirement.



Centre crack

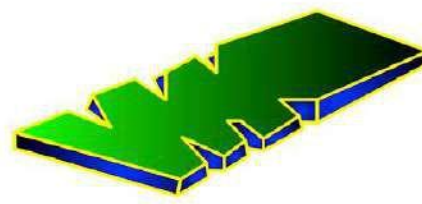

Edge cracks

If rolls have excess convexity then the center of the sheet metal will have more elongation than the edges. This leads to a defect called centre buckle. Edge defect due to heavy reduction Small thickness sheets are more sensitive to roll gap defects leading to greater defects. Thin strips are more likely to undergo waviness or buckling. These defects are corrected by doing roller leveling or stretch leveling under tension. Stretch leveling is carried out between roller leveler rolls. During rolling the sheet will have a tendency to deform in lateral direction. Friction is high at the centre. Therefore, spread is the least at the centre. This leads to rounding of ends of the sheet. The edges of the sheet are subjected to tensile deformation.

This leads to edge cracks. If the center of the sheet is severely restrained and subjected to excess tensile stress, center split may happen. Non-homogeneous material deformation across the thickness leads to high secondary tensile stress along edge. This leads to edge cracks. Secondary tensile stresses are due to bulging of free surface. Edge cracks can be avoided by using edge rolls. Due to non homogeneous



flow of material across the thickness of the sheet, another defect called allegating occurs. This is due to the fact that the surface is subjected to tensile deformation and centre to compressive deformation. This is because greater spread of material occurs at center.

### Rolling force in hot rolling:

Material flow in hot rolling is less homogeneous. Strain rate also affects the flow stress of the material. Further, friction conditions are rather unpredictable. Friction coefficient in hot rolling may be high – ranges from 0.2 to 0.7. Strain rate in hot rolling can be found out from the expression:

$$\dot{\epsilon} = \ln\left(\frac{h_0}{h_f}\right) / \text{time} \quad \text{-----} \quad 5.3$$

Time can be written as:  $L/V$ , where  $V$  is velocity of roll,  $L$  is projected arc length.

$$\text{Therefore, } \dot{\epsilon} = (V/L)\ln\left(\frac{h_0}{h_f}\right) = (V/\sqrt{R\Delta h})\ln\left(\frac{h_0}{h_f}\right) \quad \text{-----} \quad 5.4$$

From flow curve we can determine the flow stress for the corresponding strain rate.

### Total roll force:

Roll force is equal to roll pressure multiplied by area of contact between roll and work.

$$F = \int_0^{\theta_n} p w R d\theta + \int_{\theta_n}^{\alpha} p w R d\theta \quad \text{-----} \quad 5.5$$

If friction is ignored, we can write an approximate expression for roll force as:

$$F = L w \bar{Y}' \quad \text{-----} \quad 5.6$$

With friction:

$$F = L w \bar{Y}' \left(1 + \frac{\mu L}{2h_{av}}\right) \quad \text{-----} \quad 5.7$$

Where,  $h_{av}$  is given by:  $(h_0 + h_f)/2$

### Roll torque and power:

Roll torque can be estimated from the rolling force. Torque is equal to force multiplied by the radius at which the force acts.

We can assume that the roll force is acting perpendicular to the strip at a radius equal to one half of the projected arc length of contact.

For each roll, the torque is:  $T = FL/2$

Roll power is given by:

$$\text{Power} = 2\pi NT \text{ -----5.8}$$

Torque can be more accurately determined from:

$$T = \int_0^{\theta_n} p w R^2 d\theta - \int_{\theta_n}^{\alpha} p w R^2 d\theta \text{ -----5.9}$$

Here the minus sign is due to the fact that the friction force acts against the rolling direction beyond the neutral section. Total roll torque consists of the rolling torque plus the torque required to overcome friction in roll bearings plus torque at motor shaft plus torque for overcoming friction in transmission system.

Roll power is applied in order to deform the work material, to overcome friction in rotating parts etc.

**Forging** is the process of forming and shaping metals through the use of hammering, pressing or rolling. The process begins with starting stock, usually a cast ingot (or a "cogged" billet which has already been forged from a cast ingot), which is heated to its plastic deformation temperature, then upset or "kneaded" between dies to the desired shape and size.

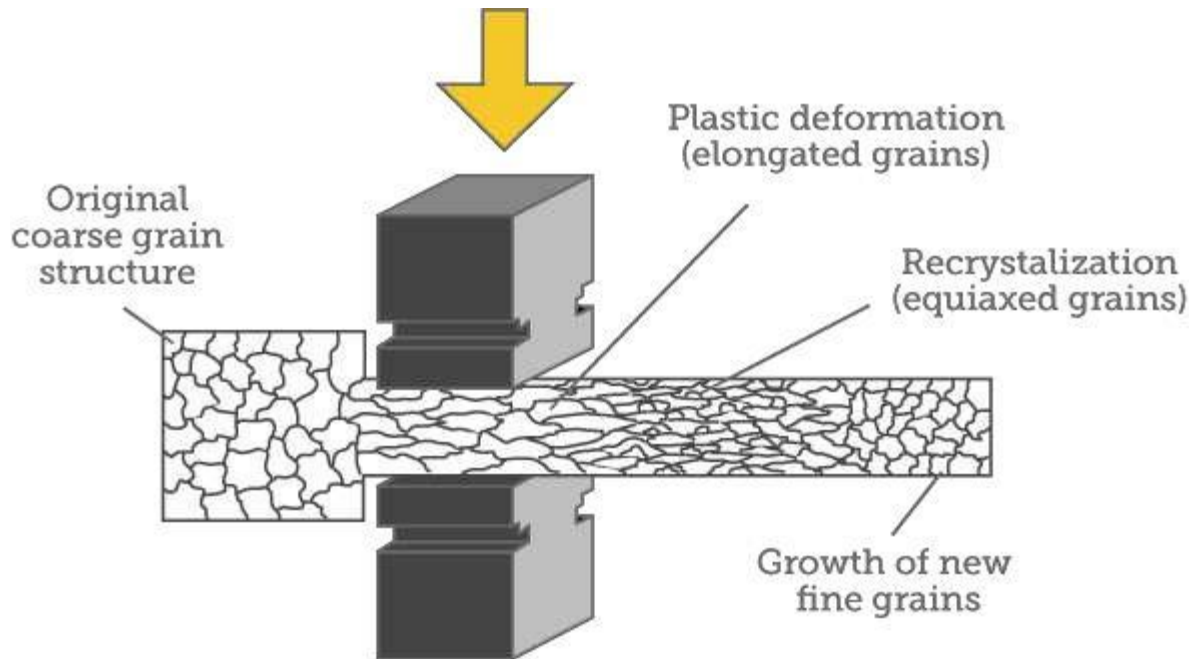

**How the open die forging process affects the crystal structure.**

### **Type of forging**

1. smith forging
2. drop forging
3. press forging
4. machine forging

#### **1: Smith forging**

This is the traditional forging operation done openly or in-openly dies by the village black smith or modern shop floor by manual hammering or by the power hammer. The process involves heating the stock in the black smith hearth and then beating it over the anvil. To get the desire shape the operator has to manipulate the component in between the blows.

The types of operation available are fullering, flatterring, bending , upsetting and swaging.

#### **2: Drop forging**

This is the operation done in closed impression dies by means drop hammer here the force for shaping the component is applied in a series of blows.

Drop forging utilizes a closed impression die to obtain the desired shape of the component, the shaping is done by the repeated hammering given to the material in the die cavity. The equipment used for delivering blows are called drop hammers. The drop forging die consists of two halves. The lower half of the die is fixed to the anvil of the machine, while the upper half is fixed to the ram. The heated stock is kept in the lower die, while the ram delivers 4-5 blows on the metal, spreading and completely filling the die cavity. When the two die halves close, the component is formed. The typical products obtained in drop forging are cranks, crank shaft, connecting rods, wrench, crane hooks etc. The types of operations are fullering, edging, bending, blocking, finishing and trimming etc.

### **3: Press forging**

Similar to the drop forging, the press forging is also done in closed impression dies with the expectation that the force is continuous squeezing type applied by the hydraulic press. Press forging dies are similar to drop forging dies as also the process in press forging, the metal is shaped not by means of a series of blows as in drop forging, but by means of a single continuous squeezing action. This squeezing is obtained by means of hydraulic presses. Because of the continuous action of hydraulic presses, the material gets uniformly deformed through out its entire depth, the press forging dies with the various impressions, such as fuller, bender and finisher impressions properly arranged.

### **4: Machine forging:**

Unlike the press or drop forging where the material is drawn out, in machine forging the material is only upset to get the desired shape. As it involves the upsetting operation some time it is simply called as upset forging. Originally this was developed for making bolt heads in a continuous fashion, but now there are fairly large numbers of diverse uses of this process:

Because of the beneficial grain flow obtained from upsetting. It is used for making gears, blanks, shafts, axles, and similar parts. Upsetting machines called up setters are generally horizontal acting. The die set consists of die and corresponding punch or a heading tool. The die consists of two parts, one called the stationary gripper die which is fixed to the machine frame and the other movable gripper die which moves along with the die slide of the up setter. The stock is held then between these two gripper dies.

The upset forging cycle start with the, movable die sliding against the stationary die to grip the stock. The two dies when in closed position form the necessary die cavity then the heading tool advance against the stock and upset it to completely filled to the die cavity.

Having completed the upsetting the heading tool moves back to its back position. Then the movable gripper die releases the stock by sliding backward. Similar to drop forging it is not possible to get the final shape in a single pass in machine forging also. Therefore the operation is carried out in number of stages. The die cavities is required for the various operations are all arrange vertically on the gripper dies. The stock is the move from stage one to another in proper sequence till the final forging is ready. A heading tool each for every upsetting stage is arranged on the heading slide of the upsetting machine.

A typical upsetting die and heading tool is shown:

**Up Setting Die  
and Heading  
Tool:-**

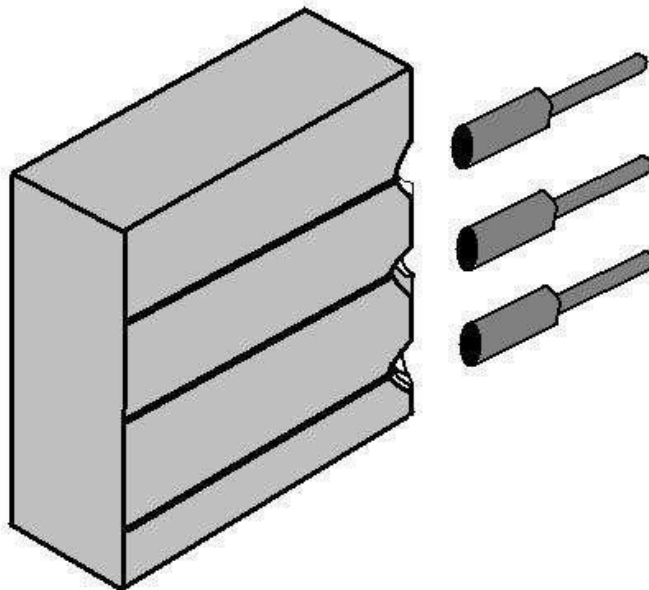

Forging defects:

Though forging process give generally prior quality product compared other manufacturing processes. There are some defects that are lightly to come a proper care is not taken in forging process design.

A brief description of such defects and their remedial method is given below.

(A): Unfilled Section:

In this some section of the die cavity are not completely filled by the flowing metal. The causes of this defects are improper design of the forging die or using forging techniques.

(B): Cold Shut:

This appears as a small cracks at the corners of the forging. This is caused manely by the improper design of die. Where in the corner and the fillet radie are small as a result of which metal does not flow properly into the corner and the ends up as a cold shut. (C): Scale Pits:

This is seen as irregular depurations on the surface of the forging. This is primarily caused because of improper cleaning of the stock used for forging. The oxide and scale gets embedded into the finish forging surface. When the forging is cleaned by pickling, these are seen as depurations on the forging surface.

(D): Die Shift:

This is caused by the miss alignment of the die halve, making the two halve of the forging to be improper shape.

(E): Flakes:

These are basically internal ruptures caused by the improper cooling of the large forging. Rapid cooling causes the exterior to cool quickly causing internal fractures. This can be remedied by following proper cooling practices.

(F): Improper Grain Flow:

This is caused by the improper design of the die, which makes the flow of the metal not flowing the final interred direction.

## Module IV Extrusion and sheet metal works

**Extrusion** is a method of forming in which metals or plastics are forced through a die or series of dies, resulting in a specific shape of constant cross section. With the proper tooling, extrusions may be tapered or stepped. Extrusions can be either very thick in cross section or very thin and be either solid or hollow. The extruded stock, which can be 100 feet in length or longer, is then cut to a convenient stock size and used as specific products, assembly components, or as raw stock material for further processing. Extrusion size is expressed as a circle size which relates to the smallest circle diameter which can enclose an extrusion's cross section.

### Metal Extrusion

Metal extrusion processes may be performed hot, warm, or cold. Each method has its own unique operating parameters.

**Hot Extrusion** uses heated feedstock, called a billet, that ranges in temperature from 200° to 2,300° Fahrenheit, or 90° to 1,260° Celsius depending on the material. Aluminum is the most common hot extruded material, with billet temperatures ranging from 575° to 1,100° Fahrenheit, or 300° to 600° Celsius.

Hot extrusion is always performed at temperatures much higher than the recrystallization temperature of the material to be extruded. The heated billet is confined in a container, force is applied and the billet is extruded through a die or dies. Hot extrusion is used to produce close tolerance dimensions as well as smooth, fine surfaces. Additionally, and depending on the metal used, improved microstructures are obtained. The process is also very economical in that most of the metal extruded is usable.

The primary type of hot extrusion is direct, or forward, extrusion. Direct extrusion is commonly performed in horizontal hydraulic presses. The heated billet is loaded into a thick-walled container from which it is pushed through the extrusion die by a ram. Between the ram and the billet is an intermediate dummy block. Lubrication is used to reduce friction along the billet length and its container. In operation, force increases rapidly as the billet is upset to fill the container, then increases further as breakthrough force before extrusion begins. Upon breakthrough, the force declines as billet length decreases until a minimum force is reached. as the billet thins, the force rapidly rises again to continue metal flow radially toward the die opening.

Hot extrusion presses are rated in force capacity which relates to available ram pressure on the billet. Ram pressure requirements are based upon:

- Billet material and temper
- Cross section dimensions
- Complexity of the extrusion
- Extrusion length and temperature

Another factor in determining ram force requirements is the extrusion ratio. This is determined by dividing the cross sectional area of the container liner by the cross sectional area of the die openings.

Warm extrusion refers to the extruding of feedstock or billet while it is above room temperature, but well below the recrystallization temperatures used in hot extrusion. Cold extrusion refers to extrusion at room temperatures. Because the feedstock is at lower temperatures, no micro-structural changes occur during processing. Warm and cold extrusion processes increase the strength and hardness of the finished extrusion. Reduced heat also lowers pollution concerns and eliminates costly high temperature tooling. While virtually all metals may be warm and cold extruded, those having the highest ductility are more suited for processing. Warm and cold extrusion processes are commonly integrated into continuous and semi-continuous manufacturing operations, with the three primary methods including:

- Indirect extrusion•
- Combination extrusion•
- Impact extrusion

Indirect extrusion, which is also called backward extrusion, is used to produce hollow shapes with the inside diameter defined by the male punch and the outside diameter controlled by the female die. Combination extrusion combines various types of extruding including direct and indirect methods to produce more complex shapes. Impact extrusion is similar to the other extrusion methods described, but is a much faster process. Using shorter strokes and shallower dies, punch impact moves the feedstock slug either up, down, or in both directions at once, without being completely confined by either the punch or die walls. Ductile and low melting point metals such as tin, aluminum, zinc, and copper are well suited for impact extruding.



### Types of extrusion:

Extrusion ratio: It is the ratio of area of cross-section of the billet to the area of cross-section of the extrude.  $R = A_o/A_f$

Another parameter used in extrusion is shape factor, ratio of perimeter to the cross-section of the part. An extruded rod has the lowest shape factor.

Extrusion is classified in general into four types. They are:

- Direct extrusion,
- indirect extrusion,
- impact extrusion and
- hydrostatic extrusion.

In extrusion process, the billet is placed in a container, pushed through the die opening using a ram and dummy block. Both ram and billet move.

#### Direct extrusion:

Direct extrusion, also called forward extrusion, is a process in which the billet moves along the same direction as the ram and punch do. Sliding of billet is against stationary container wall. Friction between the container and billet is high. As a result, greater forces are required. A dummy block of slightly lower diameter than the billet diameter is used in order to prevent oxidation of the billet in hot extrusion. Hollow sections like tubes can be extruded by direct method, by using hollow billet and a mandrel attached to the dummy block.

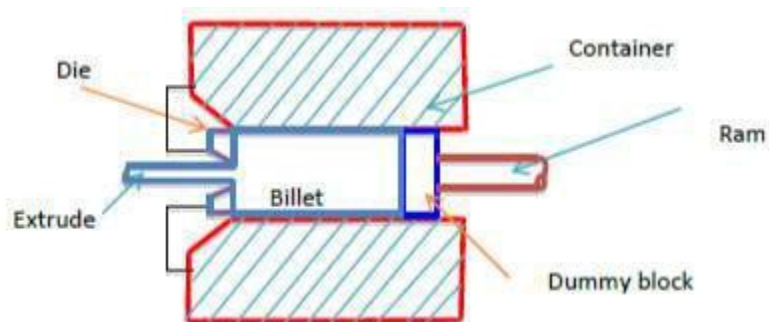

Direct Extrusion

#### Indirect extrusion

Indirect extrusion (backward extrusion) is a process in which punch moves opposite to that of the billet. Here there is no relative motion between

container and billet. Hence, there is less friction and hence reduced forces are required for indirect extrusion. For extruding solid pieces, hollow punch is required. In hollow extrusion, the material gets forced through the annular space between the solid punch and the container. The variation of extrusion pressure in indirect extrusion is shown above. As seen, extrusion pressure for indirect extrusion is lower than that for direct extrusion. Many components are manufactured by combining direct and indirect extrusions. Indirect extrusion can not be used for extruding long extrudes.

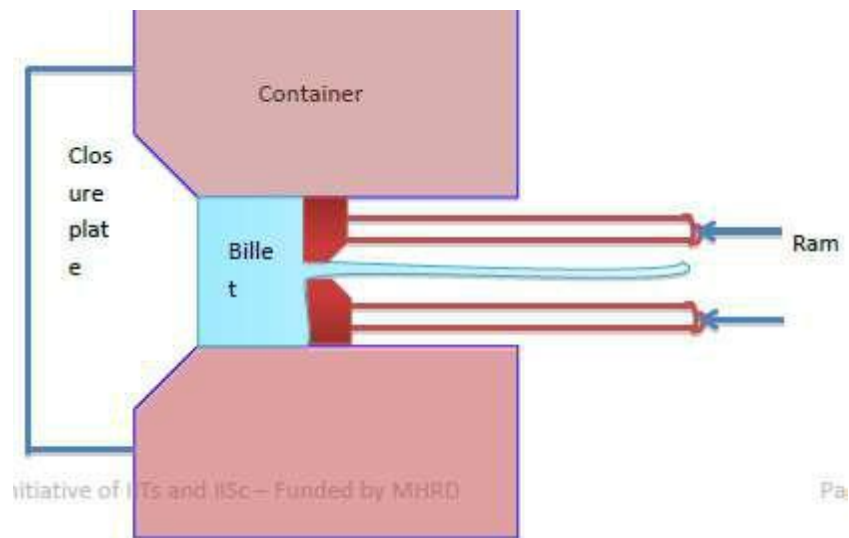

Indirect Extrusion

### Hydrostatic extrusion:

In hydrostatic extrusion the container is filled with a fluid. Extrusion pressure is transmitted through the fluid to the billet. Friction is eliminated in this process because of there is no contact between billet and container wall. Brittle materials can be extruded by this process. Highly brittle materials can be extruded into a pressure chamber. Greater reductions are possible by this method. Pressure involved in the process may be as high as 1700 MPa. Pressure is limited by the strength of the container, punch and die materials. Vegetable oils such as castor oil are used. Normally this process is carried out at room temperature. A couple of disadvantages of the process are: leakage of pressurized oil and uncontrolled speed of extrusion at exit, due to release of stored energy by the oil. This may result in shock in the machinery. This problem is overcome by making the punch come into contact with the billet and reducing the quantity of oil through less clearance between billet and container. Hydrostatic extrusion is

employed for making aluminium or copper wires-especially for reducing their diameters. Ceramics can be extruded by this process. Cladding is another application of the process. Extrusion ratios from 20 (for steels) to as high as 200 (for aluminium) can be achieved in this process.

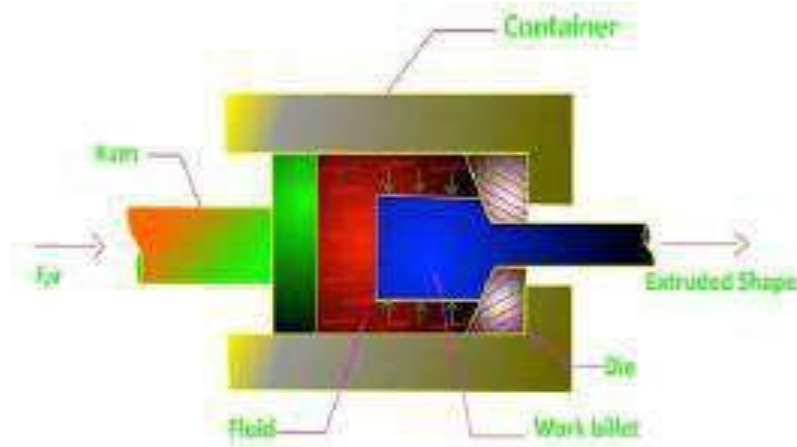

Hydrostatic Extrusion

**Impact extrusion:** Hollow sections such as cups, toothpaste containers are made by impact extrusion. It is a variation of indirect extrusion. The punch is made to strike the slug at high speed by impact load. Tubes of small wall thickness can be produced. Usually metals like copper, aluminium, lead are impact extruded.

**Tube extrusion:**

Employing hollow billet and a mandrel at the end of the ram, hollow sections such as tubes can be extruded to closer tolerances. The mandrel extends upto the entrance of the die. Clearance between the mandrel and die wall decides the wall thickness of the tube. The mandrel is made to travel alongwith the ram in order to make concentric tubes by extrusion.

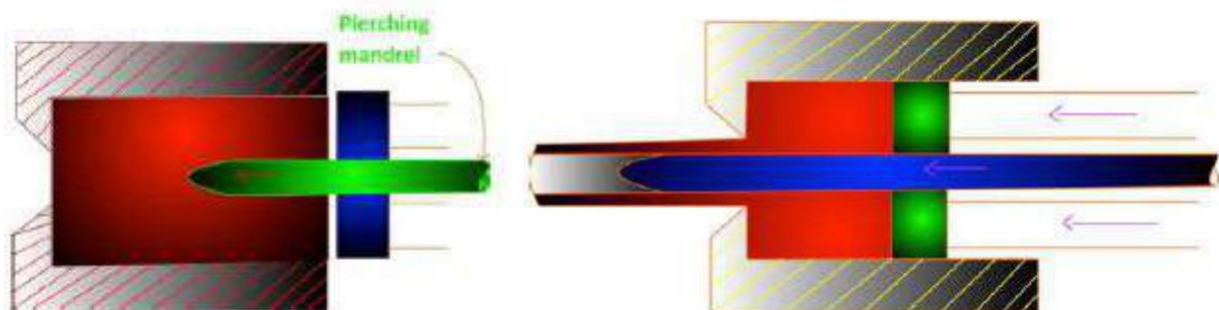

Tube extrusion

Tubes can also be made using solid billet and using a piercing mandrel to produce the hollow. The piercing mandrel is made to move independently with the help of hydraulic press. It moves along with the ram coaxially. First the ram upsets the billet, keeping the mandrel withdrawn. Next the mandrel pierces the billet and ejects a plug of material from central. Then the ram and mandrel together are moved in and extrude the billet.

### Wire Drawing

In drawing, the cross section of a long rod or wire is reduced or changed by pulling (hence the term drawing) it through a die called a draw die (Fig. 7.1). Thus, the difference between drawing and extrusion is that in extrusion the material is pushed through a die, whereas in drawing it is pulled through it. Although the presence of tensile stresses is obvious in drawing, compression also plays a significant role because the metal is squeezed down as it passes through the die opening. For this reason, the deformation that occurs in drawing is sometimes referred to as indirect compression. Drawing is a term also used in sheet metalworking. The term wire and bar drawing is used to distinguish the drawing process discussed here from the sheet metal process of the same name. Rod and wire products cover a very wide range of applications, including shafts for power transmission, machine and structural components, blanks for bolts and rivets, electrical wiring, cables,..Etc.

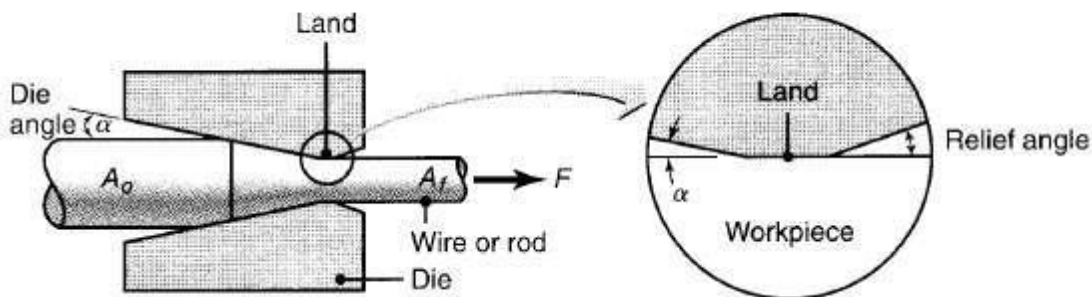

Process variables in wire drawing. The die angle, the reduction in cross sectional area per pass, the speed of drawing, the temperature and the lubrication all affect the drawing force,  $F$ .

The major processing variables in drawing are similar to those in extrusion that is, reduction in cross-sectional area, die angle, friction along the die-workpiece interface, and drawing speed.

The die angle influences the drawing force and the quality of the drawn product. The basic difference between bar drawing and wire drawing is the

stock size that is processed. Bar drawing is the term used for large diameter bar and rod stock, while wire drawing applies to small diameter stock. Wire sizes down to 0.03 mm (0.001 in) are possible in wire drawing. Bar drawing is generally accomplished as a single-draft operation—the stock is pulled through one die opening. Because the beginning stock has a large diameter, it is in the form of a straight cylindrical piece rather than coiled.

This limits the length of the work that can be drawn. By contrast, wire is drawn from coils consisting of several hundred (or even several thousand) feet of wire and is passed through a series of draw dies. The number of dies varies typically between 4 and 12. In a drawing operation, the change in size of the work is usually given by the area reduction, defined as follows:

$$r = \frac{A_o - A_f}{A_o}$$

Where  $r$ =area reduction in drawing;  $A_o$ =original area of work, mm<sup>2</sup> (in<sup>2</sup> ); and  $A_f$ =final area, mm<sup>2</sup> (in<sup>2</sup> ). Area reduction is often expressed as a percentage.

In bar drawing, rod drawing, and in drawing of large diameter wire for upsetting and heading operations, the term draft is used to denote the before and after difference in size of the processed work. The draft is simply the difference between original and final stock diameters:

Where  $d$  = draft, mm (in);  $D_o$  = original diameter of work, mm (in); and  $D_f$  = final work diameter, mm (in).

### **Tube Drawing:**

Drawing can be used to reduce the diameter or wall thickness of seamless tubes and pipes, after the initial tubing has been produced by some other process such as extrusion. Tube drawing can be carried out either with or without a mandrel. The simplest method uses no mandrel and is used for diameter reduction, as in Figure given below. The term tube sinking is sometimes applied to this operation.

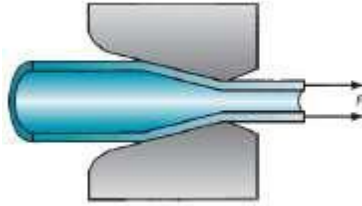

Tube drawing with no mandrel

The problem with tube drawing in which no mandrel is used, as in Figure above, is that it lacks control over the inside diameter and wall thickness of the tube. This is why mandrels of various types are used, two of which are illustrated in Figure below. The first, Figure (a) uses a fixed mandrel attached to a long support bar to establish inside diameter and wall thickness during the operation. Practical limitations on the length of the support bar in this method restrict the length of the tube that can be drawn. The second type, shown in (b), uses a floating plug whose shape is designed so that it finds a “natural” position in the reduction zone of the die. This method removes the limitations on work length present with the fixed mandrel.

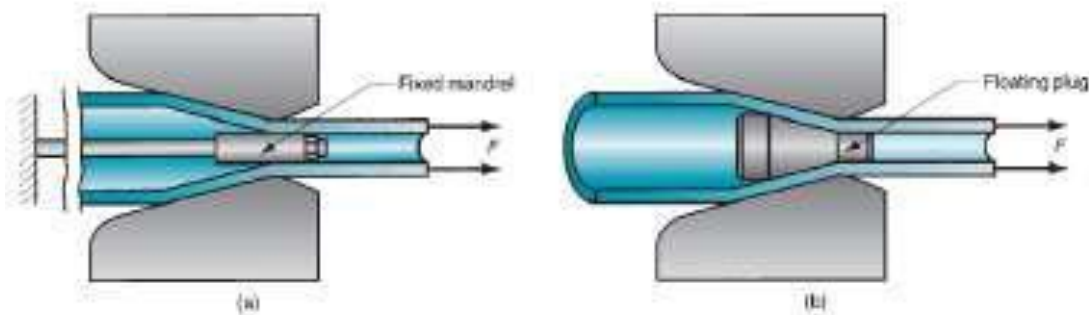

Fixed mandrel

Floating plug

### Drawing Equipment:

Bar drawing is accomplished on a machine called a draw bench, consisting of an entry table, die stand (which contains the draw die), carriage, and exit rack.

The arrangement is shown in Figure below. The carriage is used to pull the stock through the draw die. It is powered by hydraulic cylinders or motor-driven chains. The die stand is often designed to hold more than one die, so that several bars can be pulled simultaneously through their respective dies.

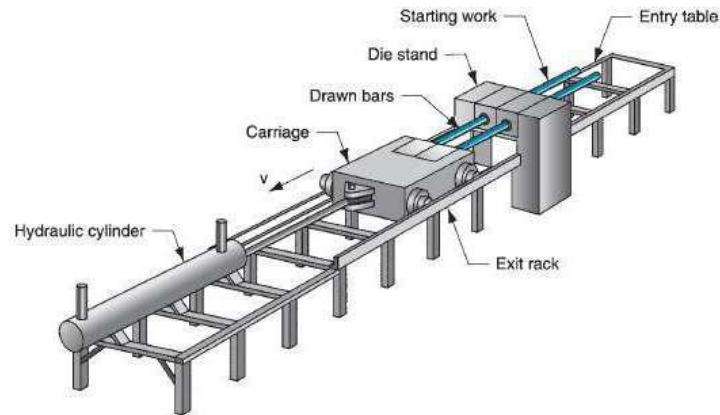

Hydraulically operated draw bench for drawing metal bars

Wire drawing is done on continuous drawing machines that consist of multiple draw dies, separated by accumulating drums between the dies, as in Figure 7.5. Each drum, called a capstan, is motor driven to provide the proper pull force to draw the wire stock through the upstream die. It also maintains a modest tension on the wire as it proceeds to the next draw die in the series. Each die provides a certain amount of reduction in the wire, so that the desired total reduction is achieved by the series. Depending on the metal to be processed and the total reduction, annealing of the wire is sometimes required between groups of dies in the series.

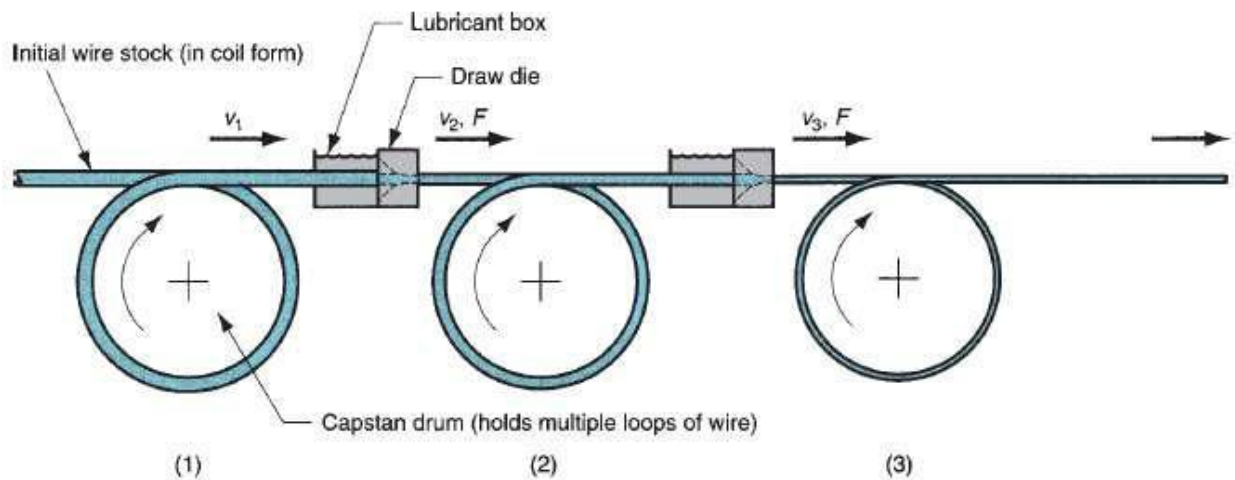

#### Draw Dies:

Figure given below identifies the features of a typical draw die. Four regions of the die can be distinguished: (1) entry, (2) approach angle, (3) bearing surface (land), and (4) back relief. The entry region is usually a

bell-shaped mouth that does not contact the work. Its purpose is to funnel the lubricant into the die and prevent scoring of work and die surfaces.

The approach is where the drawing process occurs. It is cone-shaped with an angle (half angle) normally ranging from about  $6^\circ$  to  $20^\circ$ . The proper angle varies according to work material. The bearing surface, or land, determines the size of the final drawn stock. Finally, the back relief is the exit zone. It is provided with a back relief angle (half-angle) of about  $30^\circ$ . Draw dies are made of tool steels or cemented carbides. Dies for high-speed wire drawing operations frequently use inserts made of diamond (both synthetic and natural) for the wear surfaces.

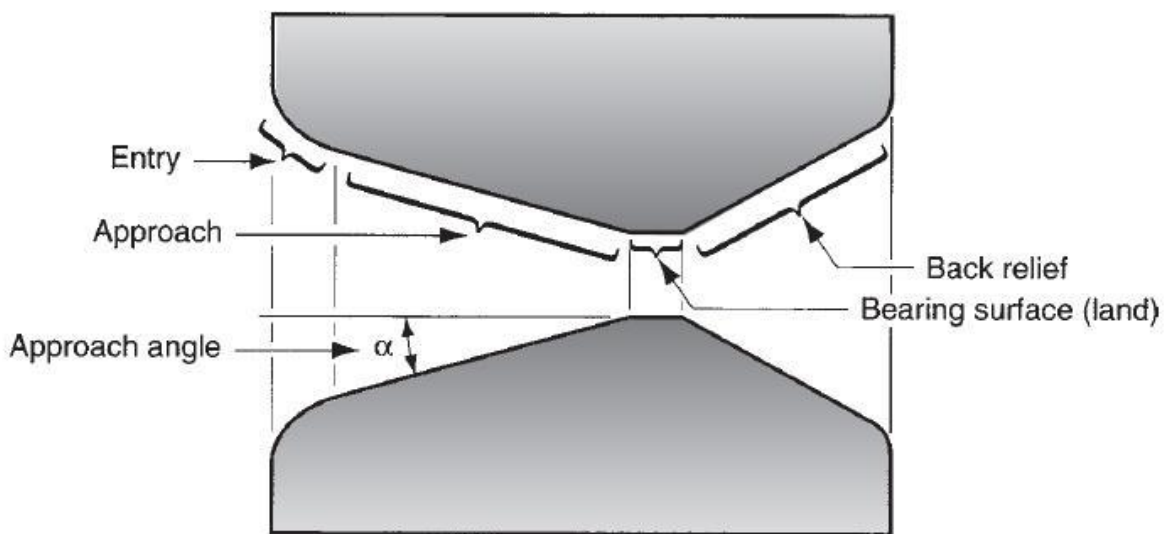

Draw die for drawing of round rod or wire.

### Die Material:

Die materials for drawing typically are tool Steels and carbides. For hot drawing, cast-steel dies are used because of their high resistance to wear at elevated temperatures. Diamond dies are used for drawing fine wire with diameters ranging from  $2\ \mu\text{m}$  to  $1.5\ \text{mm}$ . They may be made from a single-crystal diamond or in polycrystalline form with diamond particles in a metal matrix (compacts). Because of their very low tensile strength and toughness, carbide and diamond dies typically are used as inserts or nibs, which are supported in a steel casing.



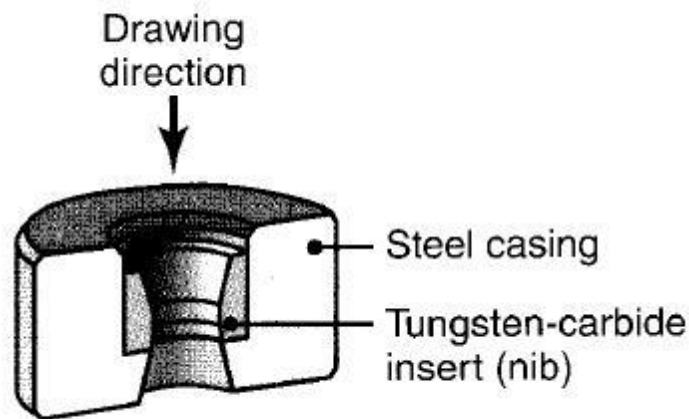

### Drawing Defects and Residual Stresses

Typical defects in a drawn rod or wire are **similar to those observed in extrusion** especially center cracking another major type of defect in drawing is **seams**, which are longitudinal scratches or folds in the material. Seams may open up during subsequent forming operations (such as upsetting, heading, thread rolling, or bending of the rod or wire), and they can cause serious quality-control problems. Various other surface defects (such as scratches and die marks) also can result from improper selection of the process parameters, poor lubrication, or poor die condition.

Because they undergo nonuniform deformation during drawing, cold-drawn products usually have residual stresses. For light reductions, such as only a few percent, the longitudinal-surface residual stresses are compressive (while the bulk is in tension) and fatigue life is thus improved. Conversely, heavier reductions induce tensile surface stresses (while the bulk is in compression). Residual stresses can be significant in causing stress-corrosion cracking of the part over time. Moreover, they cause the component to warp if a layer of material subsequently is removed such as by slitting, machining, or grinding.

Rods and tubes that are not sufficiently straight (or are supplied as coil) can be straightened by passing them through an arrangement of rolls placed at different axes.

### SHEET METAL WORKING

Sheet metal is simply metal formed into thin and flat pieces. It is one of the fundamental forms used in metalworking, and can be cut and bent

into a variety of different shapes. Countless everyday objects are constructed of the material. Thicknesses can vary significantly, although extremely thin thicknesses are considered foil or leaf, and pieces thicker than 6 mm (0.25 in) are considered plate.

### Sheet metal processing

The raw material for sheet metal manufacturing processes is the output of the rolling process. Typically, sheets of metal are sold as flat, rectangular sheets of standard size. If the sheets are thin and very long, they may be in the form of rolls. Therefore the first step in any sheet metal process is to cut the correct shape and sized 'blank' from larger sheet.

### Sheet metal forming processes

Sheet metal processes can be broken down into two major classifications and one minor classification

- **Shearing processes** -- processes which apply shearing forces to cut, fracture, or separate the material.
- **Forming processes** -- processes which cause the metal to undergo desired shape changes without failure, excessive thinning, or cracking. This includes bending and stretching.
- **Finishing processes** -- processes which are used to improve the final surface characteristics.

### Shearing Process

1. **Punching:** shearing process using a die and punch where the **interior** portion of the sheared sheet is to be **discarded**.
2. **Blanking:** shearing process using a die and punch where the **exterior** portion of the shearing operation is to be **discarded**.
3. **Perforating:** punching a number of holes in a sheet
4. **Parting:** shearing the sheet into two or more pieces
5. **Notching:** removing pieces from the edges
6. **Lancing:** leaving a tab without removing any material

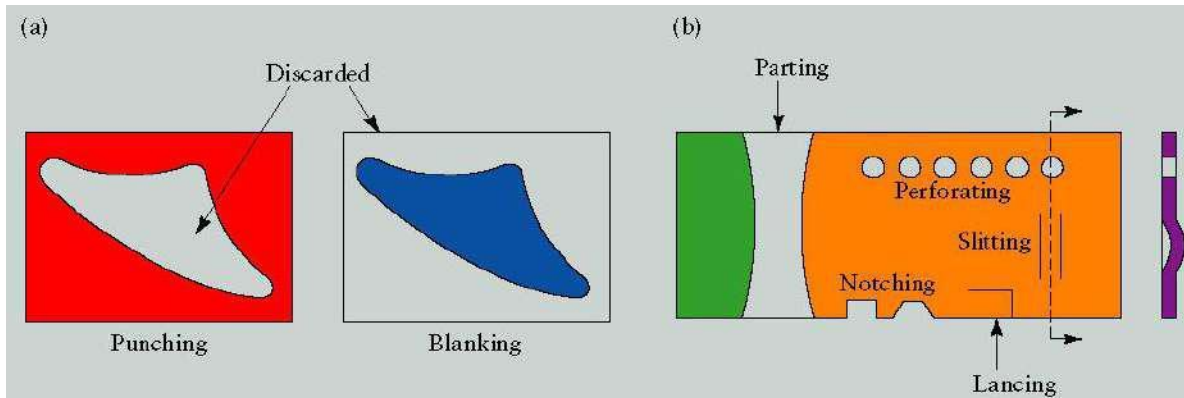

Shearing Operations: Punching, Blanking and Perforating

### Forming Processes

- **Bending:** forming process causes the sheet metal to undergo the desired shape change by bending without failure. Ref fig.2 & 2a
- **Stretching:** forming process causes the sheet metal to undergo the desired shape change by stretching without failure. Ref fig.3
- **Drawing:** forming process causes the sheet metal to undergo the desired shape change by drawing without failure.
- **Roll forming:** Roll forming is a process by which a metal strip is progressively bent as it passes through a series of forming rolls.
  - Common Die-Bending Operations

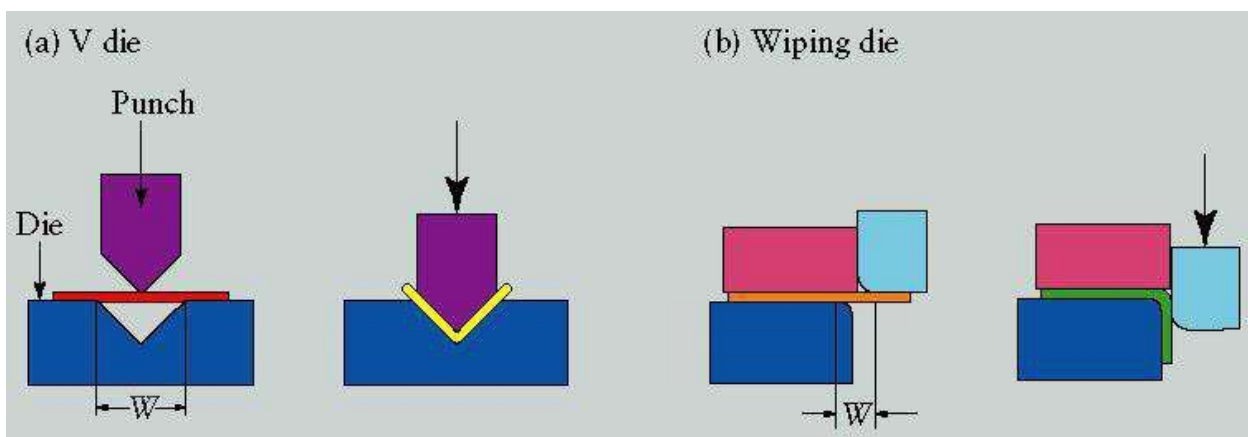

Common Die-Bending Operations

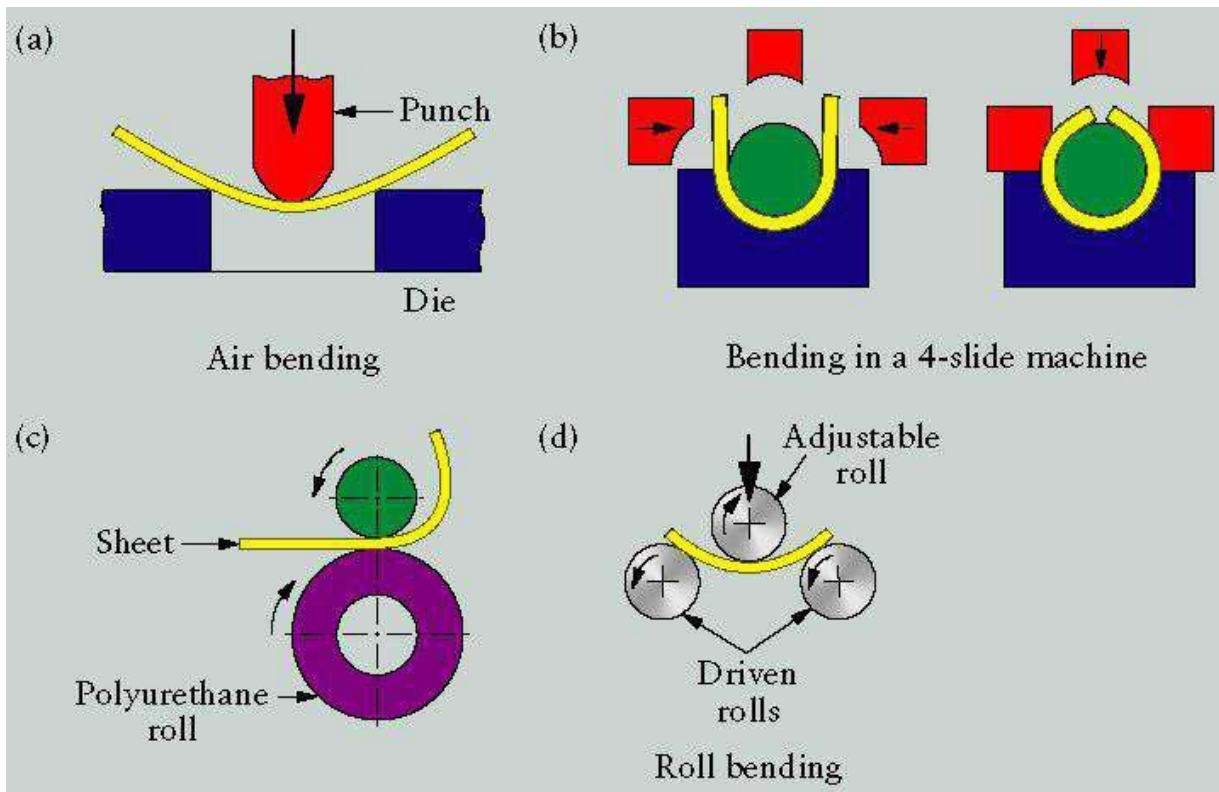

Various Bending Operations

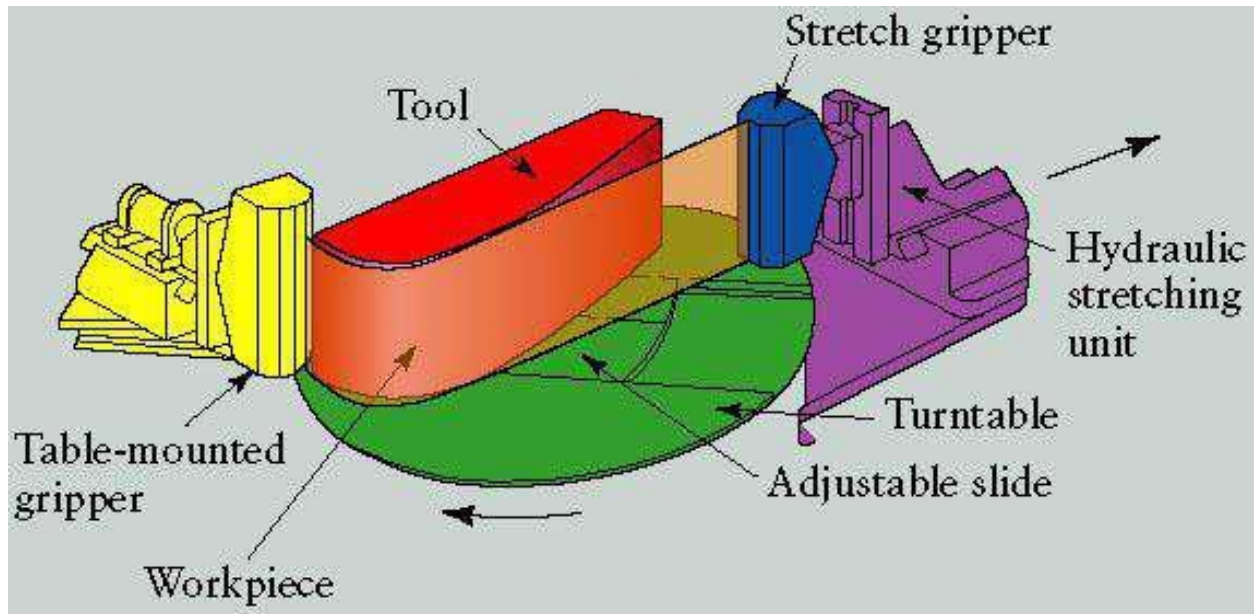

Schematic illustration of a stretch-forming process.

**Merits**

- High strength

- Good dimensional accuracy and surface finish
- Relatively low cost

### **Demerits**

- Wrinkling and tearing are typical limits to drawing operations
- Different techniques can be used to overcome these limitations
  - Draw beads
  - Vertical projections and matching grooves in the die and blank holder
- Trimming may be used to reach final dimensions

### **Applications**

- Roofings
- Ductings
- Vehicles body buildings like 3 wheelers, 4 wheelers, ships, aircrafts etc.
- Furnitures, House hold articles and Railway equipment

**Explosive forming** is a metalworking technique in which an explosive charge is used instead of a punch or press. It can be used on materials for which a press setup would be prohibitively large or require an unreasonably high pressure, and is generally much cheaper than building a large enough and sufficiently high-pressure press; on the other hand, it is unavoidably an individual job production process, producing one product at a time and with a long setup time. The schematic diagram of explosive forming is shown below:

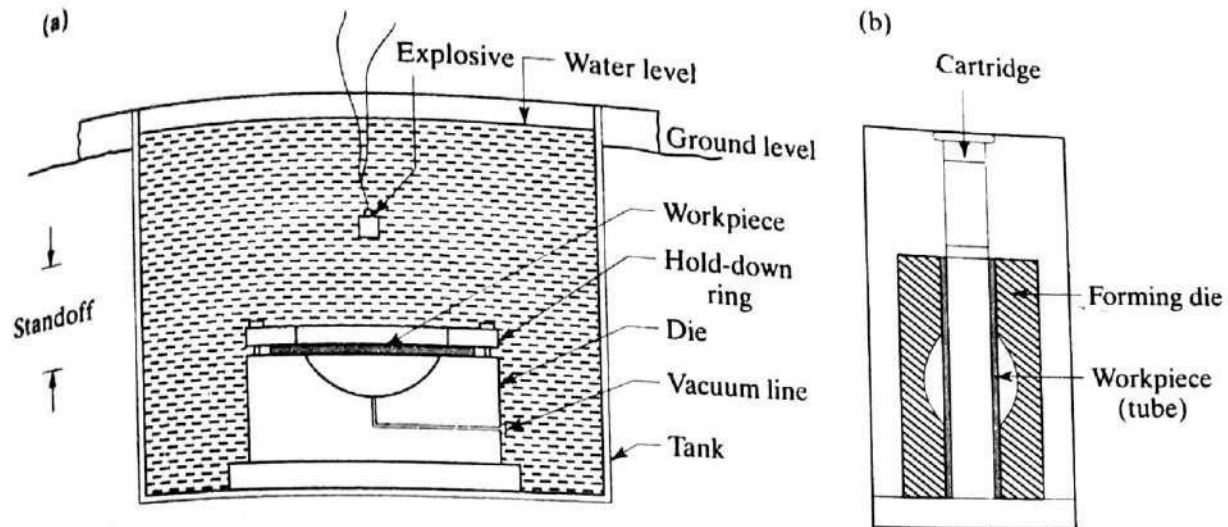

(a) Schematic illustration of the explosive forming process

(b) Illustration of the confined method of explosive bulging of tubes.

The energy was first utilized to form metals in early 1900s. Typically, in explosive forming the sheet metal blank is clamped over a die and the entire assembly is lowered into a tank filled with water. The air in the die cavity is evacuated, an explosive charge is placed at a certain height and the charge is detonated. The rapid conversion of the explosive charge into gas generates a shock wave. The pressure of this wave is sufficient to form sheet metals. The peak pressure  $P$  due to the explosion, generated in water is given by the expression

$$P = \frac{3}{7} \left( \frac{W}{R^2} \right)^{1/3}$$

Where,  $P$  is in psi,  $k$  is a constant which depends on the type of explosive,  $W$  is the weight of the explosive in pound,  $R$  is the distance of the explosive from the work piece surface( standoff) in feet and  $a$  is a constant, generally taken to be 1.15.

A variety of shapes can be formed by the use of this process, provided that the material is ductile at the high rates of deformation characteristics of the explosive nature of the process. Explosive forming is versatile – there is virtually no limit to the size of the work-piece and it is particularly suitable for low quantity production runs of large parts, such as occur in aerospace applications.

Steel plates 25mm thick and 3.6m in diameter have been formed by this method. Tubes having walls as thick as 25mm have been bulged by explosive forming techniques.

The mechanical properties of the parts made by this process are basically the same as those of parts made by conventional forming methods. Depending on the number of parts to be produced, dies may be made of aluminium alloy, reinforced concrete, wood, plastics or composite materials.

### Applications

Some of the applications of explosive forming include:

- Sheet metal panels
- Tubing
- Housings
- Jet engine parts
- Missile nose cones
- Ducts

### Materials for explosive forming

- Both ferrous and nonferrous metals including steel, aluminum, magnesium, and their alloys.
- Some metal matrix composites like aluminum matrix, copper matrix and lead matrix composites.

### Process Variations

- Explosives can be placed at a fixed distance from the workpiece. After detonation the explosive forces travel through the intervening medium to reach the work piece. This method is called the standoff method.
- Alternatively, the explosive can be placed directly on the work piece. Upon detonation, explosive forces hit the work piece directly. This is called the contact method.

### Design Considerations

- Section thickness at any point should be in the range of 1 mm to 10mm.
- Tolerance of 0.25mm to 1mm should be provided.
- Surface roughness of 1.575mm to 12.3mm can be achieved.

#### Economic Considerations

- Slow production rate of 0.5 to 6 pieces per hour.
- High labor skills required.
- Low equipment costs, moderate tooling costs.
- Economical for batch production.

#### Quality Considerations

- Explosives contaminate the transfer media, which need to be cleaned each time for better quality and process control.
- It is difficult to control the mechanical properties and dimensions of the part.

#### Advantages

- Complex shapes can be produced.
- Smoothness of the contour can be controlled.
- Cheap alternative to Superplastic Forming.

#### Disadvantages

- Only viable for low production volumes.
- Handling explosives requires great care and safety precautions.

-----END-----