

MODULE-1

1. UNDERSTAND THE CONSTRUCTION AND WORKING OF POWER ELECTRONIC DEVICES

1.1 CONSTRUCTION, OPERATION, V-I CHARACTERISTICS & APPLICATION OF POWER DIODE, SCR, DIAC, TRIAC, POWER MOSFET, GTO & IGBT

POWER DIODE

Basic structure:

Power diode consists of three layers. Top layer is a heavily doped P+ layer. Middle layer is lightly doped n- layer and the last layer is a heavily doped n+ layer. The heavily doped p+ layer act as an anode. The thickness of this layer is around 10 μm and doping level is 10^{19} cm^{-3} . Last layer of the heavily doped n+ act as a cathode. The thickness of this layer is around 250 to 300 μm and doping level is 10^{19} cm^{-3} . Middle layer of lightly doped n- is known as a drift layer. The thickness of the drift layer depends on the required breakdown voltage. The breakdown voltage increases with an increase in the width of the drift layer. Resistivity of this layer is high because of the low level of doping. If the width of the drift layer increased, then the on-state voltage drop increase therefore power loss is more. The doping level of the drift layer is 10^{14} cm^{-3} . The junction is form between the anode layer (p+) and drift layer (n-). The cross-section area of the diode depends on the magnitude of current to be handled. Higher the current to handle, more the area required.

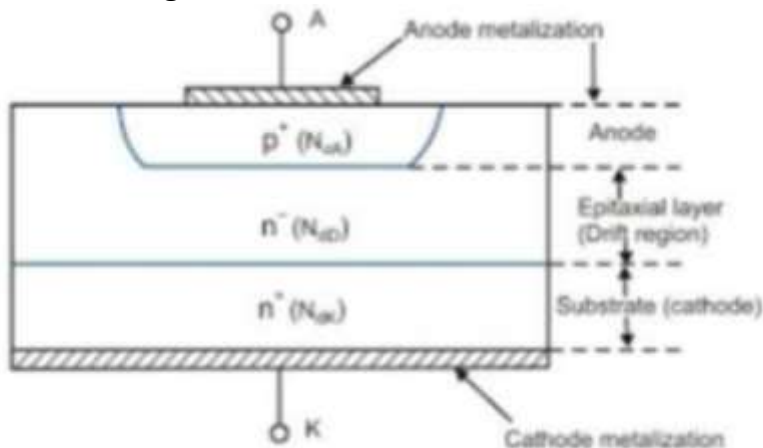

Operating Principle of Power diode:

The operating principle of power diode is same as the conventional PN junction diode. A diode conducts when the anode voltage is higher than the cathode voltage. The forward voltage drop across the diode is very low around 0.5V to 1.2V. In this region, the diode works as a forward characteristic.

If the cathode voltage is higher than the anode voltage, then the diode works as blocking mode. In this mode, diode works according to the reverse characteristic.

V-I characteristic of Power Diode:

Power semiconductor diodes are similar to low-power $p-n$ junction diodes, called signal diodes. Similarly, power transistors are identical with npn or pnp signal transistors. As a matter of fact, power semiconductor devices are more complex in structure and in operation than their low-power counterparts. This complexity arises because low-power devices must be modified in order to make them suitable for high-power applications, for example, power diodes are constructed with n^- layer, called drift region, between p^+ layer (anode) and n^+ layer or substrate (cathode). This is done to support large blocking voltages. This n^- type layer is, however, not present in signal diodes.

The voltage, current and power ratings of power diodes and transistors are much higher than the corresponding ratings for signal devices. In addition, power devices operate at lower switching speeds whereas signal diodes and transistors operate at higher switching speeds.

Power semiconductor devices are used extensively in power-electronic circuits. Some applications of power diodes include their use as freewheeling diodes, for ac to dc conversion, for recovery of trapped energy etc. Power transistors, used as a switching device in power-electronic circuits, must operate in the saturation region in order that their on-state voltage drop is low. Their applications as switching elements include dc choppers and inverters.

The object of this chapter is to describe power diodes, power transistors and MOS-controlled thyristor (MCT). A thyristor is more important component of power semiconductor devices, it is, therefore, discussed in detail in Chapter 4.

2.1. CHARACTERISTICS OF POWER DIODES

Power diode is a two-layer, two-terminal, $p-n$ semiconductor device. It has one pn -junction formed by alloying, diffusing or epitaxial growth. The two terminals of diode are called anode and cathode, Fig. 2.1 (a). Two important characteristics of power diodes are now described.

2.1.1. Diode V-I Characteristics

When anode is positive with respect to cathode, diode is said to be *forward biased*. With increase of the source voltage V_s from zero value, initially diode current is zero. From $V_s = 0$ to cut-in voltage, the forward-diode current is very small. *Cut-in voltage* is also known as *threshold voltage* or *turn-on voltage*. Beyond cut-in voltage, the diode current rises rapidly and the diode is said to conduct. For silicon diode, the cut-in voltage is around 0.7 V. When diode conducts, there is a forward voltage drop of the order of 0.8 to 1 V.

When cathode is positive with respect to anode, the diode is said to be *reverse biased*. In the *reverse biased* condition of the diode, a small reverse current, called leakage current, of the order of microamperes or milliamperes (for large diodes) flows. The leakage current increases slowly with the reverse voltage until breakdown or avalanche voltage is reached. At this breakdown voltage, diode is turned on in the reversed direction. If current in the reversed direction is not limited by a series resistance, the current will become quite high to destroy the diode. The reverse avalanche breakdown of a diode is avoided by operating the diode below specified peak repetitive reverse voltage V_{RRM} . Fig. 2.1 (c) illustrates diode characteristics where V_{RRM} and cut-in voltage are shown.

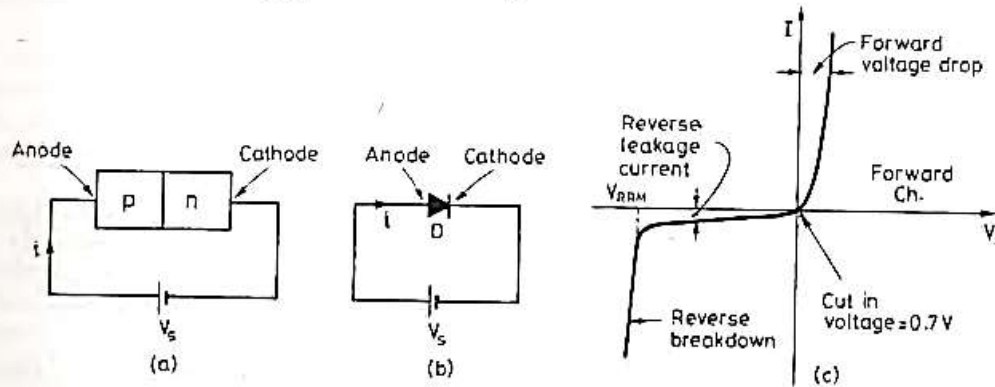
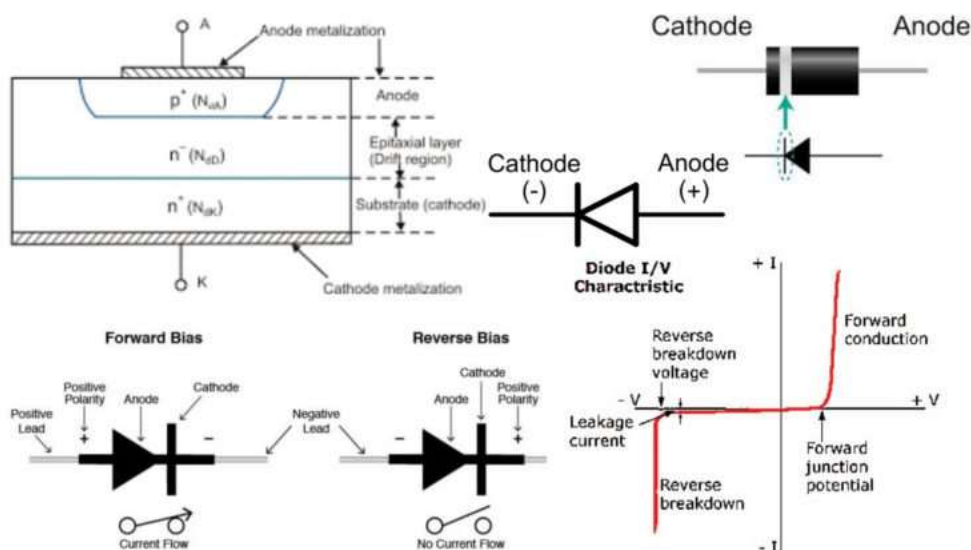

Fig. 2.1. (a) p-n junction (b) diode symbol (c) V-I characteristics of diode.

Diode manufacturers also indicate the value of peak inverse voltage (PIV) of a diode. This is the largest reverse voltage to which a diode may be subjected during its working. PIV is the same as V_{RRM} .

The power diodes are now available with forward current ratings of 1 A to several thousand amperes and with reverse voltage ratings of 50 V to 3000 V or more.



Application of Power Diode in Power Electronics:

1. High voltage rectifier
2. As freewheeling diode
3. As feedback diode

POWER BJT

Construction of Power BJT:

The power BJT has three terminals **Collector (C)**, **Emitter (E)** and **Base (B)**. It has a vertically oriented four-layers structure. The vertical structure uses to increase the cross-sectional area. There are two types of BJT; **n-p-n transistor** and **p-n-p transistor**. Out of these two types, the n-p-n transistors widely use compare to the p-n-p transistor. It has four layers. The first layer is a heavily doped **emitter layer (n+)**. The second layer is moderately doped the **base layer (p)**. The third region is lightly doped **collector drift region (n-)**. The last layer is a highly doped **collector region (n+)**. The drift layer (n-) increase the voltage blocking capacity of the transistor due to the low doping level. The width of this layer decides the breakdown voltage. The disadvantage of this layer is that the increase on state voltage drops and increase on state device resistance, which increases power loss. The power handling capacity of the power transistor is very large. So, they have to dissipate power in the form of heat. Sometimes, heatsink uses to increase effective area and therefore increase power dissipation capacity. the heatsink made from metal.

2.3.1. Bipolar Junction Transistors

A bipolar transistor is a three-layer, two junction *npn* or *pnp* semiconductor device. With one *p*-region sandwiched by two *n*-regions, Fig. 2.3 (a), *npn* transistor is obtained. With two *p*-regions sandwiching one *n*-region, Fig. 2.3 (b), *pnp* transistor is obtained. The term 'bipolar' denotes that the current flow in the device is due to the movement of both holes and electrons. A BJT has three terminals named collector, emitter and base. An emitter is indicated by an arrowhead indicating the direction of emitter current. No arrow is associated with base or collector.

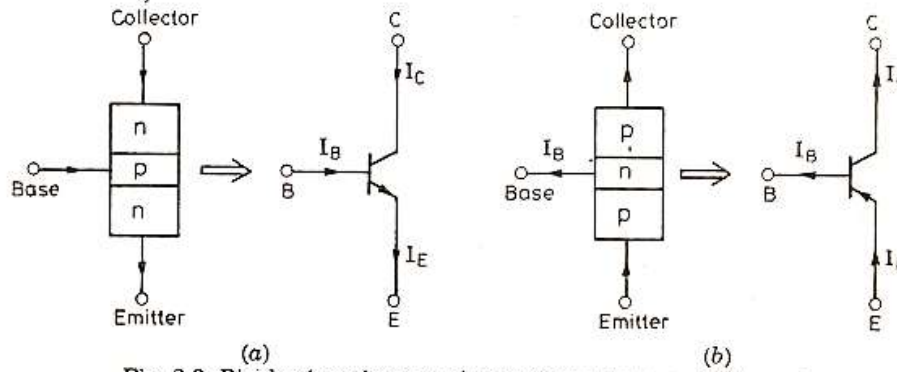

Fig. 2.3. Bipolar junction transistors (a) *npn* type and (b) *pnp* type.

2.3.1.1. Steady-state Characteristics. Out of the three possible circuit configurations for a transistor, common-emitter arrangement is more common in switching applications. So, henceforth, *npn* transistors will only be considered.

Input characteristics. A graph between base current I_B and base-emitter voltage V_{BE} gives input characteristics. As the base-emitter junction of a transistor is like a diode, I_B versus V_{BE} graph resembles a diode curve. When collector-emitter voltage V_{CE2} is more than V_{CE1} , base current decreases as shown in Fig. 2.4 (b).

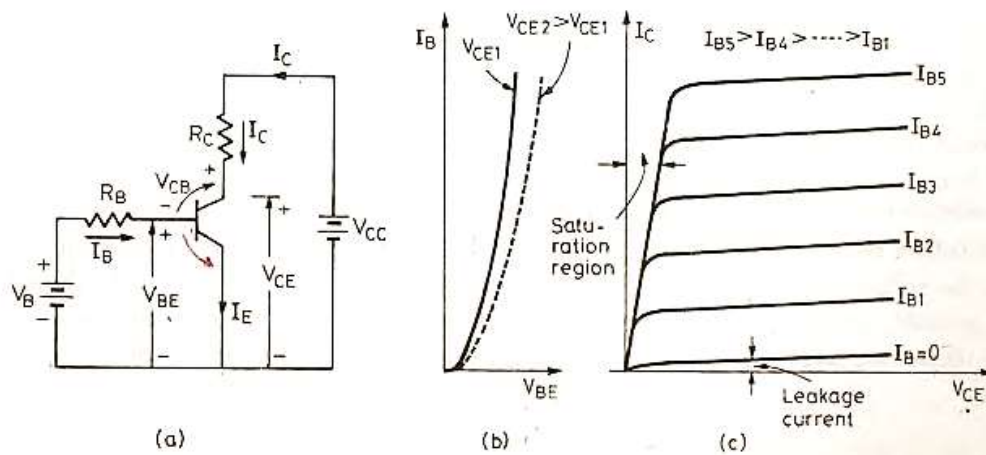

Fig. 2.4. (a) *npn* transistor circuit characteristics, (b) input characteristics and (c) output characteristics.

Output characteristics. A graph between collector current I_C and collector-emitter voltage V_{CE} gives output characteristics of a transistor. For zero base current, i.e. for $I_B = 0$, as V_{CE} is increased, a small leakage (collector) current exists as shown in Fig. 2.4 (c). As the base current is increased from $I_B = 0$ to I_{B1}, I_{B2} etc, collector current also rises as shown in Fig. 2.4 (c).

Fig. 2.5 (a) shows two of the output characteristic curves, 1 for $I_B = 0$ and 2 for $I_B \neq 0$. The initial part of curve 2, characterised by low V_{CE} , is called the saturation region. In this region, the transistor acts like a switch. The flat part of curve 2, indicated by increasing V_{CE} and almost constant I_C , is the active region. In this region, transistor acts like an amplifier. Almost vertically rising curve is the breakdown region which must be avoided at all costs.

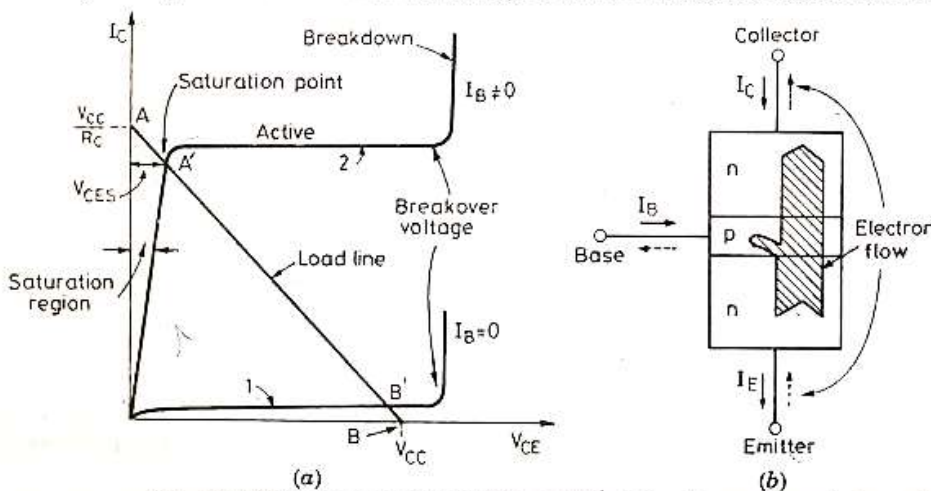

Fig. 2.5. (a) Output characteristics and load line for $n-p-n$ transistor and (b) electron flow in an $n-p-n$ transistor.

For load resistor R_C , Fig. 2.4 (a), the collector current I_C is given by

$$I_C = \frac{V_{CC} - V_{CE}}{R_C} \quad \dots(2.6)$$

This is the equation of load line. It is shown as line AB in Fig. 2.5 (a). A load line is the locus of all possible operating points. Ideally, when transistor is on, V_{CE} is zero and $I_C = V_{CC}/R_C$. This collector current is shown by point A on the vertical axis. When the transistor is off, or in the cut-off region, V_{CC} appears across collector-emitter terminals and there is no collector current. This value is indicated by point B on the horizontal axis. For the resistive load, the line joining points A and B is the load line.

Relation between α and β . Most of the electrons, proportional to I_E , given out by emitter, reach the collector as shown in Fig. 2.5 (b). In other words, collector current I_C , though less than emitter current I_E , is almost equal to I_E . A symbol α is used to indicate how close in value these two currents are. Here α , called *forward current gain*, is defined as

$$\alpha = \frac{I_C}{I_E}$$

As $I_C < I_E$, value of α varies from 0.95 to 0.99.

In a transistor, base current is effectively the input current and collector current is the output current. The ratio of collector (output) current I_C to base (input) current I_B is known as the *current gain* β .

$$\therefore \beta = \frac{I_C}{I_B} \quad \dots(2.7)$$

As I_B is much smaller, β is much more than unity ; its value varies from 50 to 300. In another system of analysis, called h parameters, h_{FE} is used in place of β .

$$\therefore \beta = h_{FE} = \frac{I_C}{I_B}$$

Use of KCL in Fig. 2.4 (a) gives

$$I_E = I_C + I_B \quad \dots(2.8)$$

Remember that emitter current is the largest of the three currents, collector current is almost equal to, but less than, emitter current. Base current has the least value. Dividing both sides of Eq. (2.8) by I_C , we get

$$\frac{I_E}{I_C} = 1 + \frac{I_B}{I_C}$$

$$\frac{1}{\alpha} = 1 + \frac{1}{\beta}$$

or

$$\beta = \frac{\alpha}{1 - \alpha} \quad \dots(2.9)$$

and

$$\alpha = \frac{\beta}{\beta + 1} \quad \dots(2.10)$$

POWER MOSFET

A power MOSFET has three terminal devices. Arrow indicates the direction of current flow. MOSFET is a voltage controlled device. The operation of MOSFET depends on flow of majority carriers only.

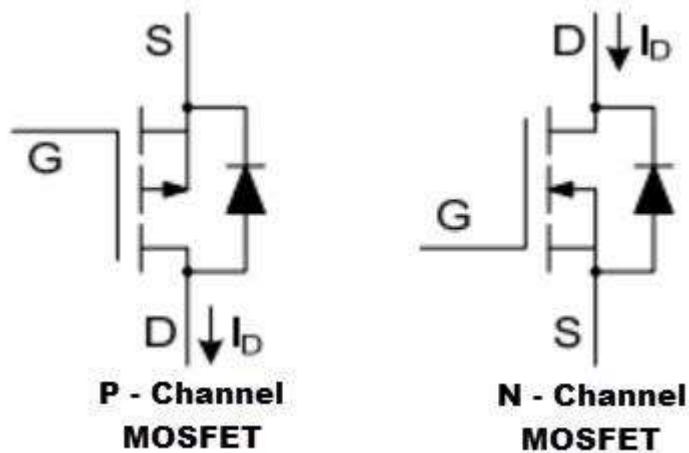

The Power MOSFET is a type of MOSFET. The operating principle of power MOSFET is similar to the general MOSFET. The power MOSFETS are very special to handle the high level of powers. It shows the high switching speed and by comparing with the normal MOSFET, the power MOSFET will work better. The power MOSFETs is widely used in the n-channel enhancement mode, p-channel enhancement mode, and in the nature of n-channel depletion mode. Here we have explained about the N-channel power MOSFET. The design of power MOSFET was made by using the CMOS technology and also used for development of manufacturing the integrated circuits in the 1970s. A power MOSFET is a special type of metal oxide semiconductor field effect transistor. It is specially designed to handle high-level powers.

Working of Power MOSFET and Characteristics:
The construction of the power MOSFET is in V-configurations, as we can see in the following figure. Thus, the device is also called as the V-MOSFET or V-FET. The V-shape of power MOSFET is cut to penetrate from the device surface is almost to the N+ substrate to the N+, P, and N – layers. The N+ layer is the heavily doped layer with a low resistive material and the N- layer is a lightly doped layer with the high resistance region.

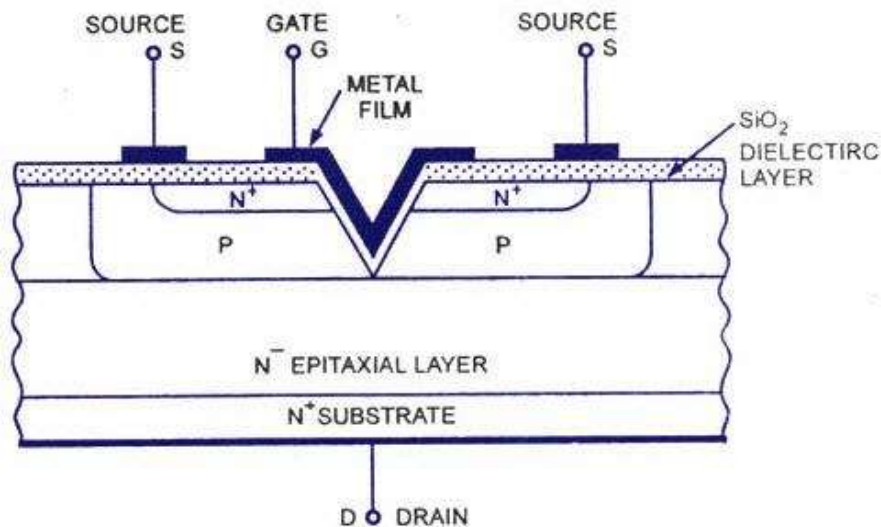

(N – Channel Power MOSFET)

Both the horizontal and the V cut surface are covered by the silicon dioxide dielectric layer and the insulated gate metal film is deposited on the SiO₂ in the V-shape. The source terminal contacts with the both N⁺ and P- layers through the SiO₂ layer. The drain terminal of this device is N⁺. The V-MOSFET is an E-mode FET and there is no exists of the channel in between the drain & source till the gate is positive with respect to the source. If we consider the gate is positive with respect to the source, then there is a formation of the N-type channel which is close to the gate and it is in the case of the E-MOSFET. In the case of E-MOSFET, the N-type channel provides the vertical path for the charge carriers. To flow between the drain and source terminals. If the V_{GS} is zero or negative, then there is no channel of presence and the drain current is zero. The following figures show the drain & transfer characteristics for the enhancement mode of N-channel power MOSFET is similar to the E-MOSFET. If there is an increase in the gate voltage then the channel resistance is reduced, therefore the drain current I_D is increased. Hence the drain current I_D is controlled by the gate voltage control. So that for a given level of V_{GS}, I_D is remaining constant through a wide range of V_{DS} levels.

A metal-oxide-semiconductor field-effect transistor (MOSFET) is a recent device developed by combining the areas of field-effect concept and MOS technology.

A power MOSFET has three terminals called drain, source and gate in place of the corresponding three terminals collector, emitter and base for BJT. The circuit symbol of power MOSFET is as shown in Fig. 2.11 (a). Here arrow indicates the direction of electron flow. A BJT is a current controlled device whereas a power MOSFET is a voltage-controlled device. As its operation depends upon the flow of majority carriers only, MOSFET is a unipolar device. The control signal, or base current in BJT is much larger than the control signal (or gate current) required in a MOSFET. This is because of the fact that gate circuit impedance in MOSFET is extremely high, of the order of 10^9 ohm. This large impedance permits the MOSFET gate to be driven directly from microelectronic circuits. BJT suffers from second breakdown voltage whereas MOSFET is free from this problem. Power MOSFETs are now finding increasing applications in low-power high frequency converters.

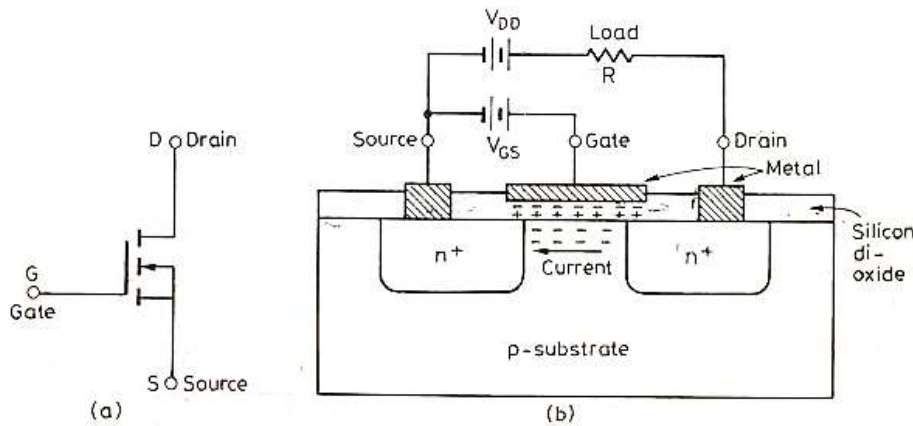

Fig. 2.11. *N*-channel enhancement power MOSFET
(a) circuit symbol and (b) its basic structure.

Power MOSFETs are of two types ; *n*-channel enhancement MOSFET and *p*-channel enhancement MOSFET. Out of these two types, *n*-channel enhancement MOSFET is more common because of higher mobility of electrons. As such, only this type of MOSFET is studied in what follows.

A simplified structure of n -channel planar MOSFET of low power rating is shown in Fig. 2.11 (b). On p -substrate (or body), two heavily doped n^+ regions are diffused as shown. An insulating layer of silicon dioxide (SiO_2) is grown on the surface. Now this insulating layer is etched in order to embed metallic source and drain terminals. Note that n^+ regions make contact with source and drain terminals as shown. A layer of metal is also deposited on SiO_2 layer so as to form the gate of MOSFET.

When gate circuit is open, no current flows from drain to source and load because of one reverse-biased $n^+ - p$ junction. When gate is made positive with respect to source, an electric field is established as shown in Fig. 2.11 (b). Eventually, induced negative charges in the p -substrate below SiO_2 layer are formed. These negative charges, called electrons, form n -channel and current can flow from drain to source as shown by the arrow. If V_{GS} is made more positive, n -channel becomes more deep and therefore more current flows from D to S . This shows that drain current I_D is enhanced by the gradual increase of gate voltage, hence the name enhancement MOSFET.

The main disadvantage of n -channel planar MOSFET of Fig. 2.11 (b) is that conducting n -channel in between drain and source gives large on-state resistance. This leads to high power dissipation in n -channel. This shows that planar MOSFET construction of Fig. 2.11 (b) is feasible only for low-power MOSFETs.

The constructional details of high power MOSFET are illustrated in Fig. 2.12. In this figure is shown a planar diffused metal-oxide-semiconductor (DMOS) structure for n -channel

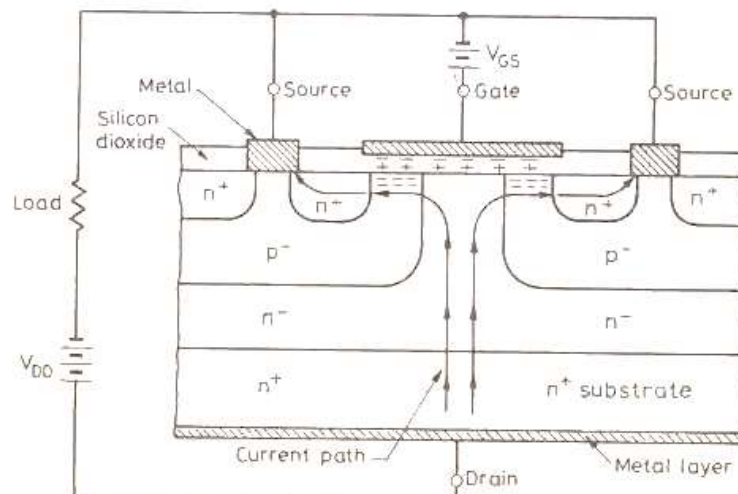

Fig. 2.12. Basic structure of a n -channel DMOS power MOSFET.

which is quite common for power MOSFETs. On n^+ substrate, high resistivity n^- layer is epitaxially grown. The thickness of n^- layer determines the voltage blocking capability of the device. On the other side of n^+ substrate, a metal layer is deposited to form the drain terminal. Now p^- regions are diffused in the epitaxially grown n^- layer. Further, n^+ regions are diffused in p^- regions as shown. As before, SiO_2 layer is added, which is then etched so as

to fit metallic source and gate terminals. A power MOSFET actually consists of a parallel connection of thousands of basic MOSFET cells on the same single chip of silicon.

When gate circuit voltage is zero, and V_{DD} is present, $n^- - p^-$ junctions are reverse biased and no current flows from drain to source. When gate terminal is made positive with respect to source, an electric field is established and electrons form n -channel in the p^- regions as shown. So a current from drain to source is established as indicated by arrows. With gate voltage increased current I_D also increases as expected. Length of n -channel can be controlled and therefore on-resistance can be made low if short length is used for the channel.

Power MOSFET conduction is due to majority carriers, therefore, time delays caused by removal or recombination of minority carriers are eliminated. Thus, power MOSFET can work at switching frequencies in the megahertz range.

2.4.1. MOSFET Characteristics

The static characteristics of power MOSFET are now described briefly. The basic circuit diagram for n -channel power MOSFET is shown in Fig. 2.13 (a) where voltages and currents are as indicated.

(a) **Transfer characteristics.** This characteristic shows the variation of drain current I_D as a function of gate-source voltage V_{GS} . Fig. 2.13 (b) shows typical transfer characteristic for n -channel power MOSFET. It is seen that there is threshold voltage V_{GST} below which the device is off. The magnitude of V_{GST} is of the order of 2 to 3 V.

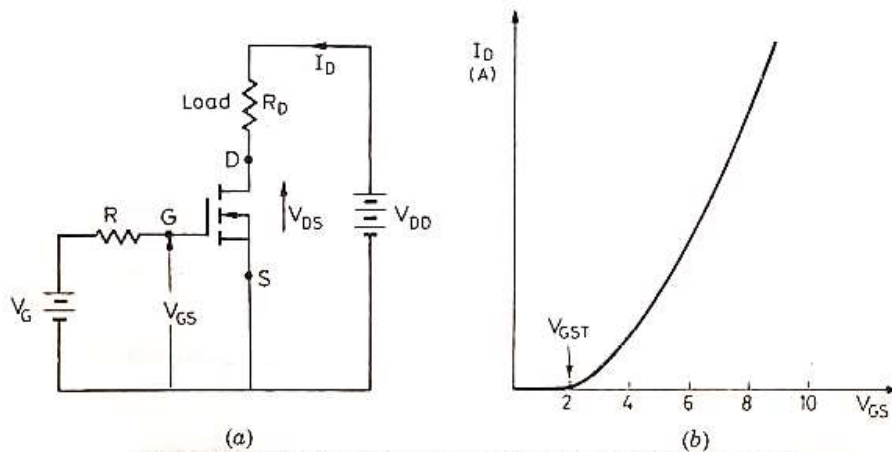

Fig. 2.13. (a) N -channel power MOSFET circuit diagram and (b) its typical transfer characteristic.

(b) **Output characteristics.** Power MOSFET output characteristics shown in Fig. 2.14 indicate the variation of drain current I_D as a function of drain-source voltage V_{DS} as a parameter. For low values of V_{DS} , the graph between $I_D - V_{DS}$ is almost linear; this indicates a constant value of on-resistance $R_{DS} = V_{DS}/I_D$. For given V_{GS} , if V_{DS} is increased, output characteristic is relatively flat indicating that drain current is nearly constant. A load line intersects the output characteristics at A and B. Here A indicates fully-on condition and B fully-off state. Power MOSFET operates as a switch either at A or at B just like a BJT.

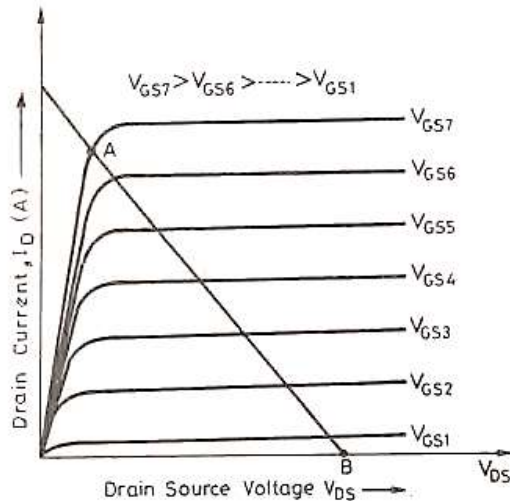

Fig. 2.14. Output characteristics of a power MOSFET.

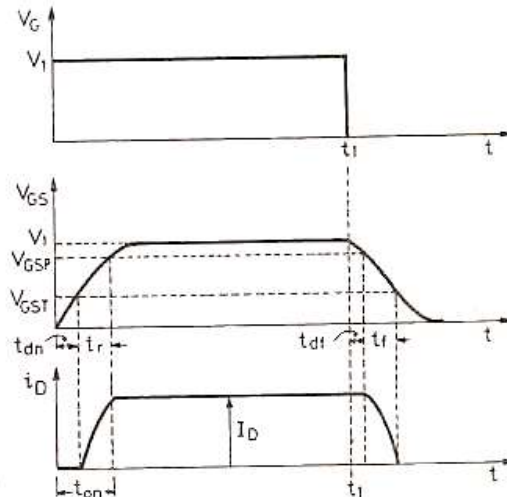

Fig. 2.15. Switching waveforms for power MOSFET.

(c) **Switching characteristics.** The switching characteristics of a power MOSFET are influenced to a large extent by the internal capacitance of the device and the internal impedance of the gate drive circuit. At turn-on, there is an initial delay t_{dn} during which input capacitance charges to gate threshold voltage V_{GST} . Here t_{dn} is called *turn-on delay time*.

There is further delay t_r , called *rise time*, during which gate voltage rises to V_{GSP} , a voltage sufficient to drive the MOSFET into on state. During t_r , drain current rises from zero to full on current I_D . Thus, the total turn-on time is $t_{on} = t_{dn} + t_r$. The turn-on time can be reduced by using low-impedance gate drive source.

As MOSFET is a majority carrier device, turn-off process is initiated soon after removal of gate voltage at time t_1 . The turn-off delay time, t_{df} is the time during which input capacitance discharges from overdrive gate voltage V_1 to V_{GSP} . The *fall time*, t_f is the time during which input capacitance discharges from V_{GSP} to threshold voltage. During t_f , drain current falls from I_D to zero. So when $V_{GS} \leq V_{GST}$, MOSFET turn-off is complete. Switching waveforms for a power MOSFET are shown in Fig. 2.15.

Power MOSFETs are very popular in switched mode power supplies. They are, at present, available with 500 V, 140 A ratings.

2.4.2. Comparison of MOSFET with BJT

Power MOSFET has several features different from those of BJT. These are outlined as under :

(i) Power MOSFET has lower switching losses but its on-resistance and conduction losses are more. A BJT has higher switching losses but lower conduction loss. So at high frequency applications, power MOSFET is the obvious choice. But at lower operating frequencies (less than about 10 to 30 kHz), BJT is superior.

(ii) MOSFET is voltage controlled device whereas BJT is current controlled device.

(iii) MOSFET has positive temperature coefficient for resistance. This makes parallel operation of MOSFETs easy. If a MOSFET shares increased current initially, it heats up

faster, its resistance rises and this increased resistance causes this current to shift to other devices in parallel. A BJT has negative temperature coefficient, so current-sharing resistors are necessary during parallel operation of BJTs.

(iv) In MOSFET, secondary breakdown does not occur, because it has positive temperature coefficient. As BJT has negative temperature coefficient, secondary breakdown occurs. In BJT, with decrease in resistance, the current increases. This increased current over the same area results in hot spots and breakdown of the BJT.

(v) Power MOSFETs in higher voltage ratings have more conduction loss.

(vi) The state of the art MOSFETs are available with ratings upto 500 V, 140 A whereas BJTs are available with ratings up to 1200 V, 800 A.

Applications of Power MOSFET

The power MOSFET's are used in the power supplies

- DC to DC converters
- Low voltage motor controllers
- These are widely used in the low voltage switches which are less than the 200V

INSULATED GATE BIPOLAR TRANSISTOR(IGBT)

BASIC CONSTRUCTION

The n+ layer substrate at the drain in the power MOSFET is substituted by p+ layer substrate and called as collector. When gate to emitter voltage is positive, n- channel is formed in the p region. This n- channel short circuit the n- and n+ layer and an electron movement in n channel cause hole injection from p+ substrate layer to n- layer.

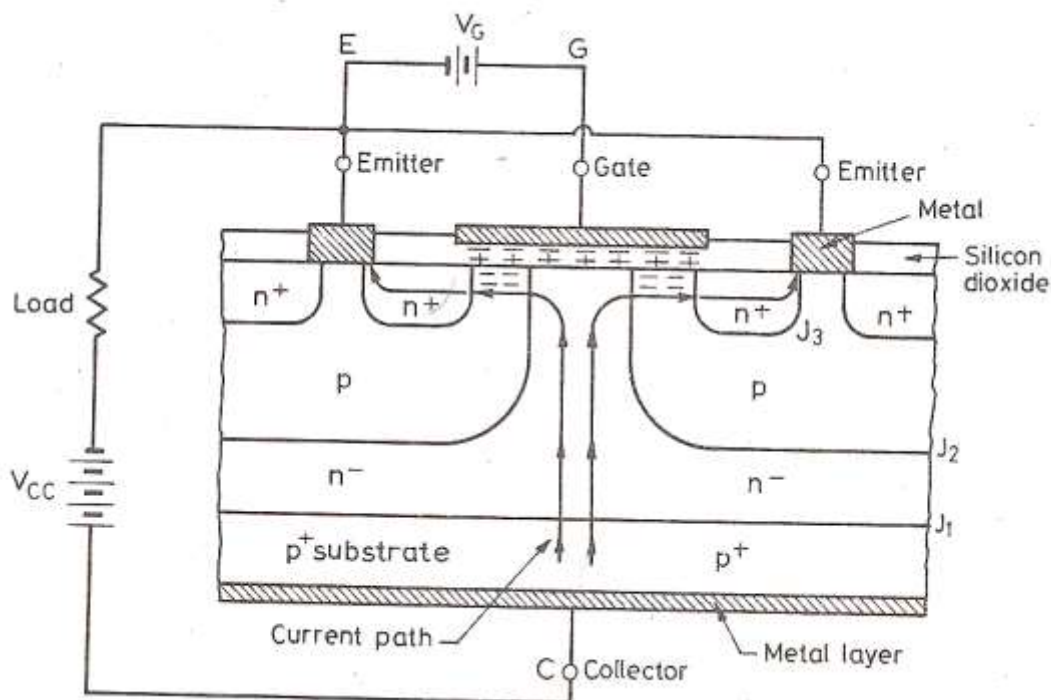

2.5. INSULATED GATE BIPOLAR TRANSISTOR (IGBT)

IGBT is a new development in the area of power MOSFET technology. This device combines into it the advantages of both MOSFET and BJT. So an IGBT has high input impedance like a MOSFET and low-on-state power loss as in a BJT. Further, IGBT is free from second breakdown problem present in BJT. IGBT is also known as metal-oxide insulated gate transistor (MOSIGT), conductively-modulated field effect transistor (COMFET) or gain-modulated FET (GEMFET). It was also initially called insulated gate transistor (IGT).

2.5.1. Basic Structure and Working

Fig. 2.16 illustrates the basic structure of an IGBT. It is constructed virtually in the same manner as a power MOSFET. There is, however, a major difference in the substrate. The n^+ layer substrate at the drain in a power MOSFET is now substituted in the IGBT by a p^+ layer substrate called collector. Like a power MOSFET, an IGBT has also thousands of basic structure cells connected appropriately on a single chip of silicon.

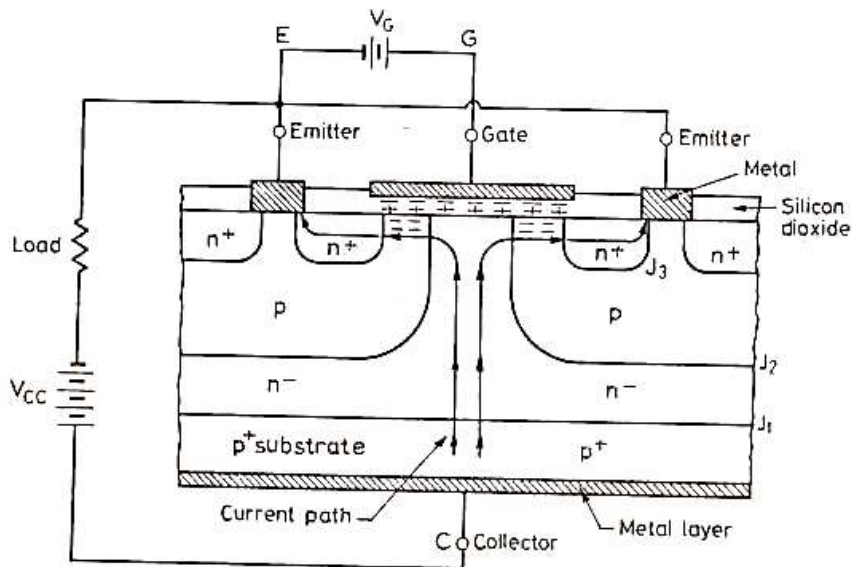

Fig. 2.16. Basic structure of an insulated gate bipolar transistor (IGBT).

When gate is positive with respect to emitter and with gate-emitter voltage more than the threshold voltage of IGBT, an n -channel is formed in the p -regions as in a power MOSFET, Fig. 2.16. This n -channel short circuits the n^- region with n^+ emitter regions. An electron

movement in the n -channel, in turn, causes substantial hole injection from p^+ substrate layer into the epitaxial n^- layer. Eventually, a forward current is established as shown in Fig. 2.16.

The three layers p^+ , n^- and p constitute a pn p transistor with p^+ as emitter, n^- as base and p as collector. Also n^- , p and n^+ layers constitute npn transistor as shown in Fig. 2.17 (a). Here n^- serves as base for pn p transistor and also as collector for npn transistor. Further,

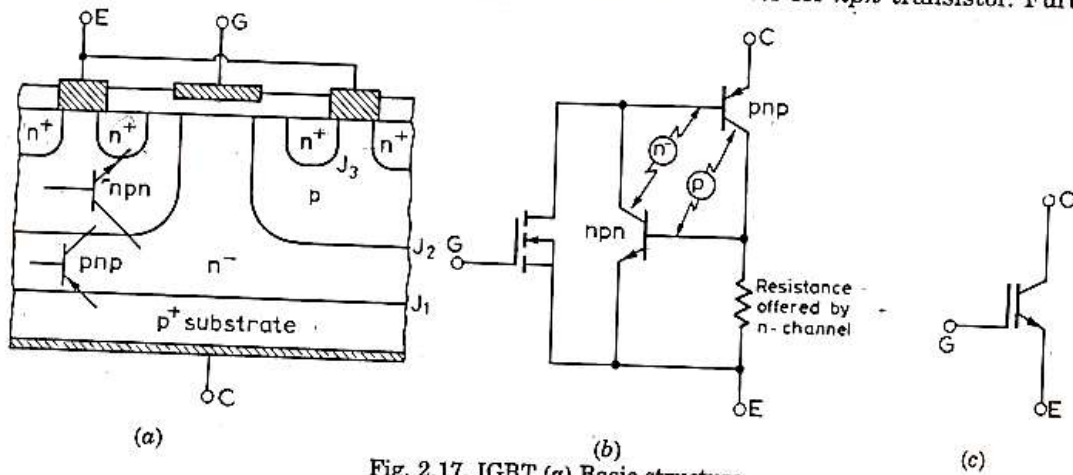

Fig. 2.17. IGBT (a) Basic structure, (b) its equivalent circuit and (c) its circuit symbol.

p serves as collector for pn p device and also as base for npn transistor. The two pn p and npn transistors can, therefore, be connected as shown in Fig. 2.17 (b) to give the equivalent circuit of an IGBT. Fig. 2.17 (c) is the circuit symbol for IGBT with gate (G), emitter (E) and collector (C) as its three terminals.

IGBT has high input impedance like MOFSET and low on state power loss as in BJT.

IGBT Characteristics:

Here the controlling parameter is gate emitter voltage As IGBT is a voltage controlled

device. When is less than that is gate emitter threshold voltage IGBT is in off state.

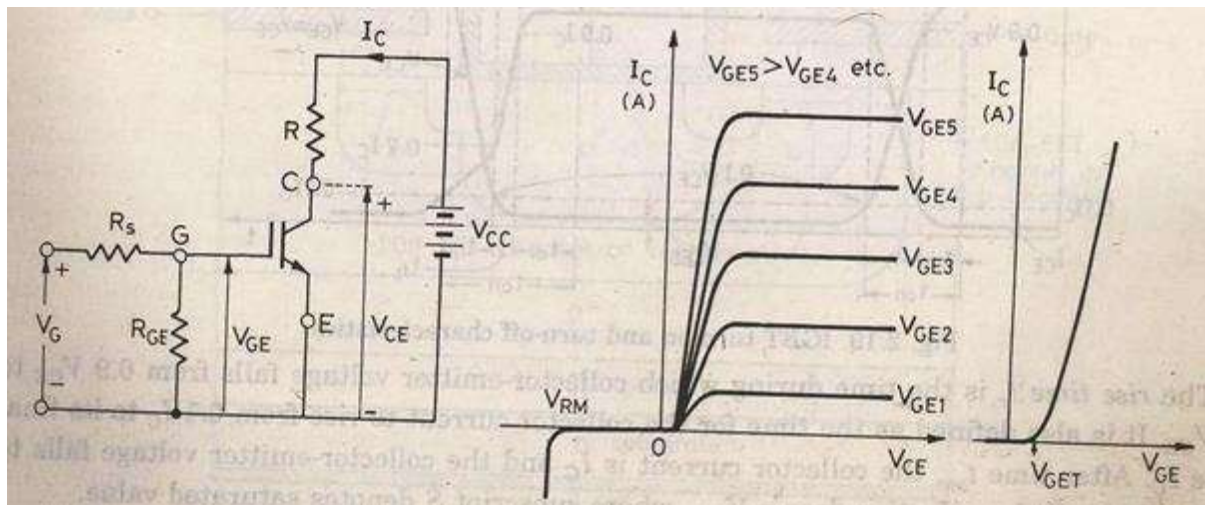

Switching characteristics:

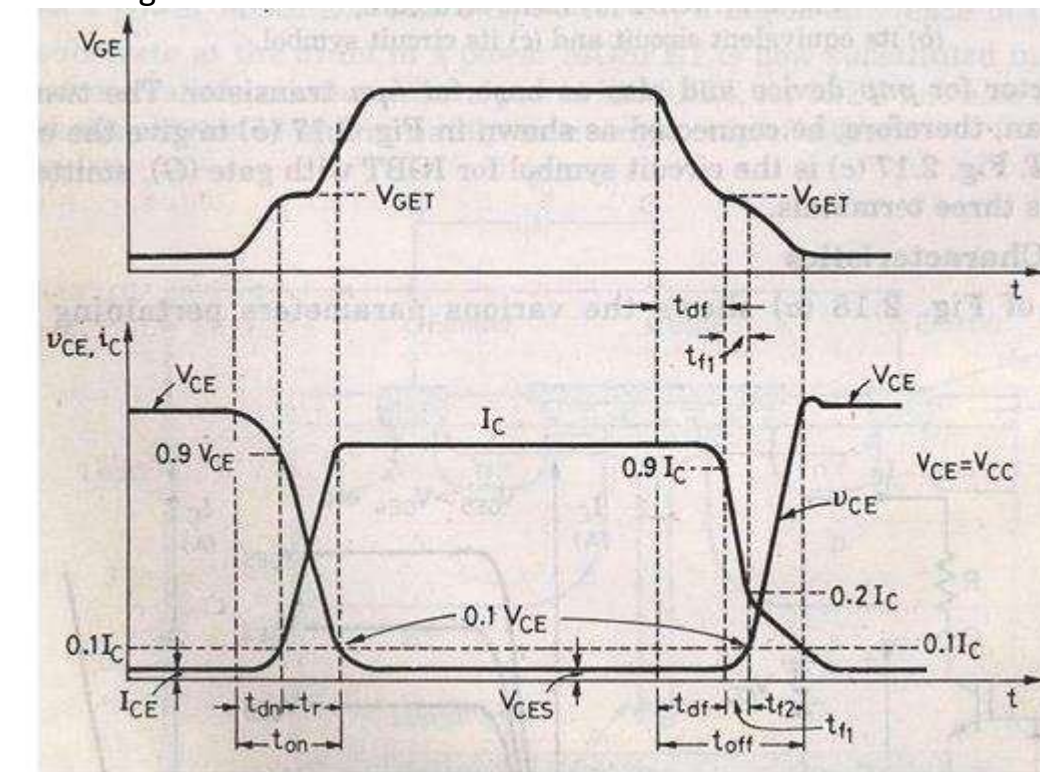

Turn on time

Time between the instants forward blocking state to forward on -state.

Turn on time = Delay time + Rise time

Delay time = Time for collector emitter voltage fall from V_{ce} to $0.9 V_{ce}$

= collector current to rise from initial leakage current to $0.1 I_c$

I_c = Final value of collector current.

Rise time

Collector emitter voltage to fall from 0.9 to 0.1

I_c rises from $0.1 I_c$ to I_c .

After the device is on state the device carries a steady current of I_c and the collector emitter voltage falls to a small value called conduction drop .

Turn off time

1) Delay time

2) Initial fall time 1

3) Final fall time 2

Collector current falls from I_c to $0.9I_c$ at the end of the collector emitter voltage begins to rise.

Turn off time = Collector current falls from 90% to 20% of its initial value I_c OR
The time during which collector emitter voltage rise from to 0.1.

SCR (THYRISTOR)

Thyristor is a four layer three junction p-n-p-n semiconductor switching device. It has 3 terminals these are anode, cathode and gate. SCRs are solid state device, so they are compact, possess high reliability and have low loss.

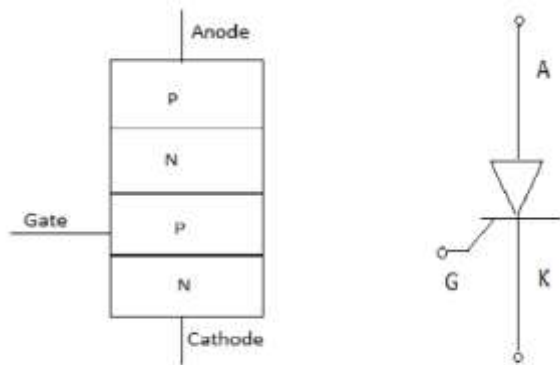

SCR is made up of silicon, it acts as a rectifier; it has very low resistance in the forward direction and high resistance in the reverse direction. It is a unidirectional device.

Static V-I characteristics of a Thyristor:

The circuit diagram for obtaining static V-I characteristics is as shown

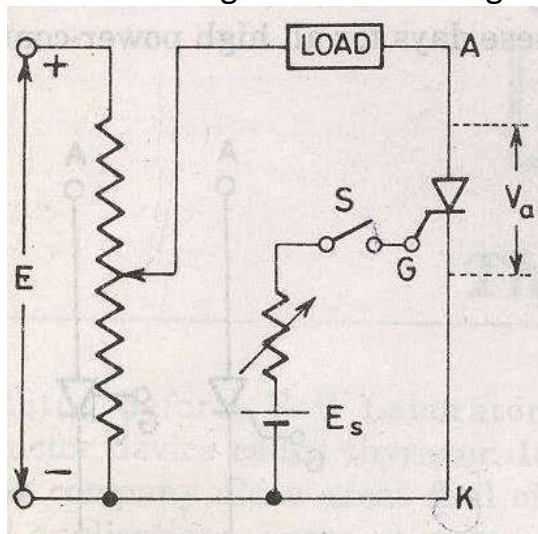

Anode and cathode are connected to main source voltage through the load.
The gate

and cathode are fed from source.

A typical SCR V-I characteristic is as shown below:

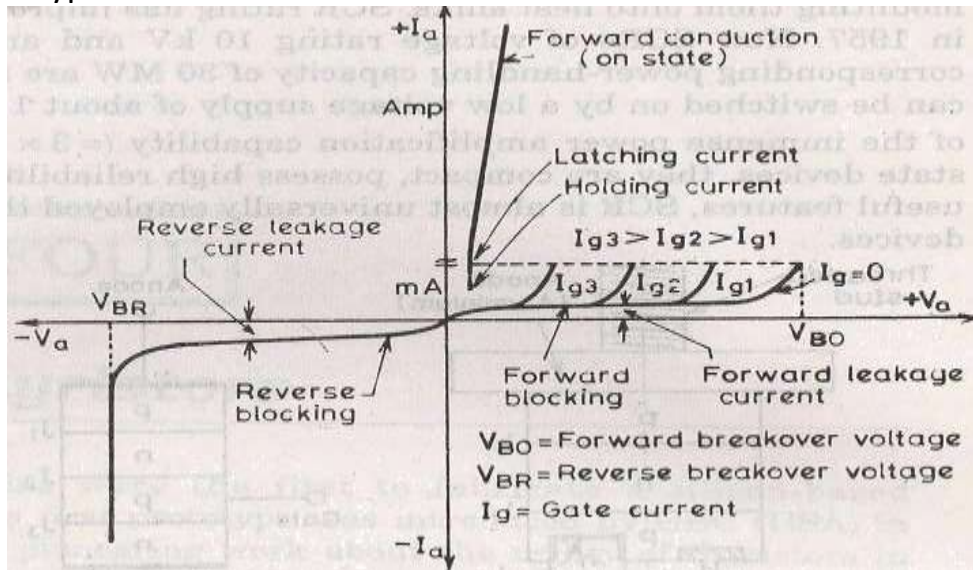

V_{BO} =Forward breakover voltage

V_{BR} =Reverse breakover voltage

I_g =Gate current

V_a =Anode voltage across the thyristor terminal A,K.

I_a =Anode current

A **thyristor** is normally four layer three-terminal device. Four layers are formed by alternating n-type semiconductor and p-type semiconductor materials. Consequently there are three pn junctions formed in the device. It is a bistable device. The three terminals of this device are called anode (A), cathode (K) and gate (G) respectively. The gate (G) terminal is control terminal of the device. That means, the current flowing through the device is controlled by electrical signal applied to the gate (G) terminal. The anode (A) and cathode (K) are the power terminals of the device handle the large applied voltage and conduct the major current through the thyristor. The main difference of thyristors with other digital and electronics switches is that, a thyristor can handle large current and can withstand large voltage, whereas other digital and electronic switches handle only tiny current and tiny voltage.

TYPES OF THYRISTORS

There are four major **types of thyristors**:

1. Silicon Controlled Rectifier (SCR)
2. Gate Turn-off Thyristor (GTO) and Integrated Gate Commutated Thyristor (IGCT)
3. MOS-Controlled Thyristor (MCT)
4. Static Induction Thyristor (SITh).

What is Thyristor or SCR?

It is a silicon based semiconductor device, which is used in electrical circuits for switching operation. **SCR**, whose full form is **silicon controlled rectifier**, is also a well-known member of thyristor family. Although there are many different members available in thyristor family, but **silicon controlled rectifiers** are so widely used that as if thyristor and **SCR** become synonymous. The characteristic of thyristor consists of the characteristic of thyatron tube and characteristic of transistor. The name of thyristor consists of first four letters of thyatron tube and last five letters of transistor. [THYRltron + transISTOR]. The device has ideal states, i.e. On and OFF. Generally an SCR consists of two PN junctions, but sometimes it may also consist of more than two PN junctions. It is four-layer (PNPN) three terminals (Anode, Cathode, Gate) semi-controlled device. This device has two states i.e. on and OFF. We can turn it ON by sending a gate current signal between second P layer and cathode.

STRUCTURE:

Thyristor is a four layer, three-junction, p-n-p-n semiconductor switching device. It has three terminals; anode, cathode and gate. Fig. (a) gives constructional details of a typical thyristor. Basically, a thyristor consists of four layers of alternate p-type and n-type silicon semiconductors forming three junctions J1, J2 and J3 as shown in Fig. (a). The threaded portion is for the purpose of tightening the thyristor to the frame or heat sink with the help of a nut. Gate terminal is usually kept near the cathode terminal Fig.(a). Schematic diagram and circuit symbol for a thyristor are shown respectively in Figs. (b) and (c). The terminal connected to outer p region is called anode (A), the terminal connected to outer n region is called cathode and that connected to inner p region is called the gate (G). For large current applications, thyristors need

better cooling ; this is achieved to a great extent by mounting them onto heat sinks.

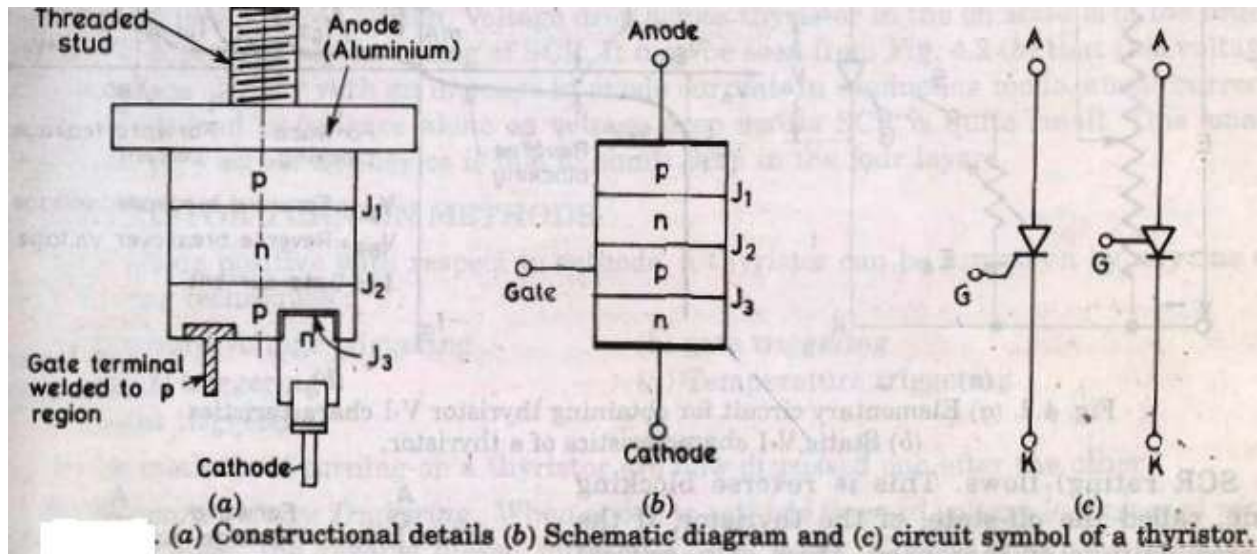

An SCR is so called because silicon is used for its construction and its operation as a rectifier (very low resistance in the forward conduction and very high resistance in the reverse direction) can be controlled. Like the diode, an SCR is an unidirectional device that blocks the current flow from cathode to anode. Unlike the diode, a thyristor also blocks the current flow from anode to cathode until it is triggered into conduction by a proper gate signal between gate and cathode terminals.

STATIC V-I CHARACTERISTICS OF A THYRISTOR

The symbolic diagram and the basic circuit diagram for determining the **characteristics of thyristor** is shown in the figure below,

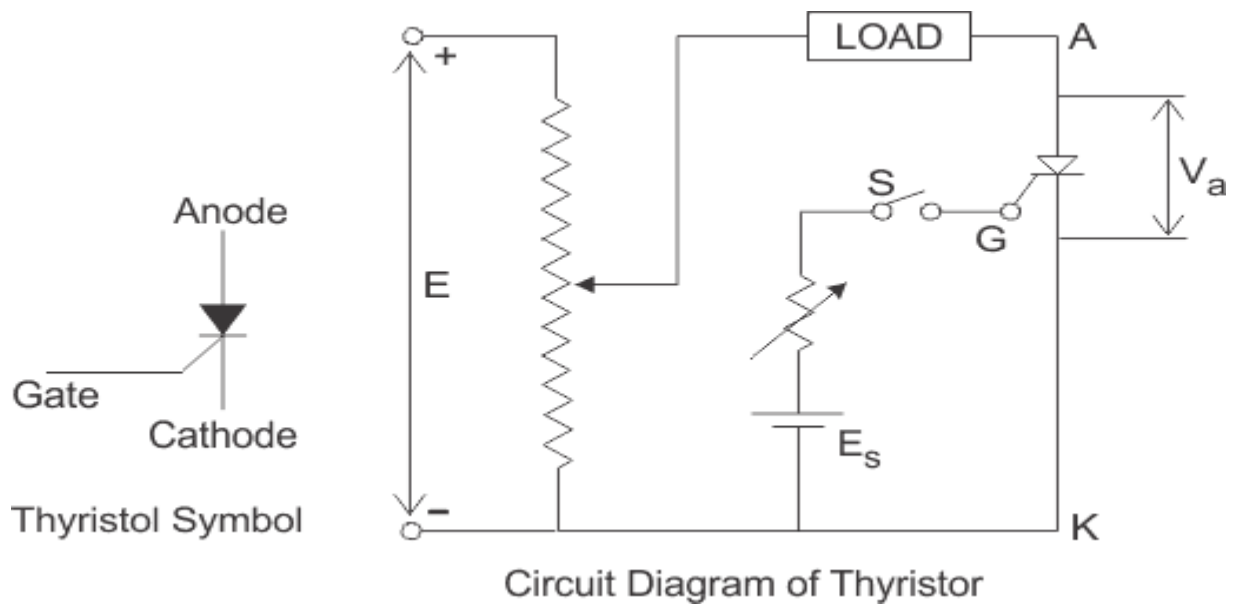

From the circuit diagram, the anode and cathode are connected to the supply voltage through the load. Another secondary supply E_s is applied between the gate and the cathode terminal which supplies for the positive gate current when the switch S is closed. On giving the supply we get the required **V-I characteristics of a thyristor** show in the figure

Anode to cathode voltage V_a and anode current I_a . The thyristor has three basic modes of operation, namely the reverse blocking mode, forward blocking (off-state) mode and forward conduction (on-state) mode.

Reverse Blocking Mode of Thyristor

Initially for the **reverse blocking mode of the thyristor**, the cathode is made positive with respect to anode by supplying voltage E and the gate to cathode supply voltage E_s is detached initially by keeping switch S open.

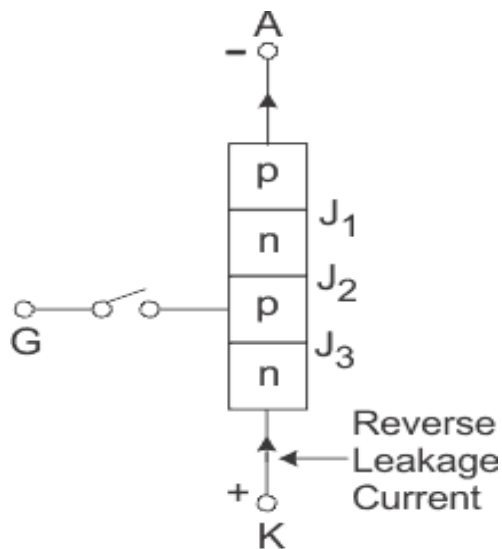

Reverse Blocking Mode

Here Junctions J_1 and J_3 are reverse biased whereas the junction J_2 is forward biased. The behavior of the thyristor here is similar to that of two diodes are connected in series with reverse voltage applied across them. As a result only a small leakage current of the order of a few μAmps flows.

This is the reverse blocking mode or the off-state, of the thyristor. If the reverse voltage is now increased, then at a particular voltage, known as the critical breakdown voltage V_{BR} , an avalanche occurs at J_1 and J_3 and the reverse current increases rapidly. A large current associated with V_{BR} gives rise to more losses in the SCR, which results in heating. This may lead to thyristor damage as the junction temperature may exceed its permissible temperature rise.

The maximum working reverse voltage across a thyristor does not exceed V_{BR} . When reverse voltage applied across a thyristor is less than V_{BR} , the device offers very high impedance in the reverse direction. The SCR in the reverse blocking mode may therefore be treated as open circuit.

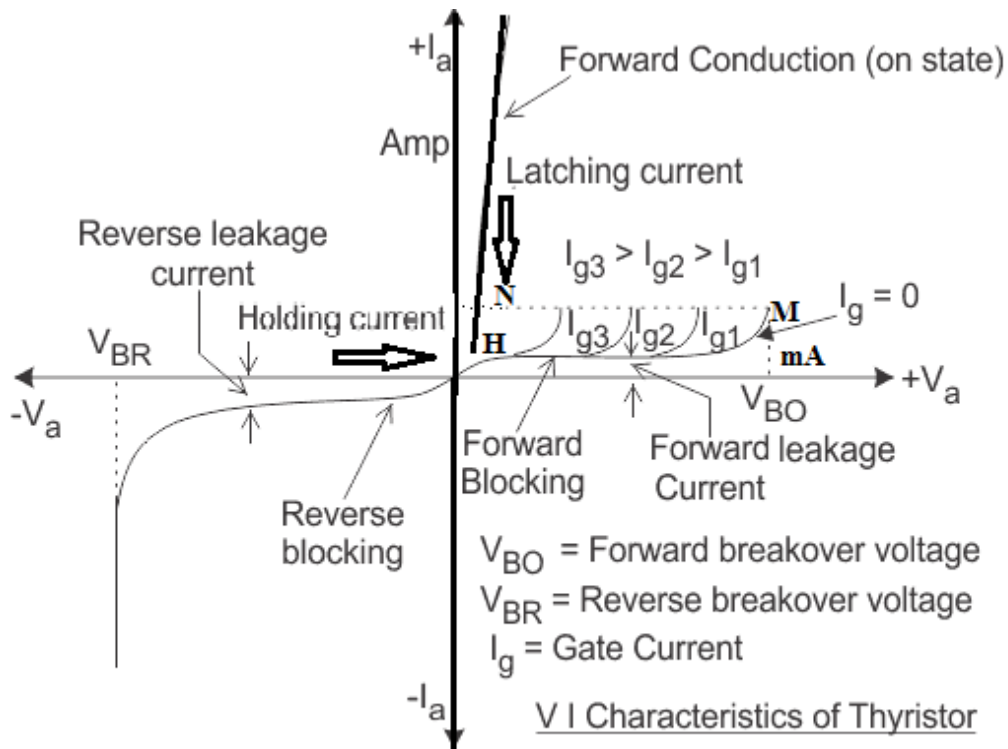

Forward Blocking Mode

When the anode is positive with respect to the cathode, with gate kept in open condition. The thyristor is said to be forward biased as shown the figure .

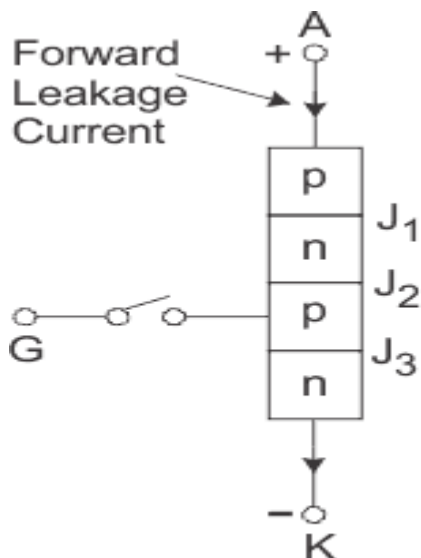

Forward Biased Condition

Junctions J_1 and J_3 are forward biased but junction J_2 goes into reverse biased condition. In this particular mode, a small current, called forward leakage

current is allowed to flow initially as shown in the diagram for characteristics of thyristor. if we keep on increasing the forward biased anode to cathode voltage.

In this particular mode, the thyristor conducts currents from anode to cathode with a very small voltage drop across it. A thyristor is brought from forward blocking mode to forward conduction mode by turning it on by exceeding the forward break over voltage or by applying a gate pulse between gate and cathode. In this mode, thyristor is in on-state and behaves like a closed switch. Voltage drop across thyristor in the on state is of the order of 1 to 2 V depending beyond a certain point, then the reverse biased junction J_2 will have an avalanche breakdown at a voltage called forward break over voltage V_{BO} of the thyristor. But, if we keep the forward voltage less than V_{BO} , we can see from the characteristics of thyristor, that the device offers a high impedance. Thus even here the thyristor operates as an open switch during the forward blocking mode.

Forward Conduction Mode

When the anode to cathode forward voltage is increased, with gate circuit open, the reverse junction J_2 will have an avalanche breakdown at forward break over voltage V_{BO} leading to thyristor turn on. Once the thyristor is turned on we can see from the diagram for **characteristics of thyristor**, that the point M at once shifts toward N and then anywhere between N and K. Here NK represents the forward conduction mode of the thyristor. In this mode of operation, the thyristor conducts maximum current with minimum voltage drop, this is known as the forward conduction forward conduction or the turn on mode of the thyristor.

DIAC

A DIAC is a diode that conducts electrical current only after its breakover voltage (V_{BO}) has been reached. DIAC stands for “Diode for Alternating Current”. A DIAC is a device which has two electrodes, and it is a member of the thyristor family. DIACs are used in the triggering of thyristors. The figure below shows a symbol of a DIAC, which resembles the connection of two diodes in series. DIACs have no gate electrode, unlike some other thyristors that they are commonly used to trigger, such as a TRIAC.

The advantage of a DIAC is that it can be turned on or off simply by reducing the voltage level below its avalanche breakdown voltage. DIACs are also known as a transistor without a base. It should also be noted that a DIAC can be either turned

on or off for both polarities of voltage (i.e. positive or negative voltage). They also still works when avalanche breakdown occurs.

Application of DIAC

The main application of a DIAC is its use in a TRIAC triggering circuit. The DIAC is connected to the gate terminal of the TRIAC. When the voltage across the gate decreases below a predetermined value, the gate voltage will be zero and hence the TRIAC will be turned off.

Some other applications of a DIAC include:

1. It can be used in the lamp dimmer circuit
2. It is used in a heat control circuit
3. It is used in the speed control of a universal motor

Construction of DIAC

It is a device which consists of four layers and two terminals. The construction is almost the same as that of the transistor. But there are certain points which deviate from the construction from the transistor. The differentiating points are-

1. There is no base terminal in the DIAC
2. The three regions have almost the same level of doping
3. It gives symmetrical switching characteristics for either polarity of voltages

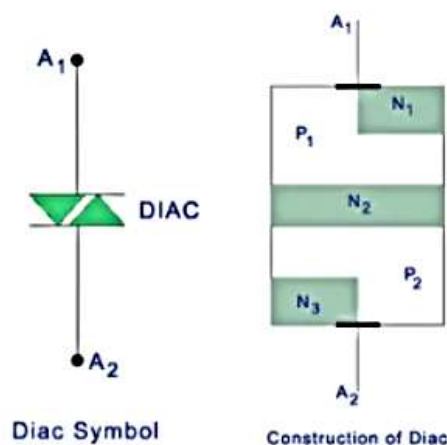

The DIAC can be turned on for both the polarity of voltages. When A₂ is more positive with respect to A₁ then the current does not flow through the corresponding N-layer but flows from P₂-N₂-P₁-N₁. When A₁ is more positive A₂ then the current flows through P₁-N₂-P₂-N₃.

The construction resembles the diode connected in series. When the applied voltage is small in either polarity, a very small current flows which is known as leakage current because of the drift of electrons and holes in the depletion

region. Although a small current flows, it is not sufficient to produce avalanche breakdown, hence the device remains in the non-conducting state.

When the applied voltage in either polarity exceeds the breakdown voltage, DIAC current rises and the device conducts in accordance with its V-I characteristics.

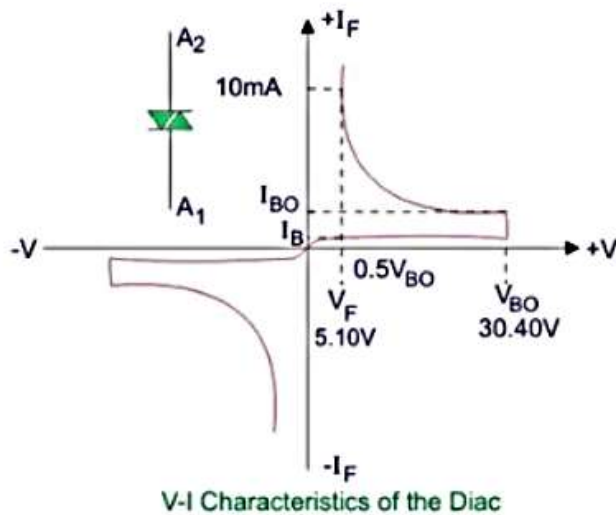

TRIAC

Triac is a three terminal AC switch which is different from the other silicon controlled rectifiers in the sense that it can conduct in both the directions that is whether the applied gate signal is positive or negative, it will conduct. Thus, this device can be used for AC systems as a switch.

This is a three terminal, four layer, bi-directional semiconductor device that controls AC power. The triac of maximum rating of 16 kw is available in the market.

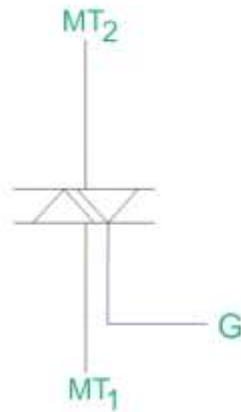

Figure shows the symbol of triac, which has two main terminals MT1 and MT2 connected in inverse parallel and a gate terminal.

Construction of Triac

Two SCRs are connected in inverse parallel with gate terminal as common. Gate terminals is connected to both the N and P regions due to which gate signal may be applied which is irrespective of the polarity of the signal. Here, we do not have anode and cathode since it works for both the polarities which means that device is bilateral. It consists of three terminals namely, main terminal 1(MT1), main terminal 2(MT2), and gate terminal G.

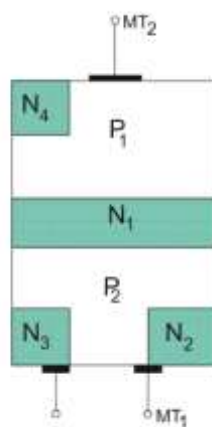

Figure shows the construction of a triac. There are two main terminals namely MT1 and MT2 and the remaining terminal is gate terminal.

Operation of Triac

The triac can be turned on by applying the gate voltage higher than break over voltage. However, without making the voltage high, it can be turned on by applying the gate pulse of 35 micro seconds to turn it on. When the voltage applied is less than the break over voltage, we use gate triggering method to turn it on.

There are four different modes of operations, they are-

1. When MT2 and Gate being Positive with Respect to MT1 When this happens, current flows through the path P1-N1-P2-N2. Here, P1-N1 and P2-N2 are forward biased but N1-P2 is reverse biased. The triac is said to be operated in positively biased region. Positive gate with respect to MT1 forward biases P2-N2 and breakdown occurs.
2. When MT2 is Positive but Gate is Negative with Respect to MT1 The current flows through the path P1-N1-P2-N2. But P2-N3 is forward biased and current carriers injected into P2 on the triac.
3. When MT2 and Gate are Negative with Respect to MT1 Current flows through the path P2-N1-P1-N4. Two junctions P2-N1 and P1-N4 are forward biased but the junction N1-P1 is reverse biased. The triac is said to be in the negatively biased region.
4. When MT2 is Negative but Gate is Positive with Respect to MT1 P2-N2 is forward biased at that condition. Current carriers are injected so the triac turns on. This mode of operation has a disadvantage that it should not be used for high (di/dt) circuits. Sensitivity of triggering in mode 2 and 3 is high and if marginal triggering capability is required, negative gate pulses should be used. Triggering in mode 1 is more sensitive than mode 2 and mode 3.

Characteristics of a Triac

The triac characteristics is similar to SCR but it is applicable to both positive and negative triac voltages. The operation can be summarized as follows-

First Quadrant Operation of Triac

Voltage at terminal MT2 is positive with respect to terminal MT1 and gate voltage is also positive with respect to first terminal.

Second Quadrant Operation of Triac

Voltage at terminal 2 is positive with respect to terminal 1 and gate voltage is negative with respect to terminal 1.

Third Quadrant Operation of Triac

Voltage of terminal 1 is positive with respect to terminal 2 and the gate voltage is negative.

Fourth Quadrant Operation of Triac

Voltage of terminal 2 is negative with respect to terminal 1 and gate voltage is positive.

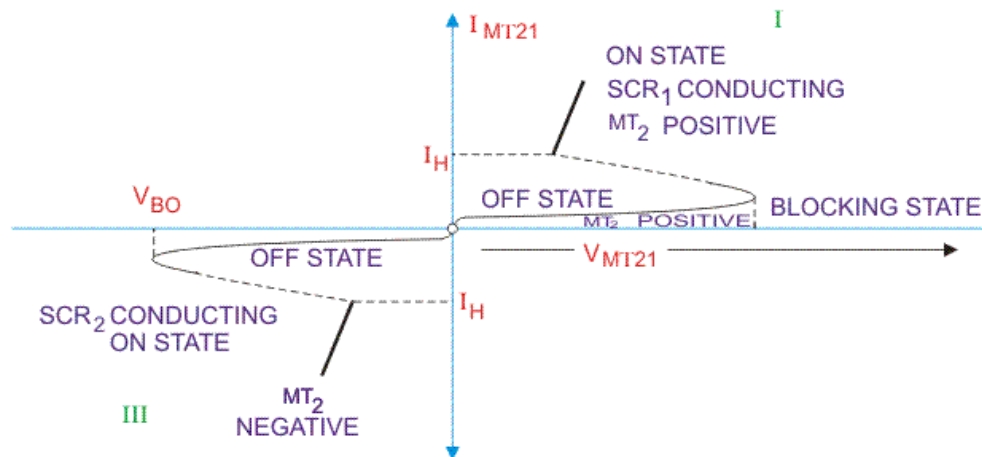

V-I Characteristic of a Triac

When the device gets turned on, a heavy current flows through it which may damage the device, hence in order to limit the current a current limiting resistor should be connected externally to it. By applying proper gate signal, firing angle of the device may be controlled. The gate triggering circuits should be used for proper gate triggering. We can use diac for triggering the gate pulse. For firing of the device with proper firing angle, a gate pulse may be applied up to a duration of 35 micro seconds.

Advantages of Triac

- It can be triggered with positive or negative polarity of gate pulses.
- It requires only a single heat sink of slightly larger size, whereas for SCR, two heat sinks should be required of smaller size.
- It requires single fuse for protection.

- A safe breakdown in either direction is possible but for SCR protection should be given with parallel diode.

Disadvantages of Triac

- They are not much reliable compared to SCR.
- It has (dv/dt) rating lower than SCR.
- Lower ratings are available compared to SCR.
- We need to be careful about the triggering circuit as it can be triggered in either direction.

Uses of Triac

- They are used in control circuits.
- It is used in High power lamp switching.
- It is used in AC power control.

GTO

- A gate turn-off thyristor (GTO) is a special type of thyristor, which is a high-power semiconductor device. It was invented at General Electric. GTOs, as opposed to normal thyristors, are fully controllable switches which can be turned on and off by their third lead, the gate lead.
- Normal thyristors (silicon-controlled rectifiers) are not fully controllable switches (a "fully controllable switch" can be turned on and off at will). Thyristors can only be turned ON using the gate lead, but cannot be turned OFF using the gate lead. Thyristors are switched ON by a gate signal, but even after the gate signal is de-asserted (removed), the thyristor remains in the ON-state until a turn-off condition occurs (which can be the application of a reverse voltage to the terminals, or a decrease of the forward current below a certain threshold value known as the "holding current"). Thus, a thyristor behaves like a normal semiconductor diode after it is turned on or "fired".
- The GTO can be turned on by a gate signal, and can also be turned off by a gate signal of negative polarity.
- Turn on is accomplished by a "positive current" pulse between the gate and cathode terminals. As the gate-cathode behaves like PN junction, there will be some relatively small voltage between the terminals. The turn on phenomenon in GTO is however, not as reliable as an SCR

(thyristor) and small positive gate current must be maintained even after turn on to improve reliability.

- Turn off is accomplished by a "negative voltage" pulse between the gate and cathode terminals. Some of the forward current (about one-third to one-fifth) is "stolen" and used to induce a cathode-gate voltage which in turn causes the forward current to fall and the GTO will switch off (transitioning to the 'blocking' state.)
- GTO thyristors suffer from long switch off times, whereby after the forward current falls, there is a long tail time where residual current continues to flow until all remaining charge from the device is taken away. This restricts the maximum switching frequency to approx 1 kHz. It may be noted however, that the turn off time of a GTO is approximately ten times faster than that of a comparable SCR.
- To assist with the turn-off process, GTO thyristors are usually constructed from a large number (hundreds or thousands) of small thyristor cells connected in parallel.

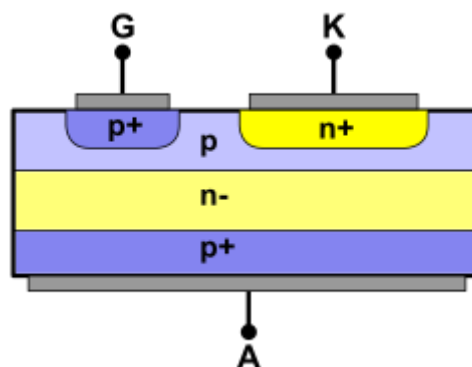

Simplified cross section of a GTO thyristor

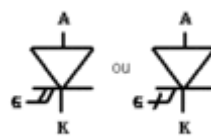

Electronic symbol

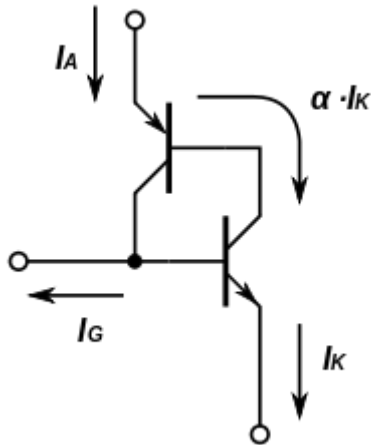

Equivalent circuit of a GTO thyristor

Characteristic	Description	Thyristor (1600 V, 350 A)	GTO (1600 V, 350 A)
$V_{T\text{ON}}$	On state voltage drop	1.5 V	3.4 V
$t_{\text{on}}, I_{G\text{on}}$	Turn on time, gate current	8 μs , 200 mA	2 μs , 2 A
t_{off}	Turn off time	150 μs	15 μs

Comparison of an SCR and GTO of same rating.

- A distributed buffer gate turn-off thyristor (DB-GTO) is a thyristor with additional PN layers in the drift region to reshape the field profile and increase the voltage blocked in the off state. Compared to a typical PNPN structure of a conventional thyristor, this thyristor would be a PN-PN-PN type structure in here.

Reverse bias

- GTO thyristors are available with or without reverse blocking capability. Reverse blocking capability adds to the forward voltage drop because of the need to have a long, low doped P1 region.

- GTO thyristors capable of blocking reverse voltage are known as Symmetrical GTO thyristors, abbreviated S-GTO. Usually, the reverse blocking voltage rating and forward blocking voltage rating are the same. The typical application for symmetrical GTO thyristors is in current source inverters.
- GTO thyristors incapable of blocking reverse voltage are known as asymmetrical GTO thyristors, abbreviated A-GTO, and are generally more common than Symmetrical GTO thyristors. They typically have a reverse breakdown rating in the tens of volts. A-GTO thyristors are used where either a reverse conducting diode is applied in parallel (for example, in voltage source inverters) or where reverse voltage would never occur (for example, in switching power supplies or DC traction choppers).
- GTO thyristors can be fabricated with a reverse conducting diode in the same package. These are known as RCGTO, for Reverse Conducting GTO thyristor.

Safe operating area

- Unlike the insulated gate bipolar transistor (IGBT), the GTO thyristor requires external devices ("snubber circuits") to shape the turn on and turn off currents to prevent device destruction.
- During turn on, the device has a maximum di/dt rating limiting the rise of current. This is to allow the entire bulk of the device to reach turn on before full current is reached. If this rating is exceeded, the area of the device nearest the gate contacts will overheat and melt from over current. The rate of di/dt is usually controlled by adding a saturable reactor (turn-on snubber), although turn-on di/dt is a less serious constraint with GTO thyristors than it is with normal thyristors, because of the way the GTO is constructed from many small thyristor cells in parallel. Reset of the saturable reactor usually places a minimum off time requirement on GTO based circuits.
- During turn off, the forward voltage of the device must be limited until the current tails off. The limit is usually around 20% of the forward blocking voltage rating. If the voltage rises too fast at turn off, not all of the device will turn off and the GTO will fail, often explosively, due to the high voltage and current focused on a small portion of the device. Substantial snubber circuits are added around the device to limit the rise

of voltage at turn off. Resetting the snubber circuit usually places a minimum on time requirement on GTO based circuits.

- The minimum on and off time is handled in DC motor chopper circuits by using a variable switching frequency at the lowest and highest duty cycle. This is observable in traction applications where the frequency will ramp up as the motor starts, then the frequency stays constant over most of the speed ranges, then the frequency drops back down to zero at full speed.

Applications

- The main applications are in variable speed motor drives, high power inverters and traction. GTOs are increasingly being replaced by integrated gate-commutated thyristors, which are an evolutionary development of the GTO, and insulated gate bipolar transistors, which are members of the transistor family.

1.2 Two Transistor Model of SCR

Basic operating principle of SCR, can be easily understood by the **two transistor model of SCR** or analogy of silicon controlled rectifier, as it is also a combination of P and N layers, shown in figure below.

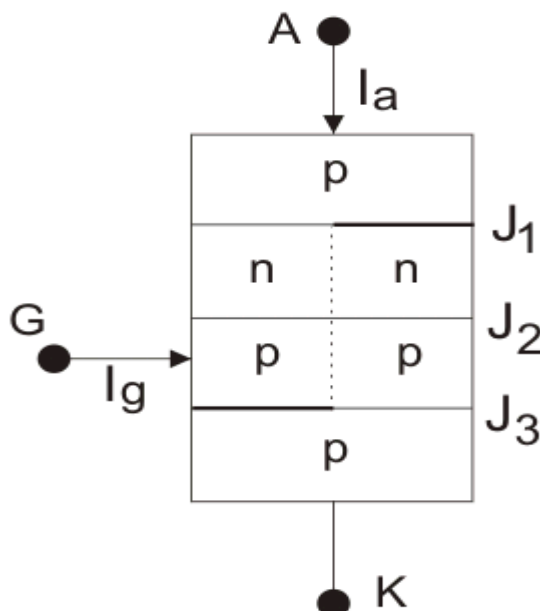

This is a pnpn thyristor. If we bisect it through the dotted line then we will get two transistors i.e. one pnp transistor with J₁ and J₂ junctions and another is with J₂ and J₃ junctions as shown in figure below.

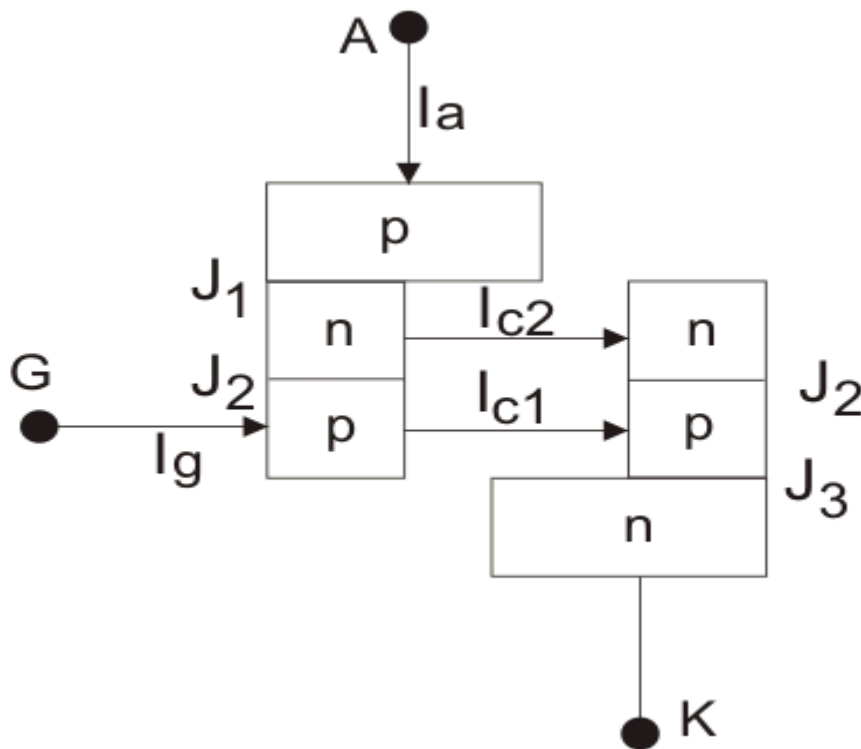

When the transistors are in off state, the relation between the collector current and emitter current is shown below

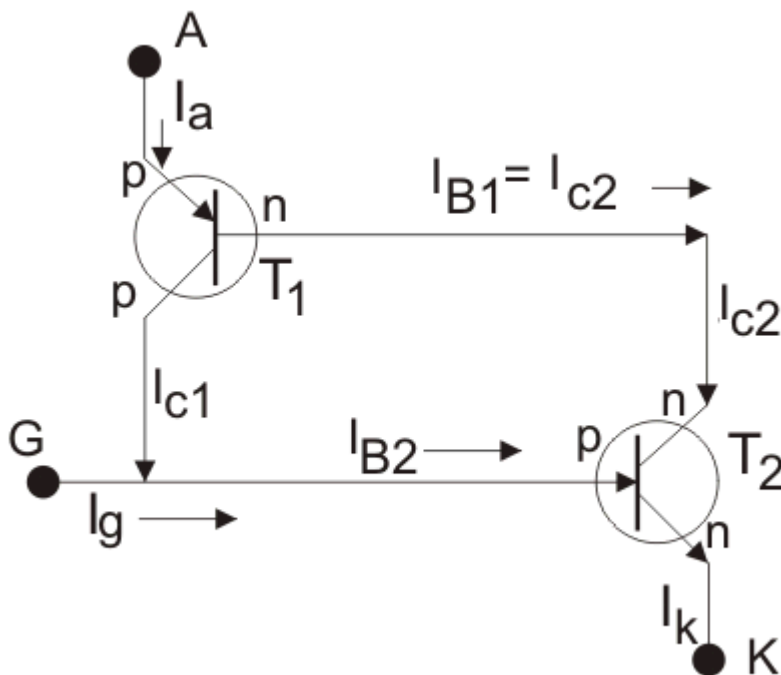

Here, I_C is collector current, I_E is emitter current, I_{CBO} is forward leakage current, α is common base forward current gain and relationship between I_C and I_B is

$$I_C = \beta I_B$$

Where, I_B is base current and β is common emitter forward current gain. Let's for transistor T_1 this relation holds

$$I_{C1} = \alpha_1 I_a + I_{CBO1} \dots (i)$$

And that for transistor T₂

$$I_{C2} = \alpha_2 I_k + I_{CBO2} \dots (ii) \text{ again } I_{C2} = \beta_2 I_{B2}$$

Now, by the analysis of two transistors model we can get anode current,

$$I_a = I_{C1} + I_{C2} \text{ [applying KCL]}$$

From equation (i) and (ii), we get,

$$I_a = \alpha_1 I_a + I_{CBO1} + \alpha_2 I_k + I_{CBO2} \dots (iii)$$

If applied gate current is I_g then cathode current will be the summation of anode current and gate current i.e.

$$I_k = I_a + I_g$$

By substituting this value of I_k in (iii) we get,

$$I_a = \alpha_1 I_a + I_{CBO1} + \alpha_2 (I_a + I_g) + I_{CBO2}$$

$$I_a = \frac{\alpha_2 I_g + I_{CBO1} + I_{CBO2}}{1 - (\alpha_1 + \alpha_2)}$$

From this relation we can assure that with increasing the value of $(\alpha_1 + \alpha_2)$ towards unity, corresponding anode current will increase. Now the question is how $(\alpha_1 + \alpha_2)$ increasing? Here is the explanation using **two transistor model of SCR**. At the first stage when we apply a gate current I_g, it acts as base current of T₂ transistor i.e. I_{B2} = I_g and emitter current i.e.

I_k = I_g of the T₂ transistor. Hence establishment of the emitter current gives rise α_2 as

$$\alpha_2 = \frac{I_{CBO1}}{I_g}$$

Presence of base current will generate collector current as

$$I_{C2} = \beta_2 \times I_{B2} = \beta_2 I_g$$

This I_{C2} is nothing but base current I_{B1} of transistor T₁, which will cause the flow of collector current,

$$I_{C2} = \beta_1 \times I_{B1} = \beta_1 \beta_2 I_g$$

I_{C1} and I_{B1} lead to increase I_{C1} as $I_a = I_{C1} + I_{B1}$ and hence, α_1 increases. Now, new base current of T_2 is $I_g + I_{C1} = (1 + \beta_1 \beta_2) I_g$, which will lead to increase emitter current $I_k = I_a + I_{C1}$ and as a result α_2 also increases and this further increases $I_{C2} = \beta_2 (1 + \beta_1 \beta_2) I_g$. As $I_{B1} = I_{C2}$, α_1 again increases. This continuous positive feedback effect increases $(\alpha_1 + \alpha_2)$ towards unity and anode current tends to flow at a very large value. The value current then can only be controlled by external resistance of the circuit.

Gate Characteristics

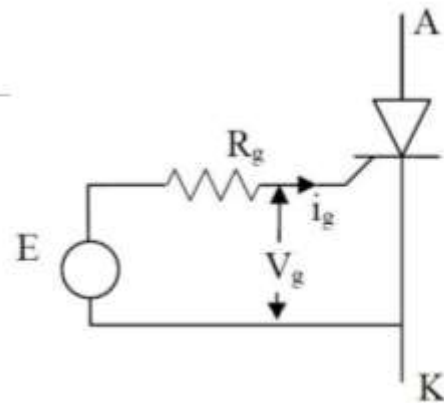
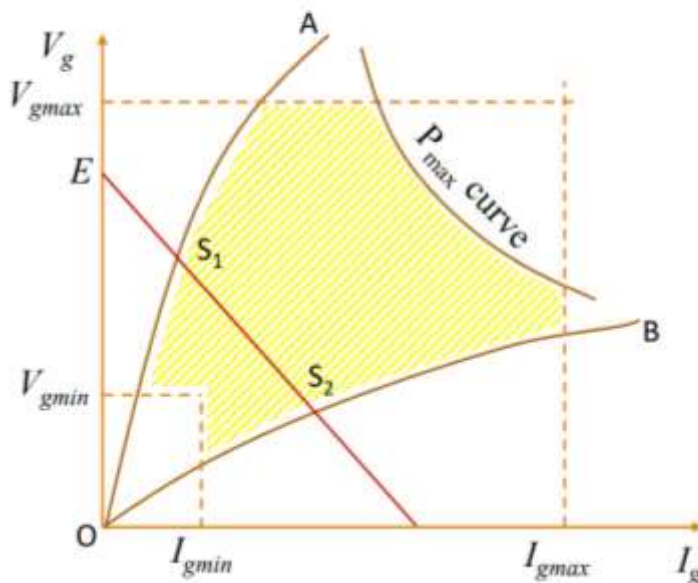

OA and OB represent the spread of characteristics for the thyristor of same rating

1.4 Switching or ON OFF Characteristics of SCR | Turn ON Turn OFF Time

Turn ON Time of SCR

A forward biased thyristor can be turned on by applying a positive voltage between gate and cathode terminal. But it takes some transition time to go from forward blocking mode to forward conduction mode. This transition time is called **turn on time of SCR** and it can be subdivided into three small intervals as delay time (t_d) rise time(t_r), spread time(t_s).

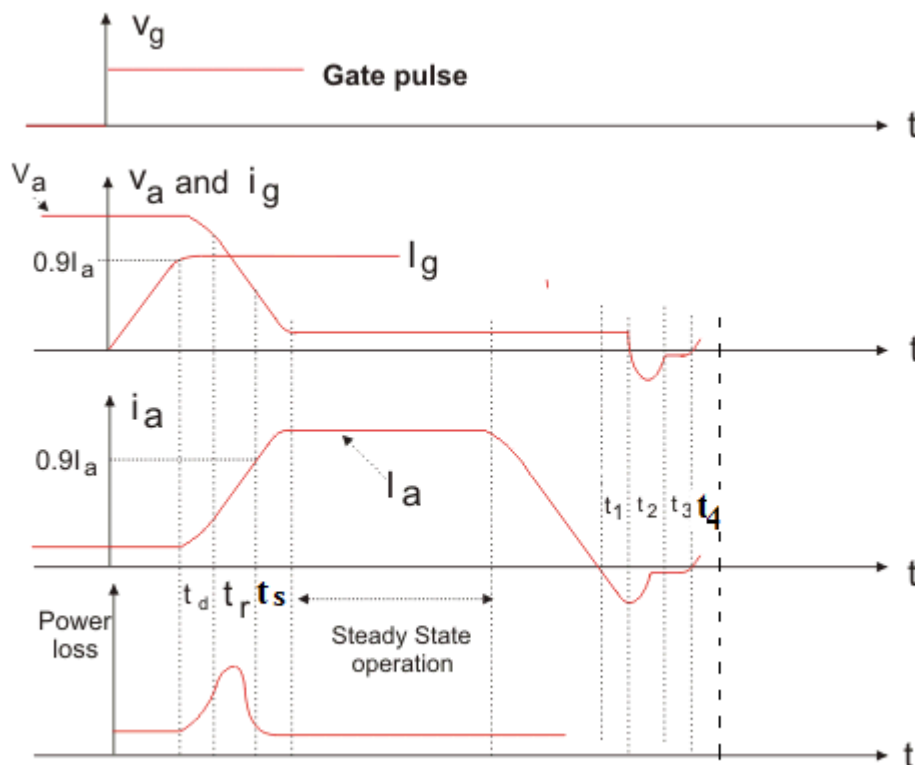

Delay Time of SCR (t_d)

After application of gate current, the thyristor will start conducting over a very tiny region. **Delay time of SCR** can be defined as the time taken by the gate current to increase from 90% to 100% of its final value I_g . From another point of view, **delay time** is the interval in which anode current rises from forward leakage current to 10% of its final value and at the same time anode voltage will fall from 100% to 90% of its initial value V_a .

Rise Time of SCR(t_r)

Rise time of SCR is the time taken by the anode current to rise from 10% to 90% of its final value. At the same time anode voltage will fall from 90% to 10% of its initial value V_a . The phenomenon of decreasing anode voltage and increasing

anode current is entirely dependent upon the type of the load. For example if we connect a inductive load, voltage will fall in a faster rate than the current increasing. This is happened because induction does not allow initially high voltage change through it. On the other hand if we connect a capacitive load it does not allow initial high voltage change through it, hence current increasing rate will be faster than the voltage falling rate.

High increasing rate of di_a/dt can create local hot spot in the device which is not suitable for proper operation. So, it is advisable to use a inductor in series with the device to tackle high di_a/dt . Usually value of maximum allowable di/dt is in the range of 20 to 200 A per microsecond.

Spread Time of SCR(t_s)

It is the time taken by the anode current to rise from 90% to 100% of its final value. At the same time the anode voltage decreases from 10% of its initial value to smallest possible value. In this interval of time conduction spreads all over the area of cathode and the SCR will go to fully ON State. **Spread time of SCR** depends upon the cross-sectional area of cathode.

Turn OFF Time of SCR

Dynamic process of the SCR from conduction state to forward blocking state is called commutation process or turn-off process. Once the thyristor is switched on or in other point of view, the anode current is above latching current, the gate loses control over it. That means gate circuit cannot turn off the device. For turning off the SCR anode current must fall below the holding current. After anode current fall to zero we cannot apply forward voltage across the device due to presence of carrier charges into the four layers. So we must sweep out or recombine these charges to proper **turn off of SCR**. So **turn off time of SCR** can be defined as the interval between anode current falls to zero and device regains its forward blocking mode. On the basis of removing carrier charges from the four layers, **turn off time of SCR** can be divided into two time regions,

1. Reverse Recovery Time. (t_{rr})
2. Gate Recovery Time(t_{gr})

The turn-off time t_q of a thyristor is defined as the time between the instant anode current becomes zero and the instant SCR regains forward blocking capability. During time t_q , all the excess carriers from the four layers of SCR must be removed. This removal of excess carriers consists of sweeping out of holes from outer p-layer and electrons from outer n-layer. The carriers

around junction J₂ can be removed only by recombination. The turn-off time is divided into two intervals ; reverse recovery time t_r ; and the gate recovery time t_{gr} ; i.e.

$$t_q = t_{rr} + t_{gr}$$

Reverse Recovery Time(t_{rr})

It is the interval in which charge carriers remove from J₁, and J₃ junction. At time t_1 , anode current falls to zero and it will continue to increase in reverse direction with same slope (di/dt) of the forward decreasing current. This negative current will help to sweep out the carrier charges from junction J₁ and J₃. At the time t_2 carrier charge density is not sufficient to maintain the reverse current hence after t_2 this negative current will start to decrease. The value of current at t_2 is called reverse recovery current. Due to rapid decreasing of anode current, a reverse spike of voltage may appear across the SCR. Total recovery time $t_3 - t_1$ is called **reverse recovery time**. After that, device will start to follow the applied reverse voltage and it gains the property to block the forward voltage.

Gate Recovery Time(t_{gr})

After sweeping out the carrier charges from junction J₁ and J₃ during **reverse recovery time**, there still remain trapped charges in J₂ junction which prevent the SCR from blocking the forward voltage. These trapped charge can be removed by recombination only and the interval in which this recombination is done, called **gate recovery time**.

The thyristor turn-off time t_q is applicable to an individual SCR. In actual practice, thyristor (or thyristors) form a part of the power circuit. The turn-off time provided to the thyristor by the practical circuit is called circuit turn-off time t_c . It is defined as the time between the instant anode current becomes zero and the instant reverse voltage due to practical circuit reaches zero, see Fig. Time t_c must be greater than t_q for reliable turn-off, otherwise the device may turn-on at an undesired instant, a process called commutation failure.

1.5 THYRISTOR TURN-ON METHODS

With anode positive with respect to cathode, a thyristor can be turned on by any one of the following techniques.

- a) Forward Voltage Triggering
- b) Gate Triggering
- c) dv/dt Triggering:
- d) Temperature Triggering
- e) Light Triggering

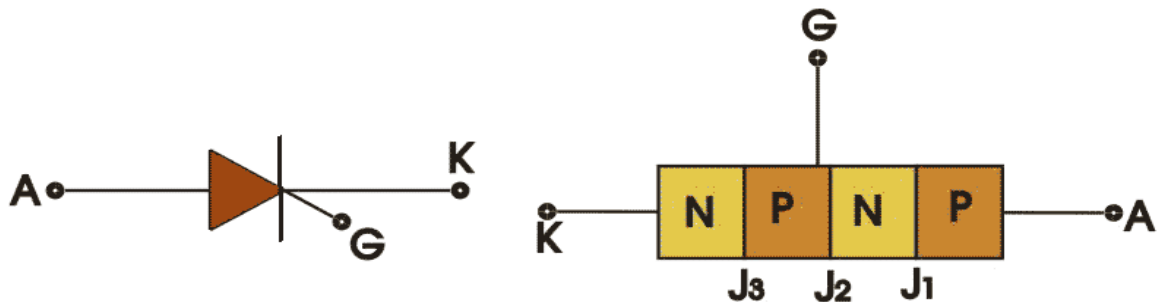

Triggering means turning ON of a device from its off state. Turning ON of a thyristor refers to **thyristor triggering**. Thyristor is turned on by increasing the anode current flowing through it. The increase in anode current can be achieved by many ways.

a). Forward Voltage Triggering :

The applied forward voltage is gradually increased beyond a pt.known as forward break over voltage V_{BO} and gate is kept open. This method is not preferred because during turn on of thyristor, it is associated with large voltage and large current which results in huge power loss and device may be damaged.

When anode to cathode forward voltage is increased with gate circuit open, the reverse biased junction J 2 will break. This is known as avalanche breakdown and the voltage at which avalanche occurs is called forward breakover voltage V_{Bo} . At this voltage, thyristor changes from off-state (high voltage with low leakage current) to on-state characterised by low voltage across thyristor with large forward current. As other junctions J1, J3 are already forward biased, breakdown of junction J2 allows free movement of carriers across three junctions and as a result, large forward anode-current flows. As stated before, this forward current is limited by the load impedance. In practice, the transition from off-state to on-state obtained by exceeding V_{Bo} is never employed as it may destroy the device.

if the anode voltage is reduced below V_{Bo} . SCR will continue conduction of the current. The SCR can now be turned off only by reducing the anode current below a certain value called holding current

(b) Gate Triggering :

Turning on of thyristors by gate triggering is simple, reliable and efficient, it is therefore the most usual method of firing the forward biased SCRs. A thyristor with forward breakover voltage (say 800 V) higher than the normal working voltage (say 400 V) is chosen. This means that thyristor will remain in forward blocking state with normal working voltage across anode and cathode and with gate open. However, when turn-on of a thyristor is required, a positive gate voltage between gate and cathode is applied. With gate current thus established, charges are injected into the inner p layer and voltage at which forward break-over occurs is reduced. The forward voltage at which the device switches to on-state depends upon the magnitude of gate current. Higher the gate current, lower is the forward breakover voltage.

Once the SCR is conducting a forward current, reverse biased junction J_2 no longer exists. As such, no gate current is required for the device to remain in on-state. Therefore, if the gate current is removed, the conduction of current from anode to cathode remains unaffected., if gate current is reduced to zero before the rising anode current attains a value, called the **latching current**, the thyristor will turn-off again. The gate pulse width should therefore be judiciously chosen to ensure that anode current rises above the latching current. **Thus latching current may be defined as the minimum value of anode current which it must attain during turn-on process to maintain conduction when gate signal is removed.** Once the thyristor is conducting, gate loses control. The thyristor can be turned-off (or the thyristor can be returned to forward blocking state) only if the forward current falls below a low-level current called the holding current. **Thus holding current may be defined as the minimum value of anode current below which it must fall for turning-off the thyristor.** The latching current is higher than the holding current.

Latching current is associated with turn-on process and holding current with turn-off process. It is usual to take latching current as two to three times the holding current. In industrial applications, holding current (typically 10 mA) is almost taken as zero

(c) dv/dt Triggering:

In this method of triggering if the applied rate of change of voltage is large, then the device will turn on even though the voltage appearing across the device is small. We know that when SCR is applied with forward voltage across the

anode and cathode, junctions j_1 and j_3 will be in forward bias and junction j_2 will be in reverse bias. This reverse biased junction j_2 will have the characteristics of the capacitor due to the charges exist across the junction. If the forward voltage is suddenly applied a charging current will flow tending to turn on the SCR. This magnitude of the charging current depends on the rate of change of applied voltage.

- i. When the device is forward biased, J_1 and J_3 are forward biased, J_2 is reverse biased.
- ii. Junction J_2 behaves as a capacitor, due to the charges existing across the junction.
- iii. If voltage across the device is V , the charge by Q and capacitance by C then,

$$i_c = dQ/dt$$

$$Q = CV$$

$$i_c = d(CV)/dt$$

$$= C.dV/dt + V.dC/dt$$
 as $dC/dt = 0$

$$i_c = C.dV/dt$$
- iv. Therefore when the rate of change of voltage across the device becomes large, the device may turn ON, even if the voltage across the device is small.

(d) Temperature Triggering :

During forward blocking, most of the applied voltage appears across reverse biased junction J_2 . This voltage across junction J_2 associated with leakage current through junction J_2 further increases. This cumulative process may turn on the SCR at some high temperature.

(e) Light Triggering:

The pulse of light of appropriate wavelength is guided by optical fibres for irradiation. If the intensity of this light thrown on the recess exceeds a certain value, forward-biased SCR is turned on. Such a thyristor is known as light-activated SCR (LASCR).

LASCR may be triggered with a light source or with a gate signal. Sometimes a combination of both light source and gate signal is used to trigger an SCR. For this, the gate is biased with voltage or current slightly less than that required to turn it on, now a beam of light directed at the inner p-layer junction turns on the SCR. The light intensity required to turn-on the SCR depends upon

the voltage bias given to the gate. Higher the voltage (or current) bias, lower the light intensity required. , Light-triggered thyristors used in high-voltage direct current (HVDC) transmission systems. In these several SCRs are connected in series-parallel combination and their light-triggering has the advantage of electrical isolation between power and control circuits.

1.6 SCR Turn OFF Methods

An SCR is said to be 'turned OFF' if there is no flow of forward current and even if the SCR is once again forward biased (positive voltage at anode), the SCR will not conduct without any Gate Signal (using one of the SCR Turn ON Methods).

The reverse voltage, which causes to commutate the SCR, is called the Commutation Voltage. Depending on the type of switching of SCR (Cyclic or Sequential), the commutation methods are classified into two major types. They are:

- Natural Commutation
- Forced Commutation

Before discussing about different types of ACR Turn OFF Methods, there is an important quantity known as the Turn OFF Time of SCR which we have to understand.

Turn OFF Time t_{OFF} of an SCR is the time between the moment anode current becomes zero and the moment SCR starts to block the forward voltage.

Natural Commutation

In natural commutation, the source of commutation voltage is the supply source itself. If the SCR is connected to an AC supply, at every end of the positive half cycle, the anode current naturally becomes zero (due to the alternating nature of the AC Supply). As the current in the circuit goes through the natural zero, a reverse voltage is applied immediately across the SCR (due to the negative half cycle). These conditions turn OFF the SCR.

This method of commutation is also called as Source Commutation or AC Line Commutation or Class F Commutation. This commutation is possible with line commutated inverters, controlled rectifiers, cyclo converters and AC voltage regulators because the supply is the AC source in all these converters.

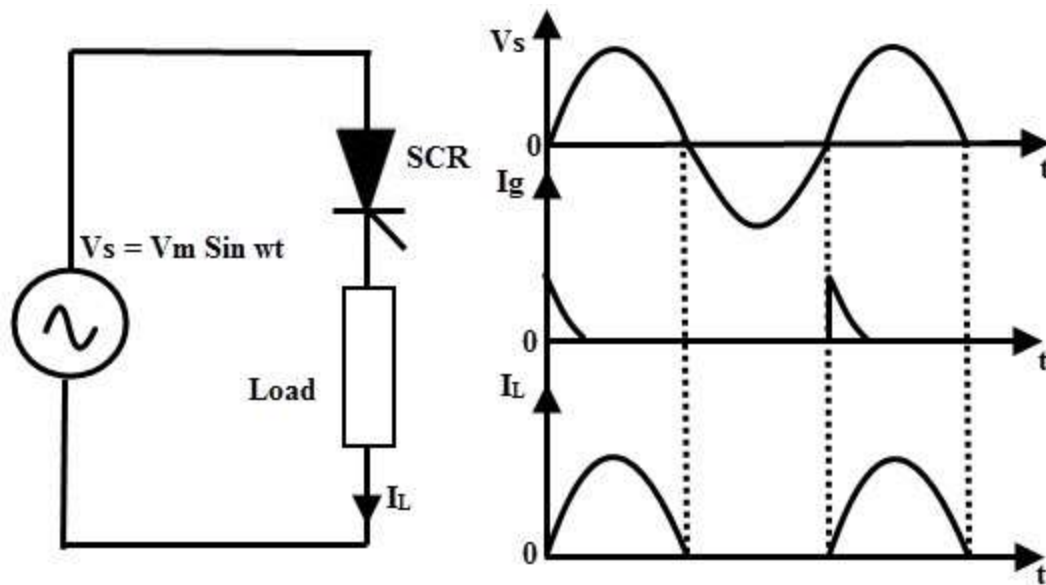

During the positive half cycle of the AC Supply, the load current flows normally. But, during the negative cycle, the SCR will turn OFF (due to momentary zero current and immediate negative polarity). For successful natural commutation, the turn OFF time t_{OFF} must be less than the duration of half cycle of the supply.

Forced Commutation

In case of DC circuits, there is no natural current zero to turn OFF the SCR. In such circuits, forward current must be forced to zero with an external circuit (known as Commutating Circuit) to commutate the SCR. Hence the name, Forced Commutation.

This commutating circuit consist of components like inductors and capacitors and they are called Commutating Components. These commutating components cause to apply a reverse voltage across the SCR that immediately bring the current in the SCR to zero.

Depending on the process for achieving zero current in the SCR and the arrangement of the commutating components, Forced Commutation is classified into different types. They are:

- Class A – Self Commutation by Resonating the Load
- Class B – Self Commutation by Resonating the Load
- Class C – Complementary Commutation

- Class D – Auxiliary Commutation
- Class E – Pulse Commutation

such as class A, B, C, D, and E. This commutation is mainly used in chopper and inverter circuits.

Class A Commutation

This is also known as Self Commutation by Resonating the Load or simply the Resonant Commutation. In this commutation, the source of commutation voltage is in the load. The commutating components are L and C and the Capacitor can be connected either in parallel or in series with the load resistance R_L as shown below.

There are also waveforms of SCR current, voltage and capacitor voltage.

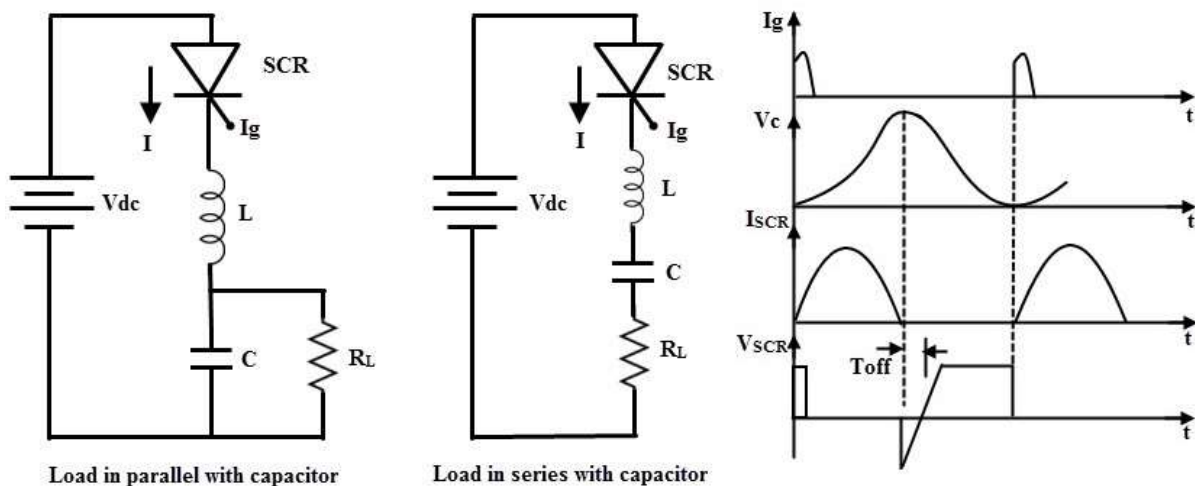

The value of load resistance and the commutating components are selected in such a way that they form an under-damped RLC resonant circuit. When the circuit is applied with a DC Source, the forward currents starts flowing through the SCR and during this period, the capacitor is charged up to the value of V_{dc} . The current in the circuit will be either of the two waveforms shown below, depending on how the load is connected to the capacitor (parallel or series).

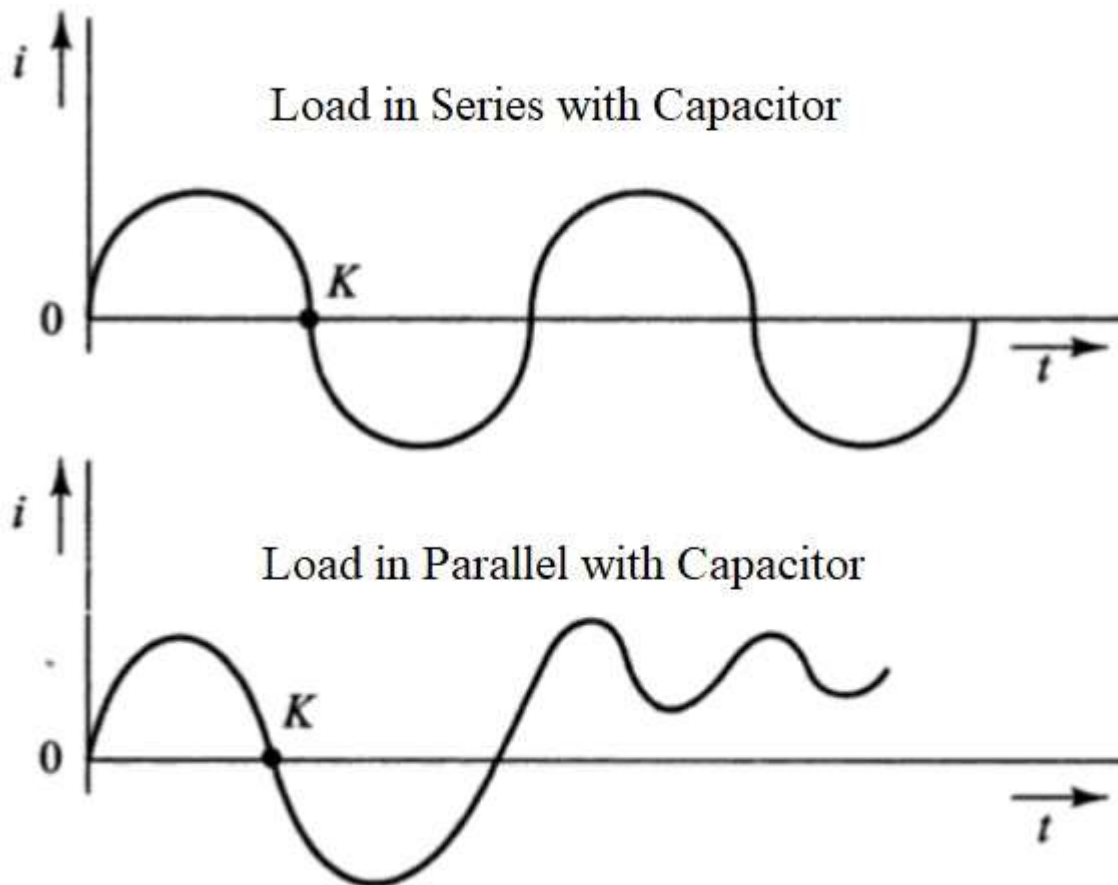

When conducting, the current in the SCR is the charging current of the capacitor. From the waveforms, it is clear that the current becomes zero at the point 'K'. At this point, the SCR turns OFF.

The resonant frequency of the circuit, which depends on the Commutation Components L and C and also on the load resistance, determines the time for switching OFF the SCR.

Class A Commutation method is simple and reliable and is usually used in high frequency operations i.e., frequencies in the range of 1000 Hz and above due to the high values of L and C components (as they carry the full load current). This type of commutation is generally used in Series Inverters.

Class-B or Resonant Pulse Commutation of SCR

Class-B or Resonant Pulse Commutation is a forced commutation technique to turn off an SCR. In this technique, thyristor or SCR is turned off by gradual build-up of resonant current in the reverse direction i.e. from cathode to anode of SCR. This technique is also known as current commutation and occurs

in DC circuit not in AC circuit. Let us consider the circuit diagram for Class-B or Resonant Pulse Commutation for better understanding of the commutation process involved.

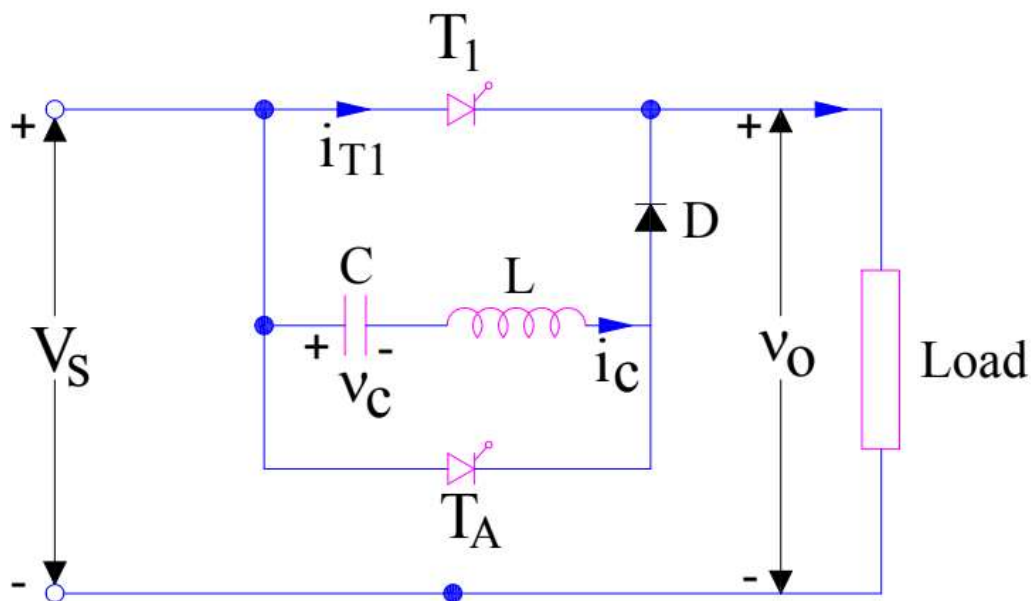

The commutation circuit comprises of Capacitor C , Inductor L and an auxiliary thyristor T_A . Initially thyristor T_1 and T_A are in off state and capacitor C is charged to voltage V_s with left hand plate positive as shown in figure. Positive direction of capacitor voltage and capacitor current i_c are shown in figure and taken as reference.

Now, at $t=0$, the main thyristor / SCR is gated and turned on. Load current equal to I_0 starts flowing through the main thyristor T_1 and Load. Now, we want to turn this thyristor off. To do this, we fire the auxiliary thyristor T_A at $t=t_1$. Till time $t=t_1$, the capacitor is charged with source voltage V_s i.e. $v_c = V_s$, capacitor current $i_c = 0$ and current through main thyristor T_1 i.e. $i_0 = I_0$. This is shown in figure below.

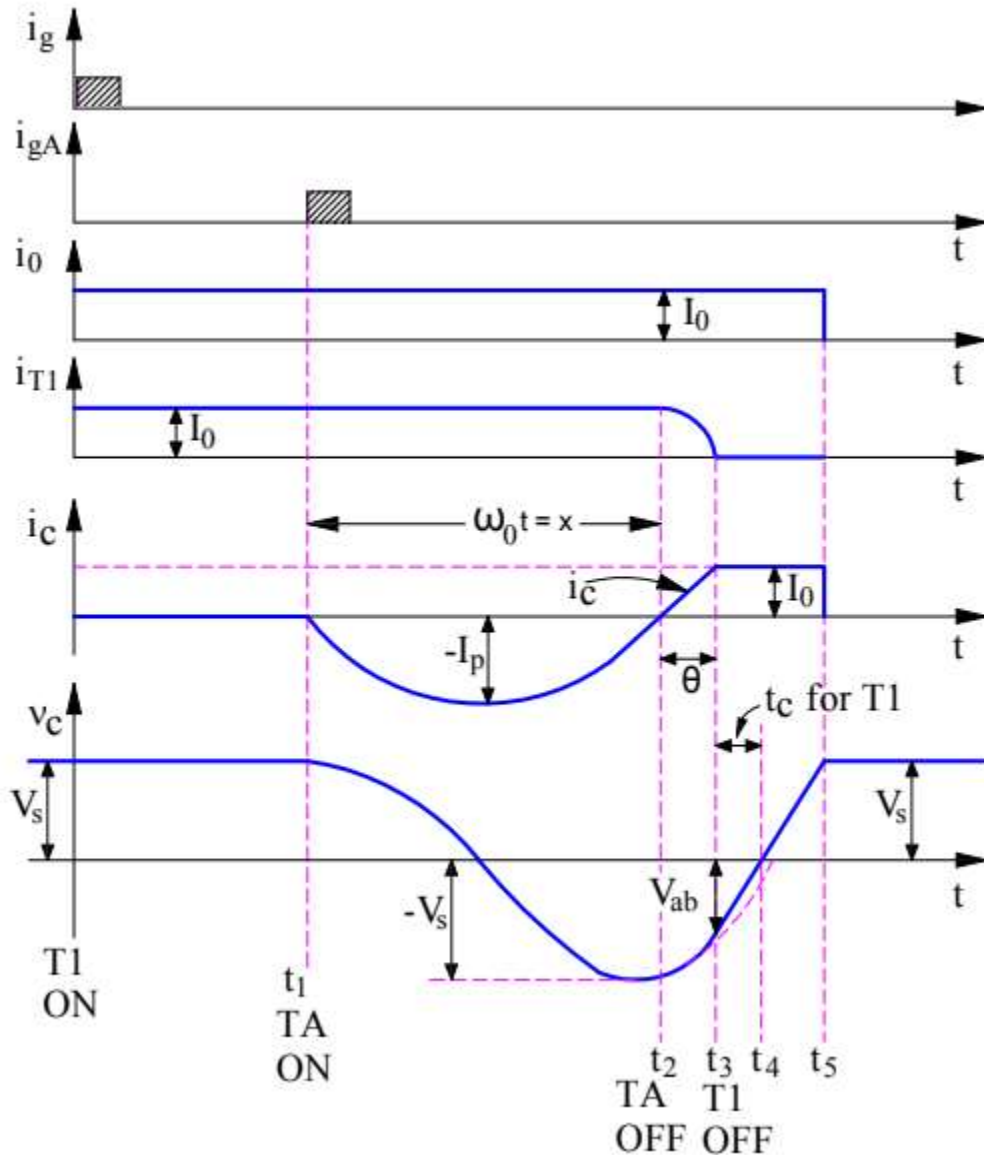

When auxiliary thyristor TA is fired, it starts conducting and provides a path for the discharge of capacitor C. L, C and TA forms a resonating circuit. The resonating current i_c for this circuit is given as

$$i_c = -V_s \sqrt{\frac{C}{L}} \sin \omega t$$

$$i_c = -I_m \sin \omega t$$

Negative sign in the above expression of resonating current is given as the actual current flows in a direction opposite to the direction of current i_c shown in the first figure.

Carefully observe the waveform of i_c . It can be seen that, after half cycle, the value of i_c reduces to zero at $t=t_2$. This means, the current through the auxiliary thyristor TA reduces to zero. Let's check if the auxiliary thyristor gets reversed biased after $t=t_2$. **Why are we checking this?** This is because, the current through TA is zero at $t=t_2$ and if it gets reversed biased after $t=t_2$ then TA will get turned off. The voltage across TA equals the voltage across capacitor. The expression for capacitor voltage can be calculated as

$$v_c = (1/C) \int i_c dt$$

$$= V_s \cos \omega t$$

Where $\omega = \text{Resonant Frequency}$

$$= 1/\sqrt{LC}$$

From the above expression of voltage across capacitor, if we put $\omega t = \pi$ then value of $\cos \omega t$ will -1. This means, the capacitor voltage will get reversed after half a cycle of capacitor current i.e. at $t=t_2$.

Thus, the auxiliary thyristor TA is reversed biased after $t=t_2$. Hence it will get turned off at $t=t_2$.

Now, TA is OFF and capacitor C is charged up to source voltage V_s with its right hand plate positive. This means, the diode D is now forward biased and hence resonating current i_c will now flow through least resistive path i.e. through C, L, D and main thyristor T_1 . But this resonating current i_c will flow through the main SCR T_1 from cathode to anode i.e. in reverse direction. This simply means, the current I through the main thyristor T_1 will be given as

$$I = I_0 - i_c$$

When the magnitude of i_c reaches I_0 , the current through the SCR T_1 will become zero. This can be seen at $t=t_3$. Now, you might ask, when the resonating current will attain a value of I_0 ? This can easily be calculated from the equation of the resonating current. Let's find it.

$$V_s \sqrt{\left(\frac{C}{L}\right)} \sin \omega(t_3 - t_2) = I_0$$

$$\sin \omega(t_3 - t_2) = \left(\frac{I_0}{I_m}\right)$$

$$\omega(t_3 - t_2) = \sin^{-1}\left(\frac{I_0}{I_m}\right)$$

$$\text{Where } \omega = \frac{1}{\sqrt{LC}} \text{ and } I_m = V_s \sqrt{\left(\frac{C}{L}\right)}$$

Now, at $t=t_3$, the current through the main thyristor T_1 is zero. Let's check, if it is reversed biased at this instant of time. Again, the voltage across the main SCR T_1 at this instant of time ($t=t_3$) is equal to the capacitor voltage. The capacitor voltage after $\omega t = \pi$ is negative. This means, the right hand plate is positive whereas left hand plate is negative. Hence, the main thyristor T_1 is reversed biased. Thus, main thyristor T_1 will turn off at $t=t_3$ as the current through it is zero and it is reversed biased after this instant of time.

From the above discussion, it should have been clear that the peak value of resonating current i_c i.e. I_m in the expression of i_c , must be more than load current (I_0) for reliable commutation of thyristor / SCR. As SCR is commutated by the gradual build-up of the resonating current i_c in the reverse direction of SCR, this method of commutation is called the **current commutation, resonant pulse commutation or Class-B commutation**.

Let's now check what happens after the commutation of main SCR T_1 . Once the main SCR T_1 is turned off, load current I_0 begins to flow from source V_s to load through C, L and D. This causes capacitor C to charge linearly from V_{ab} to zero at $t = t_4$ and then to source voltage V_s at $t=t_5$. At $t=t_5$, the capacitor is charged up to source voltage V_s with its left hand plate positive. Therefore, capacitor will not allow the flow of load current after $t = t_5$.

The circuit turn off time is equal to the time period for which the main thyristor / SCR is reversed biased. Here, this time period is $(t_4 - t_3)$. Therefore, **Circuit Turn Off time t_c for Class-A commutation = $(t_4 - t_3) = (V_{ab}C) / I_0$**

1.8SCR- PROTECTION:

Protection of a device is an important aspect for its reliable and efficient operation. SCR is a very delicate semiconductor device. So we have to use it in its specified ratings to get desired output. SCR may face different types of threats during its operation due to over voltages, over currents etc. There are different types of **thyristor protection** schemes available for satisfactory operation of the device like

1. Over voltage protection.
2. Over current protection.
3. High dv/dt protection.
4. High di/dt protection.
5. Thermal protection.

Over Voltage Protection

It is the most important protection scheme w. r. t. others as thyristors are very sensitive to over voltages. Maximum time thyristor failures happen due to over-voltage transients. A thyristor may be subjected to internal or external over-voltages.

Internal Over-Voltages : After commutation of a thyristor reverse recovery current decays abruptly with high di/dt which causes a high reverse voltage [as, $V = L(di/dt)$ so if di/dt is high then V will be large] that can exceed the rated break-over voltage and the device may be damaged.

External Over-Voltages : These are caused due to various reasons in the supply line like lightning, surge conditions (abnormal voltage spike) etc. External over voltage may cause different types of problem in thyristor operation like increase in leakage current, permanent breakdown of junctions, unwanted turn-on of devices etc. So, we have to suppress the over-voltages.

Protective Measure : The effect of over-voltages can be minimized by using non-linear resistors called voltage clamping devices like metal oxide like metal oxide varistor. At the time of normal operation it offers high impedance and acts as it is not present in the circuit. But when the voltage exceeds the rated voltage then it serves as a low impedance path to protect SCR.

Over Current Protection

Over current mainly occurs due to different types of faults in the circuit. Due to over current i^2R loss will increase and high generation of heat may take place that can exceed the permissible limit and burn the device.

Protective Measure : SCR can be protected from over current by using CB and fast acting current limiting fuses (FACL). CB are used for protection of thyristor against continuous overloads or against surge currents of long duration as a CB has long tripping time. But fast-acting fuses is used for protecting SCR against high surge current of very short duration.

High dv/dt Protection

When a thyristor is in forward blocking state then only J_2 junction is reverse biased which acts as a capacitor having constant capacitance value C_j (junction capacitance). As we know that current through capacitor follows the

relation $i = C \frac{dv}{dt} \Rightarrow i \propto \frac{dv}{dt}$ (if C constant) Hence leakage current through the

J_2 junction which is nothing but the leakage current through the device will increase with the increase in dv_a/dt i.e. rate of change of applied voltage across the thyristor. This current can turn-on the device even when the gate signal is absent. This is called dv/dt triggering and must be avoided which can be achieved by using Snubber circuit in parallel with the device.

Protective Measure : **Snubber Circuit** : It consists of a capacitor connected in series with a resistor which is applied parallel with the thyristor, when S is closed then voltage V_s is applied across the device as well as C_s suddenly. At first Snubber circuit behaves like a short circuit. Therefore voltage across the device is zero. Gradually voltage across C_s builds up at a slow rate. So dv/dt across the thyristor will stay in allowable range. Before turning on of thyristor C_s is fully charged and after turning on of thyristor it discharges through the SCR. This discharging current can be limited with the help of a resistance (R_s) connected in series with the capacitor (C_s) to keep the value of current and rate of change of current in a safe limit.

High di/dt Protection

When a thyristor is turned on by gate pulse then charge carriers spread through its junction rapidly. But if rate of rise of anode current, i.e. di/dt is greater than the spreading of charge carriers then localized heat generation will take place which is known as local hot spots. This may damage the thyristor.

Protective Measure : To avoid local hot spots we use an inductor in series with the device as it prevents high rate of change of current through it.

High Temperature Protection:

With the increase in the temperature of the junction, insulation may get failed. So we have to take proper measures to limit the temperature rise.

Protective Measure : We can achieve this by mounting the thyristor on heat sink which is mainly made by high thermal conductivity metals like aluminium (Al), Copper (Cu) etc. Mainly aluminium (Al) is used due to its low cost. There are several types of mounting techniques for SCR such as – Lead-mounting, stud-mounting, Bolt-down mounting, press-fit mounting, press-pack mounting etc.

Gate Protection of Thyristor

Like thyristor, Gate circuit should also be protected from over voltages and over currents. Over voltages in the gate circuit can cause false triggering and over current can cause high junction temperature.

Protective Measure : Over voltages **thyristor protection** is achieved by using a zener diode and a resistor can be used to protect the gate circuit from over current. Noise in gate circuit can also cause false triggering which can be avoided by using a resistor and a capacitor in parallel. A diode (D) may be connected in series or in parallel with the gate to protect it from high reverse voltage.

Overall Protection of a Thyristor

Lead mounting : In such mounting technique housing of SCR itself is used as heat radiator. Hence no need of additional heat sink arrangement. Hence, this technique of **thyristor Protection** is generally used for low current application, normally less than one ampere.

Stud mounting : The anode of the thyristor is in the form of threaded stud which is screwed to a metallic heat sink block.

Bolt-down mounting : Here the device is connected to the heat sink with the help of nut-bolt mechanism. It is mainly used in small and medium rating circuit.

Press fit mounting : This kind of mounting is obtained by inserting the whole SCR into the metallic block. It is used in high rating circuit.

Press-Pack mounting : This kind of mounting for thyristor protection is obtained by sandwiching the thyristor between to heat sink with the help of clamps. It is used for very high rating circuit.

1.9 Firing circuits

Different Triggering Circuits

1. Resistance (R) Triggering Circuit
2. Resistance-Capacitance (RC) Triggering Circuit
3. UJT Based Triggering Circuit
4. IC Based Triggering Circuit

Many of these circuits are not sophisticated and not used practically but they provide a basic understanding of the SCR triggering

Main features of firing circuits

- Gate control circuit is also called firing or triggering circuit
- Gate circuits are usually low power electronics circuits

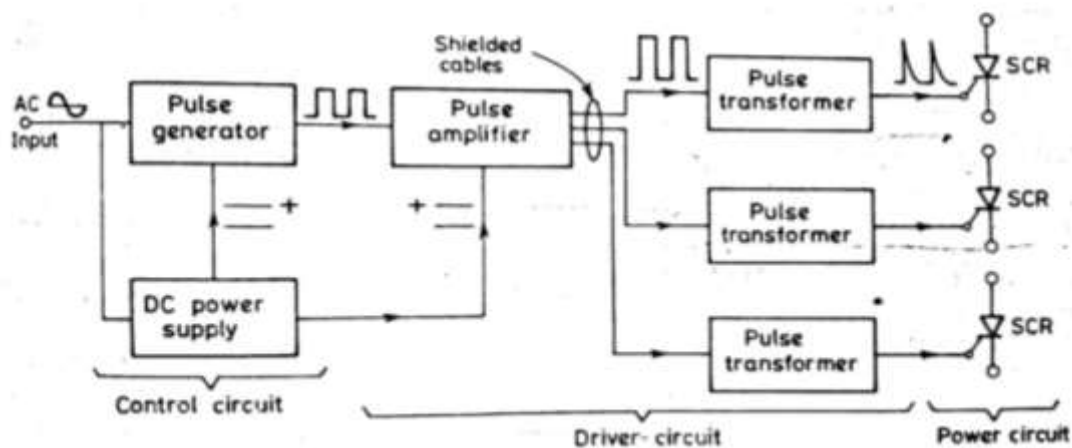

Main features of firing circuits

A firing circuit should fulfill the following two functions
• If power circuit has more than one SCR, the firing circuit should produce gating pulses for each SCR at the desired instant for proper operation of the power circuit
• The control signal generated by a firing circuit may not be able to turn on an SCR. It is therefore common to feed the voltage pulse to a driver circuit and then to a gate cathode circuit

R - Triggering Circuit

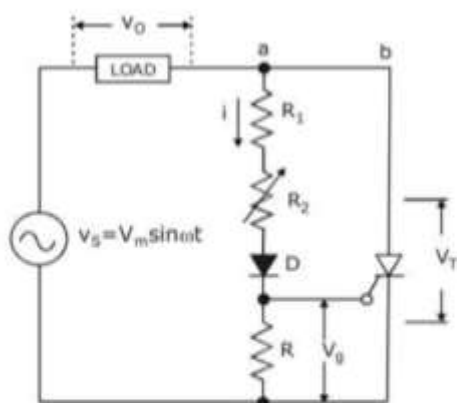

- R_1 is the gate current limiting resistance
- R_2 is used to vary the gate current and hence firing angle

$$I_{g \max} = \frac{V_m}{R_1} \quad \Rightarrow \quad R_1 \geq \frac{V_m}{I_{g \max}}$$

- R limits the voltage at Gate terminal

$$R \leq \frac{V_{g \max} R_1}{V_m - V_{g \max}}$$

- Diode D prevents build-up of negative voltage at Gate terminal

- Simplest and most economical
- Suffer from a limited range of firing angle control (0 to 90°) □
- R_2 - variable resistance
- R – stabilizing resistance
- In case $R_2=0$, gate current may flow from source, through load, R_1 , D and gate to cathode
- This current should not exceed maximum permissible gate current I_{gm}
- R_1 therefore found from the relation

$$\frac{V_m}{R_1} \leq I_{gm} \quad \text{or} \quad R_1 \geq \frac{V_m}{I_{gm}}$$

- Function of R_1 is to limit the gate current to a safe value as R_2 is varied

- Resistance R should have a value such that maximum voltage drop across it does not exceed maximum possible gate voltage V_{gm}
- This can happen only when R_2 is zero, Under this condition, $V_m \cdot R / (R_1 + R) \leq V_{gm}$ As resistance R_1, R_2 are large, gate trigger circuit draws a small current, Diode D allows the flow of current during positive half cycle only, The amplitude of this dc pulse can be controlled by varying R_2
- The potentiometer setting R_2 determines the gate voltage amplitude, When R_2 is large current i is small and the voltage across R, $v_g = i \cdot R$ is also small, As V_{gp} is less than V_{gt} , SCR will not turn on, Therefore load voltage $v_o = 0$, $i_o = 0$ and supply voltage appear across SCR, Trigger circuit consist of resistance only, therefore v_g is in phase with source voltage v_s , R_2 is adjusted such that $V_{gp} = V_{gt}$, this gives the value of firing angle as 90°

R triggering circuit (Resistance triggering)

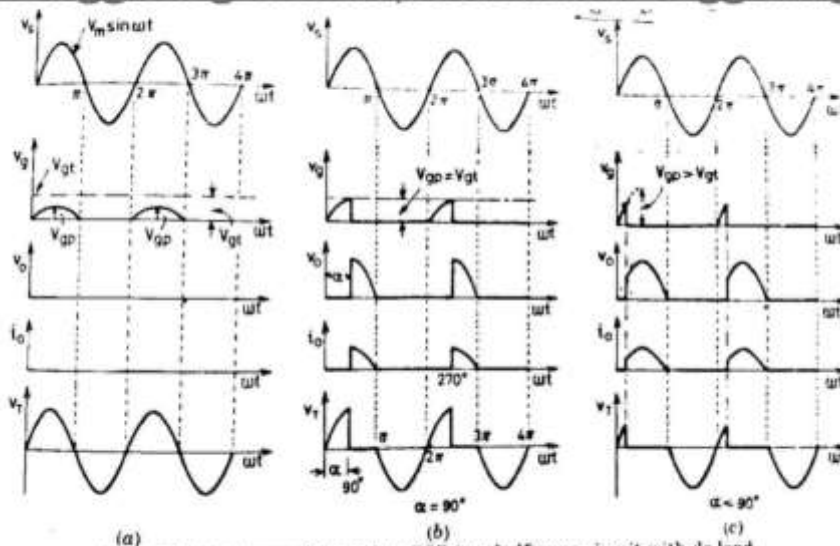

Fig. 4.65. Resistance firing of an SCR in a half-wave circuit with dc load
(a) No triggering of SCR (b) $\alpha = 90^\circ$ (c) $\alpha < 90^\circ$.

- The same circuit also is applicable for TRIAC. However, diode D_1 has to be removed such that a trigger signal will be available at the gate terminal during both halfcycles. Because the gate of a TRIAC is not equally sensitive in all four of its modes of switching, α and hence v_o are usually different in the positive and negative half-cycles of the supply voltage.

Features of R-Trig Circuit

❑ Simple circuit

❑ Disadvantages:

- Performance depends on temperature and SCR characteristics
- Minimum phase angle is typically 2-4 degrees only (not zero degree)
- Maximum phase angle is only 90 degrees

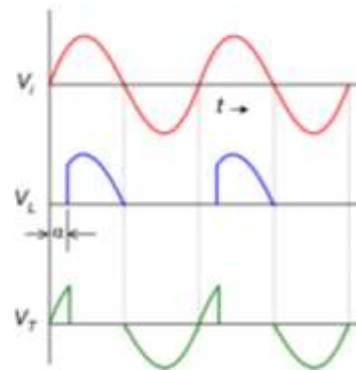
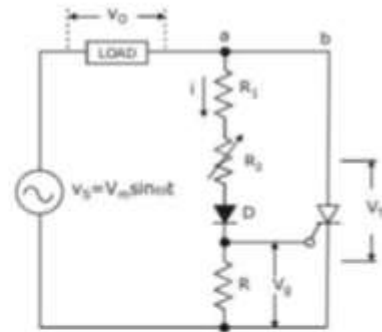

RC triggering circuit

The limited range of firing angle control by resistance firing circuit can be overcome by RC firing circuit. Several variations of RC trigger circuits are available. In these cases the range of α is extendable beyond 90. RC half wave triggering circuit. By varying the value R, firing angle can be controlled from 0 to 180. In the -ve half cycle capacitor C charges through D_2 with lower plate +ve to the peak supply voltage V_m at $\omega t = -90$. After $\omega t = -90$, source voltage V_s decreasing from $-V_m$ at $\omega t = -90$ to zero at $\omega t = 0$.

RC Triggering Circuit

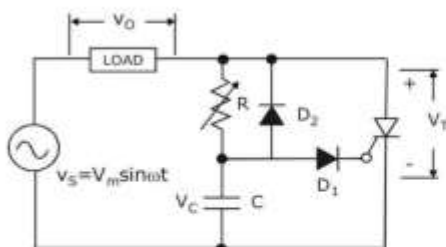

- ❑ Capacitor charges during the negative half cycle through D_2
- ❑ When SCR is turned on, capacitor C is suddenly discharged through D_2
- ❑ D_1 protects the SCR during negative half cycle

Advantage over R-triggering Circuit:

Controls upto 180 degrees

$$RC \geq \frac{1.3T}{2}$$

To ensure minimum gate current

$$v_s \geq R I_{g \min} + V_{g \min} + V_{D_1}$$

$$R \leq \frac{v_s - V_{g \min} - V_{D_1}}{I_{g \min}}$$

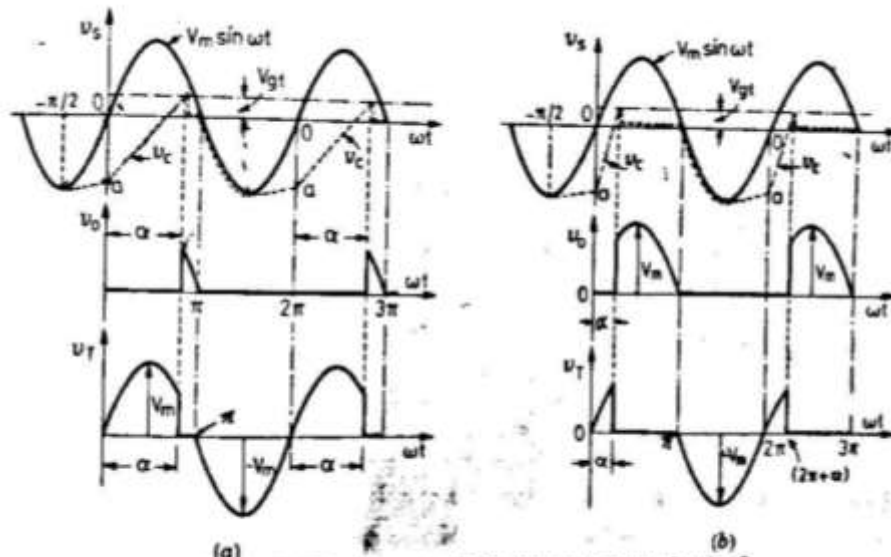

Fig. 4.67. Waveforms for RC half-wave trigger circuit of Fig. 4.66 (a) high value of R (b) low value of R.

During this period capacitor voltage may fall from $-V_m$ to some small value $-o_a$, Now the charging of the capacitor (with upper plate positive) takes place through R and the charging rate depends on the time-period RC. When capacitor charges to +ve voltage equal to V_{GT} , conduction of the SCR takes place. After this capacitor holds a small +ve voltage, Diode D1 used to prevent the breakdown of cathode to gate junction through D2 during the $-ve$ cycle

$$RC \geq 0.65T = 4/\omega$$

- where the angular frequency of ac mains $\omega t = 2\pi/T$.

$$RC \geq \frac{1.3 T}{2} = \frac{4}{\omega}$$

- The value of R is chosen such that the required I_{GT} and V_{GT} are supplied to the gate terminal:

$$R \leq \frac{V_s - V_{gt} - v_d}{I_{gt}}$$

- Where v is the voltage at the switching instant of thyristor and v_D is forward voltage drop of diode D1

RC Trig Waveforms

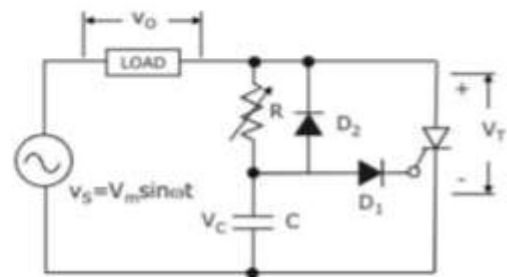
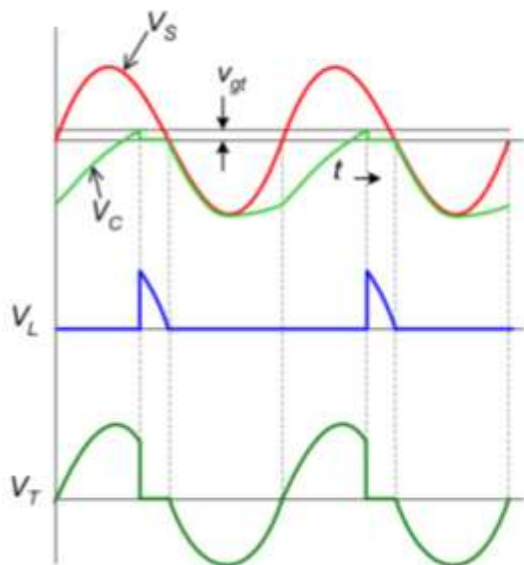

$$RC \geq \frac{1.3T}{2}$$

RC Full wave trigger circuit

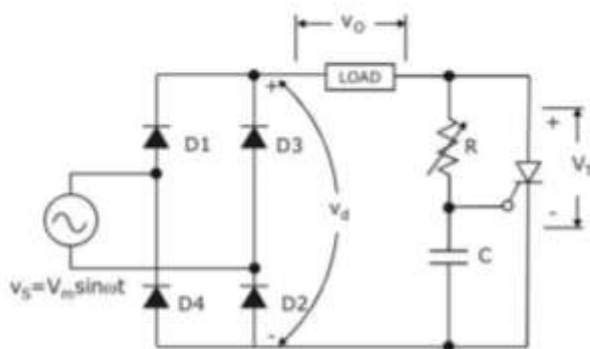

- Initial Capacitor voltage in each half cycle is almost zero

$$RC \geq \frac{50T}{2}$$

$$R \leq \frac{v_s - V_{g \min}}{I_{g \min}}$$

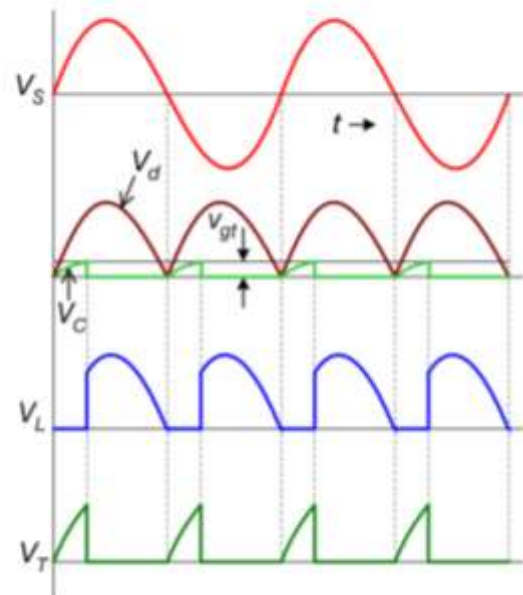

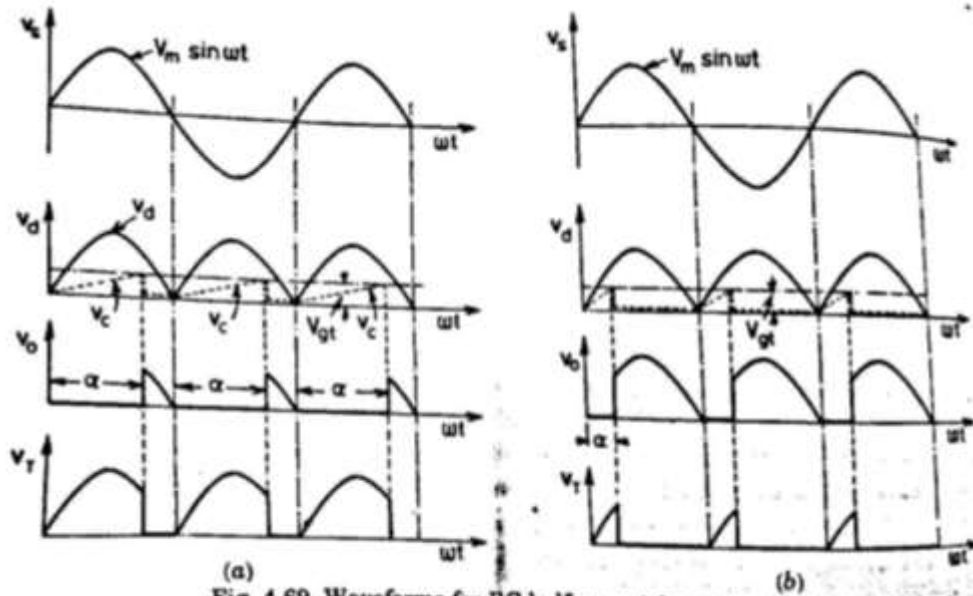

Fig. 4.69. Waveforms for RC half-wave trigger circuit of Fig. 4.68 (a) high value of R (b) low value of R.

Diode D1-D4 form a full – wave diode bridge □ When capacitor charges to a voltage equal to Vgt, SCR triggers and rectified voltage Vd appears across load as Vo □ The value of RC can be calculated by

$$RC \geq 50T/2 = 157/\omega$$

R is given by $R \ll (Vs - Vgt)/Igt$

Unijunction Transistor (UJT)

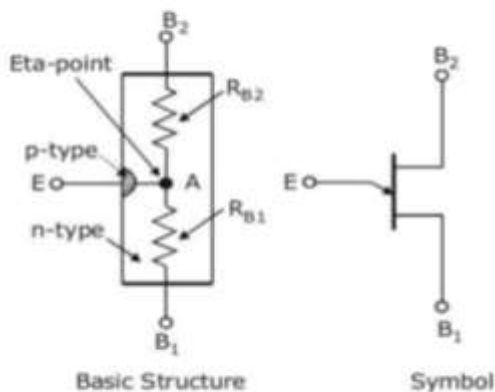

- Has a lightly doped n-type silicon layer to which a heavily doped p-type emitter is embedded
- The inter-base resistance is in the range of 5 – 10 kΩ
- This device cannot 'amplify'

UJT Equivalent Circuit

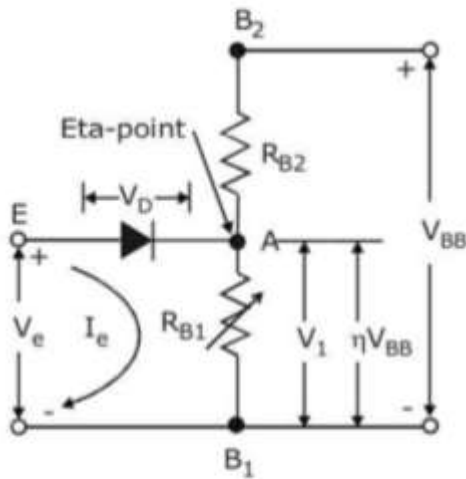

$$V_{AB_1} = \frac{R_{B_1}}{R_{B_1} + R_{B_2}} V_{BB} = \eta V_{BB}$$

η is called **intrinsic standoff ratio**

Value of η varies from 0.5 – 0.8

- When V_c is more than $V_1 + V_D$, then the diode is forward biased and a current flows through R_{B_1}
- Number of carriers in R_{B_1} increases and the resistance reduces
- V_c decreases with increase in I_c and therefore the device is said to exhibit negative resistance

UJT Characteristics

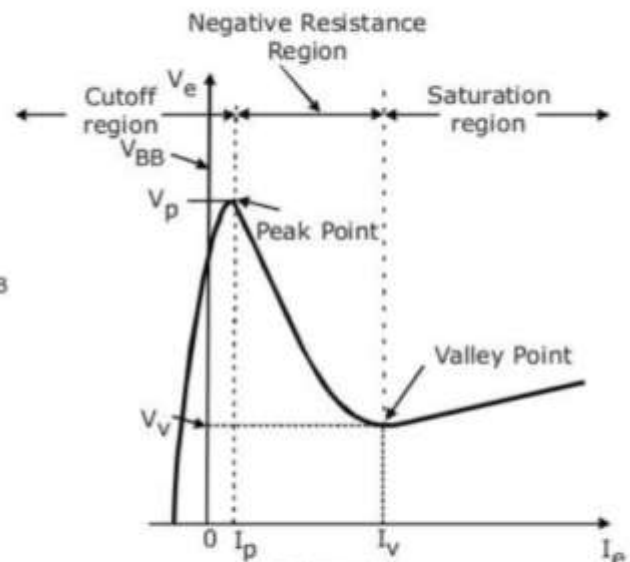
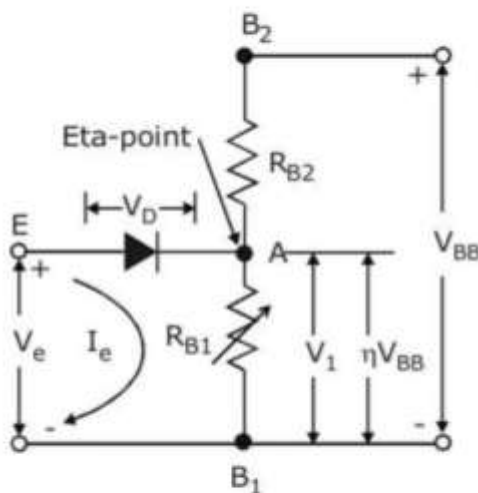

At peak point, $V_c = V_1 + V_D$.

At Valley point, R_{B_1} is minimum

1.10 DESIGN OF SNUBBER CIRCUITS

If the rate of rise of forward voltage dV_a/dt is high, the charging current i will be more. This charging current plays the role of gate current and turns on the SCR even when gate signal is zero. Such phenomena of turning-on a thyristor, called dv/dt turn-on must be avoided as it leads to false operation of the thyristor circuit. For controllable operation of the thyristor, the rate of rise of forward anode to cathode voltage dV_a/dt must be kept below the specified rated limit. Typical values of dv/dt are 20 – 500 V/ μ sec. False turn-on of a thyristor by large dv/dt can be prevented by using a snubber circuit in parallel with the device.

4.7.1. Design of Snubber Circuits

A snubber circuit consists of a series combination of resistance R_s and capacitance C_s in parallel with the thyristor as shown in Fig. 4.25. Strictly speaking, a capacitor C_s in parallel with the device is sufficient to prevent unwanted dv/dt triggering of the SCR. When switch S is closed, a sudden voltage appears across the circuit. Capacitor C_s behaves like a short circuit,

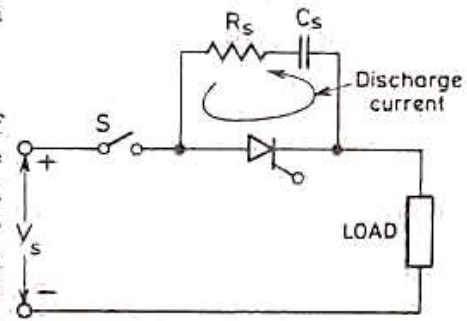

Fig. 4.25. Snubber circuit across SCR.

therefore voltage across SCR is zero. With the passage of time, voltage across C_s builds up at a slow rate such that dv/dt across C_s and therefore across SCR is less than the specified maximum dv/dt rating of the device. Here the question arises that if C_s is enough to prevent accidental turn-on of the device by dv/dt , what is the need of putting R_s in series with C_s ? The answer to this is as under.

Before SCR is fired by gate pulse, C_s charges to full voltage V_s . When the SCR is turned on, capacitor discharges through the SCR and sends a current equal to V_s/r (resistance of local path formed by C_s and SCR). As this resistance is quite low, the turn-on di/dt will tend to be excessive and as a result, SCR may be destroyed. In order to limit the magnitude of discharge current, a resistance R_s is inserted in series with C_s as shown in Fig. 4.25. Now when SCR is turned on, initial discharge current V_s/R_s is relatively small and turn-on di/dt is reduced.

In actual practice ; R_s , C_s and the load circuit parameters should be such that dv/dt across C_s during its charging is less than the specified dv/dt rating of the SCR and discharge current at the turn-on of SCR is within reasonable limits. Normally, R_s , C_s and load circuit parameters form an underdamped circuit so that dv/dt is limited to acceptable values.

The design of snubber circuit parameters is quite complex. Here only an approximate method of their calculation is presented in Example 4.13. In practice, designed snubber parameters are adjusted up or down in the final assembled power circuit so as to obtain a satisfactory performance of the power electronics system.

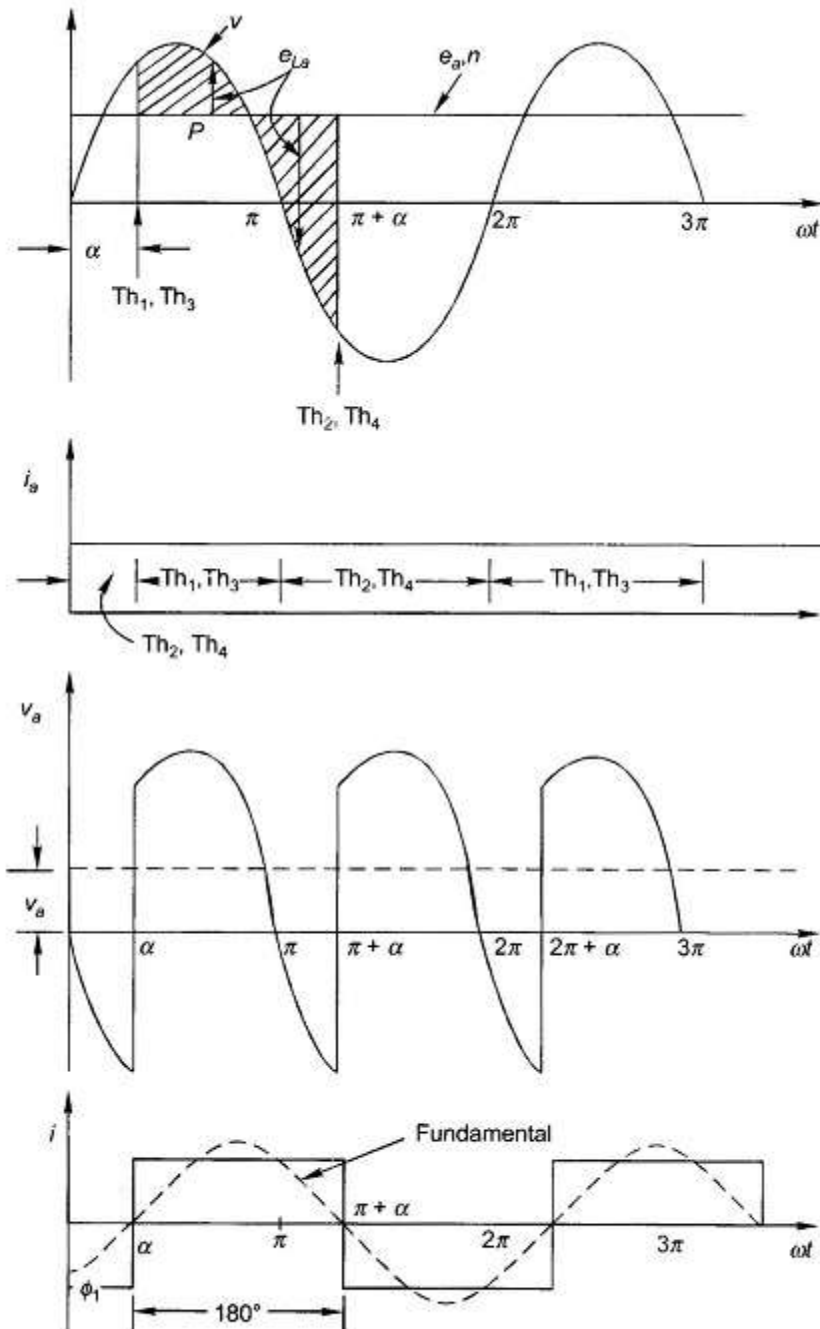

Fig 11.19 Voltage and current waveforms of full-converter feeding separately excited dc motor, continuous armature current (almost constant); $\alpha < 90^\circ$

However, during π to $\pi + \alpha$, some of the motor energy is fed back to the supply (v and i have opposite polarity and so are v_a and i_a which means reversal of power flow). Observe that the fundamental of the current drawn from the mains lags the voltage by angle $\Phi_1 = \alpha$.

The voltage and current waveforms for $\alpha > 90^\circ$ are shown in Fig. 11.20. The average motor terminal voltage is now negative. If the motor terminals are reversed, it will act as a generator feeding power back to the ac supply. This is

the **inversion operation** of the converter and is used in regenerative braking of the motor. One point needs to be noted here. During the conduction period of either Th_1Th_3 or Th_2Th_4 as the supply voltage becomes negative, the armature current begins to reduce, causing the inductance polarity to reverse so that the conducting thyristors continue to be forward-biased.

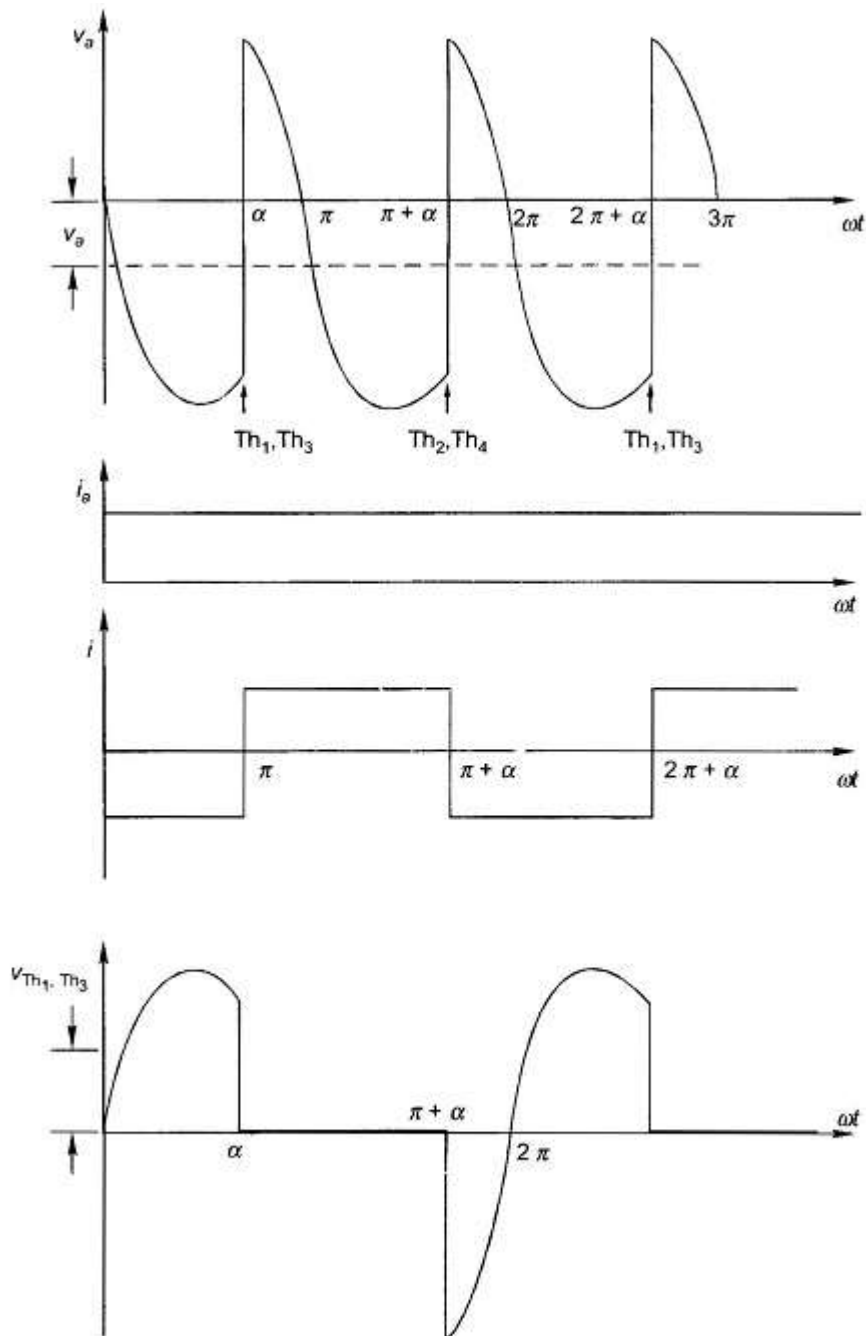

Fig. 11.20 Voltage and current waveforms for full converter; $\alpha > 90^\circ$

The voltage and current waveforms for the case of discontinuous armature current can be found as in the case of the semi-converter. (see Fig. 11.20).

Torque-Speed Characteristics:

It will be assumed here that the armature current is continuous. For a semi-converter with free-wheeling diode action, the armature circuit equations are

$$v_a = v = R_a i_a + L_a \frac{di_a}{dt} + e_a \quad \alpha < \omega t < \pi \quad (11.2)$$

$$v_a = 0 = R_a i_a + L_a \frac{di_a}{dt} + e_a \quad \pi < \omega t < \pi + \alpha \quad (11.3)$$

For a full-converter, the armature circuit equation is

$$v_a = v = R_a i_a + L_a \frac{di_a}{dt} + e_a \quad \alpha < \omega t < \pi + \alpha \quad (11.4)$$

Let $v = \sqrt{2} V \sin \omega t$. The average motor terminal voltages are: With a semi-converter,

$$V_a = \frac{1}{\pi} \int_{\alpha}^{\pi} \sqrt{2} V \sin \omega t d(\omega t) = \frac{\sqrt{2} V}{\pi} (1 + \cos \alpha) \quad (11.5)$$

With a full-converter,

$$V_a = \frac{1}{\pi} \int_{\alpha}^{\pi + \alpha} \sqrt{2} V \sin \omega t d(\omega t) = \frac{2\sqrt{2} V}{\pi} \cos \alpha \quad (11.6)$$

Figure 11.21 gives the variation of the motor terminal voltage as a function of the firing angle for both the semi-converter and full-converter. In the case of the full-converter inversion operation occurs for $90^\circ < \alpha < 180^\circ$.

MODULE-2

UNDERSTAND THE WORKING OF CONVERTERS, AC REGULATORS AND CHOPPERS

2.1 CONTROLLED RECTIFIER

Rectifier are used to convert A.C to D.C supply. Rectifiers can be classified as single phase rectifier and three phase rectifier. Single phase rectifier are classified as 1- Φ half wave and 1- Φ full wave rectifier. Three phase rectifier are classified as 3- Φ half wave rectifier and 3- Φ full wave rectifier. 1- Φ Full wave rectifier are classified as 1- Φ mid point type and 1- Φ bridge type rectifier. 1- Φ bridge type rectifier are classified as 1- Φ half controlled and 1- Φ full controlled rectifier. 3- Φ full wave rectifier are again classified as 3- Φ mid point type and 3- Φ bridge type rectifier. 3- Φ bridge type rectifier are again divided as 3- Φ half controlled rectifier and 3- Φ full controlled rectifier

2.2 Single phase half wave circuit with R load:

6.1. PRINCIPLE OF PHASE CONTROL

The simplest form of controlled rectifier circuits consist of a single thyristor feeding dc power to a resistive load R as shown in Fig. 6.1 (a). The source voltage is $v_s = V_m \sin \omega t$, Fig. 6.1 (b). An SCR can conduct only when anode voltage is positive and a gating signal is applied. As such, a thyristor blocks the flow of load current i_o until it is triggered. At some delay angle α , a positive gate signal applied between gate and cathode turns on the SCR. Immediately, full supply voltage is applied to the load as v_o , Fig. 6.1 (b). At the instant of delay angle α , v_o rises from zero to $V_m \sin \alpha$ as shown. For resistive load, current i_o is in phase with v_o . Firing angle of a thyristor is measured from the instant it would start conducting if it were replaced by a diode. In Fig. 6.1, if thyristor is replaced by diode, it would begin conduction at $\omega t = 0, 2\pi, 4\pi$ etc.; firing angle is therefore measured from these instants. A *firing angle* may thus be defined as the angle between the instant thyristor would conduct if it were a diode and the instant it is triggered.

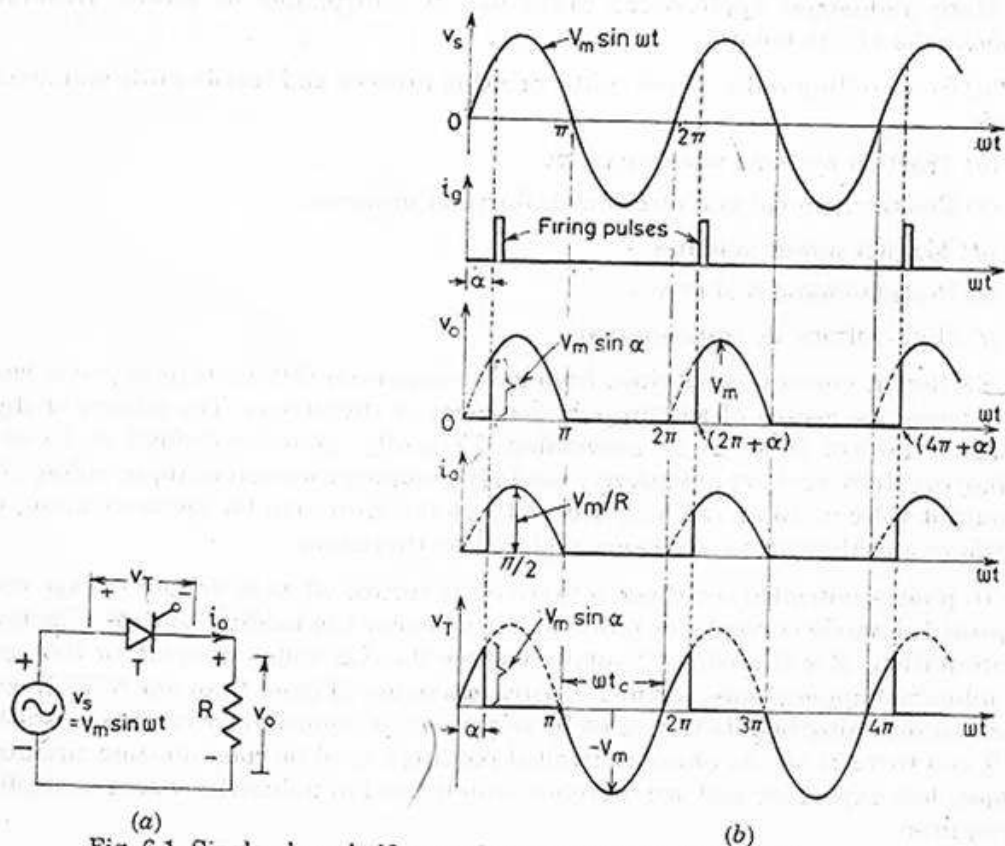

Fig. 6.1. Single-phase half-wave thyristor circuit with R load
(a) circuit diagram and (b) voltage and current waveforms.

A firing angle may also be defined as follows: A *firing angle* is measured from the angle that gives the largest average output voltage, or the highest load voltage. If thyristor in Fig. 6.1 is fired at $\omega t = 0, 2\pi, 4\pi$ etc., the average load voltage is the highest; the firing angle should thus be measured from these instants. A *firing angle* may thus be defined as the angle measured from the instant that gives the largest average output voltage to the instant it is triggered.

Once the SCR is on, load current flows, until it is turned-off by reversal of voltage at $\omega t = \pi, 3\pi$ etc. At these angles of $\pi, 3\pi, 5\pi$ etc. load current falls to zero and soon after the supply voltage reverse biases the SCR, the device is therefore turned off. It is seen from Fig. 6.1 (b) that by varying the firing angle α , the phase relationship between the start of the load current and the supply voltage can be controlled; hence the term *phase control* is used for such a method of controlling the load currents [3].

A single-phase half-wave circuit is one which produces only one pulse of load current during one cycle of source voltage. As the circuit shown in Fig. 6.1 (a) produces only one load current pulse for one cycle of sinusoidal source voltage, this circuit represents a single-phase half-wave thyristor circuit.

In Fig. 6.1 (b), thyristor conducts from $\omega t = \alpha$ to $\pi, (2\pi + \alpha)$ to 3π and so on. Over the firing angle delay α , load voltage $v_0 = 0$ but during conduction angle $(\pi - \alpha)$, $v_0 = v_s$. As firing angle is increased from zero to π , the average load voltage decreases from the largest value to zero.

The variation of voltage across thyristor is also shown as v_T in Fig. 6.1 (b). Thyristor remains on from $\omega t = \alpha$ to $\pi, (2\pi + \alpha)$ to 3π etc., during these intervals $v_T = 0$ (strictly speaking 1 to 1.5 V). It is off from π to $(2\pi + \alpha)$, 3π to $(4\pi + \alpha)$ etc., during these off intervals v_T has the waveshape of supply voltage v_s . It may be observed that $v_s = v_0 + v_T$. As the thyristor is reverse biased for π radians, the circuit turn-off time is given by

$$t_c = \frac{\pi}{\omega} \text{ sec}$$

where $\omega = 2\pi f$ and f is the supply frequency in Hz.

The circuit turn-off time t_c must be than the SCR turn-off time t_q as specified by the manufacturers.

Average voltage V_0 across load R in Fig. 6.1 for the single-phase half-wave circuit in terms of firing angle α is given by

$$V_0 = \frac{1}{2\pi} \int_{\alpha}^{\pi} V_m \sin \omega t \cdot d(\omega t) = \frac{V_m}{2\pi} (1 + \cos \alpha) \quad \dots(6.1)$$

The maximum value of V_0 occurs at $\alpha = 0^\circ$.

$$\therefore V_{o-m} = \frac{V_m}{2\pi} \cdot 2 = \frac{V_m}{\pi}$$

$$\text{Average load current, } I_0 = \frac{V_0}{R} = \frac{V_m}{2\pi R} (1 + \cos \alpha) \quad \dots(6.2)$$

Single phase half wave circuit with R-L load

A single-phase half-wave thyristor circuit with RL load is shown in Fig. 6.2 (a). Line voltage v_s is sketched in the top of Fig. 6.2 (b). At $\omega t = \alpha$, thyristor is turned on by gating signal. The load voltage v_o at once becomes equal to source voltage v_s as shown. But the inductance L forces the load, or output, current i_o to rise gradually. After some time, i_o reaches maximum value and then begins to decrease. At $\omega t = \pi$, v_o is zero but i_o is not zero because of the load inductance L . After $\omega t = \pi$, SCR is subjected to reverse anode voltage but it will not be turned off as load current i_o is not less than the holding current. At some angle $\beta > \pi$, i_o reduces to zero and SCR is turned off as it is already reverse biased. After $\omega t = \beta$, $v_o = 0$ and $i_o = 0$. At $\omega t = 2\pi + \alpha$, SCR is triggered again, v_o is applied to the load and load

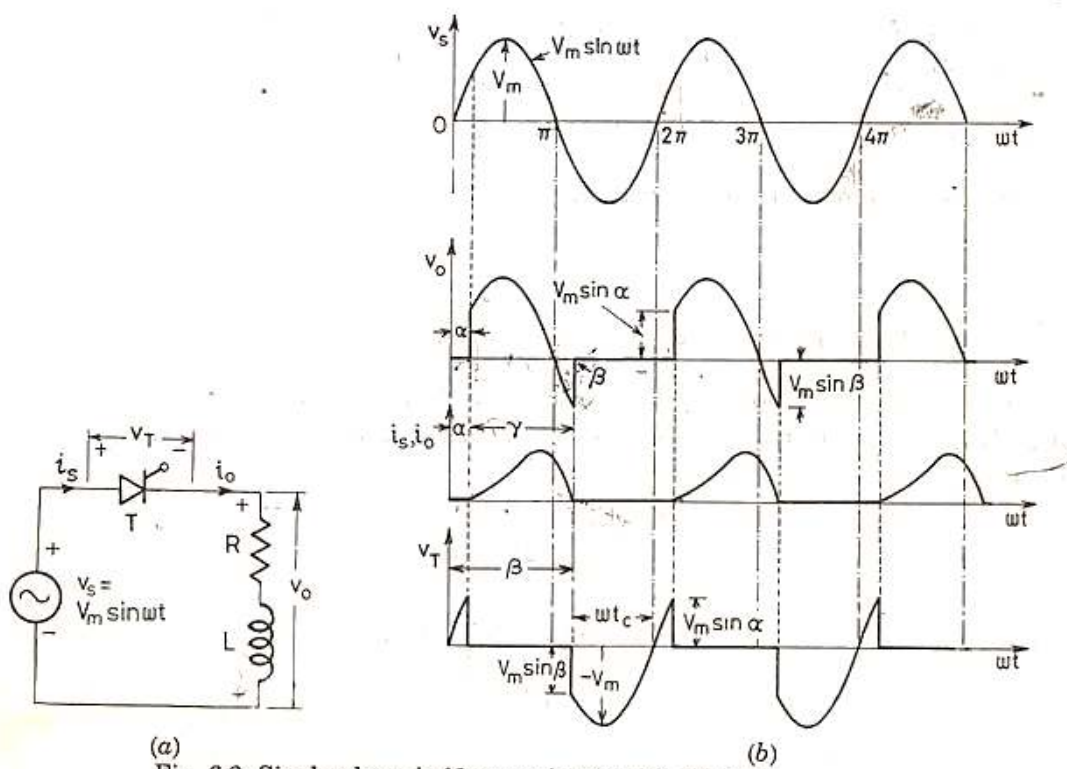

Fig. 6.2. Single-phase half-wave circuit with RL load
(a) circuit diagram and (b) voltage and current waveforms.

current develops as before. Angle β is called the *extinction angle* and $(\beta - \alpha) = \gamma$ is called the *conduction angle*.

The waveform of voltage v_T across thyristor T in Fig. 6.2 (b) reveals that when $\omega t = \alpha$, $v_T = V_m \sin \alpha$; from $\omega t = \alpha$ to β , $v_T = 0$ and at $\omega t = \beta$, $v_T = V_m \sin \beta$. As $\beta > \pi$, v_T is negative at $\omega t = \beta$. Thyristor is therefore reverse biased from $\omega t = \beta$ to 2π . Thus, circuit turn-off time $t_C = \frac{2\pi - \beta}{\omega}$ sec. For satisfactory commutation, t_C should be more than t_q the thyristor turn-off time.

The voltage equation for the circuit of Fig. 6.2 (a) is

$$V_m \sin \omega t = R i_0 + L \frac{di_0}{dt}$$

The load current i_0 consists of two components, one steady-state component i_s and the other transient component i_t . Here i_s is given by

$$i_s = \frac{V_m}{\sqrt{R^2 + X^2}} \sin (\omega t - \phi)$$

where $\phi = \tan^{-1} \frac{X}{R}$ and $X = \omega L$. Here ϕ is the angle by which rms current I_s lags V_s .

The transient component i_t can be obtained from force-free equation

$$R i_t + L \frac{di_t}{dt} = 0$$

Its solution gives,

$$i_t = A e^{-(R/L)t}$$

\therefore

$$i_0 = i_s + i_t = \frac{V_m}{Z} \sin (\omega t - \phi) + A e^{-(R/L)t} \quad \dots(6.6)$$

where

$$Z = \sqrt{R^2 + X^2}$$

$$V_0 = \frac{1}{2\pi} \int_{\alpha}^{\beta} V_m \sin \omega t \, d(\omega t) = \frac{V_m}{2\pi} (\cos \alpha - \cos \beta) \quad \dots(6.8)$$

Average load current, $I_0 = \frac{V_m}{2\pi R} (\cos \alpha - \cos \beta)$... (6.9)

Rms load voltage,
$$V_{or} = \left[\frac{1}{2\pi} \int_{\alpha}^{\beta} V_m^2 \sin^2 \omega t \cdot d(\omega t) \right]^{1/2}$$

$$= \frac{V_m}{2\sqrt{\pi}} \left[(\beta - \alpha) - \frac{1}{2} (\sin 2\beta - \sin 2\alpha) \right]^{1/2} \quad \dots(6.10)$$

Rms load current can be obtained from Eq. (6.7) if required.

6.1.2. Single-phase Half-wave Circuit with RL Load and Freewheeling Diode

The waveform of load current i_0 in Fig. 6.2 (b) can be improved by connecting a freewheeling (or flywheeling) diode across load as shown in Fig. 6.3 (a). A freewheeling diode is also called by-pass or commutating diode. At $\omega t = 0$, source voltage is becoming positive. At some delay angle α , forward biased SCR is triggered and source voltage v_s appears across load as v_o . At $\omega t = \pi$, source voltage v_s is zero and just after this instant, as v_s tends to reverse, freewheeling diode FD is forward biased through the conducting SCR. As a result, load current i_0 is immediately transferred from SCR to FD as v_s tends to reverse. At the same time, SCR

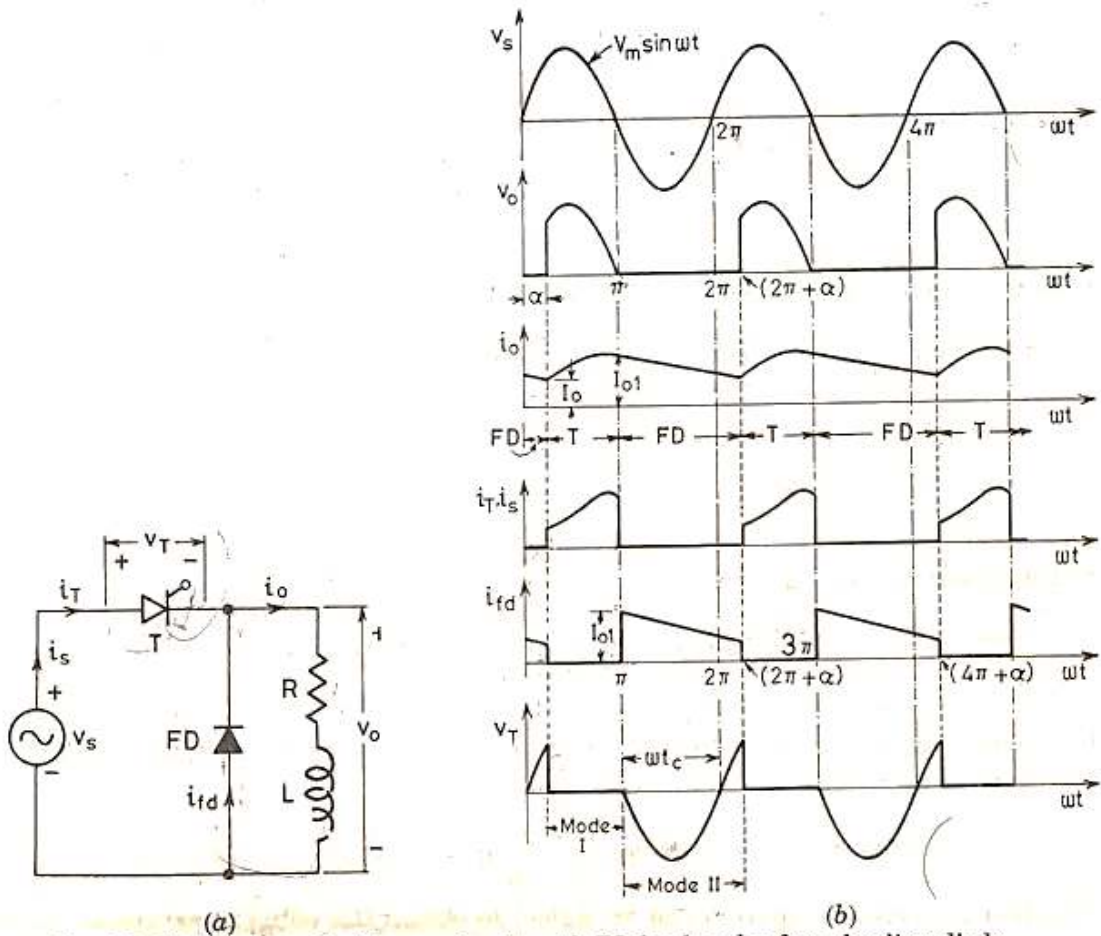

Fig. 6.3. Single-phase half-wave circuit with RL load and a freewheeling diode, (a) circuit diagram and (b) voltage and current waveforms.

is subjected to reverse voltage and zero current, it is therefore turned off at $\omega t = \pi$. It is assumed that during freewheeling period load current does not decay to zero until the SCR is triggered again at $(2\pi + \alpha)$. Voltage drop across FD is taken as almost zero, the load voltage v_0 is, therefore, zero during the freewheeling period. The voltage variation across SCR is shown as v_T in Fig. 6.3 (b). It is seen from this wave-form that SCR is reverse biased from $\omega t = \pi$ to $\omega t = 2\pi$. Therefore, circuit turn-off time is

$$t_C = \frac{\pi}{\omega} \text{ sec}$$

The source current i_s and thyristor current i_T have the same waveform as shown.

Operation of the circuit of Fig. 6.3 (a) can be explained in two modes. In the first mode, called *conduction mode*, SCR conducts from α to π , $2\pi + \alpha$ to 3π and so on and FD is reverse biased. The duration of this mode is for $[(\pi - \alpha)/\omega]$ sec. Let the load current at the beginning of mode I be I_0 . The expression for current i_0 in mode I can be obtained as follows :

Mode I : For conduction mode, the voltage equation is

$$V_m \sin \omega t = Ri_0 + L \frac{di_0}{dt}$$

Its solution, already obtained in the previous section, is repeated here from Eq. (6.6) as

$$i_0 = \frac{V_m}{Z} \sin (\omega t - \phi) + A e^{-1(R/L)t}$$

At $\omega t = \alpha$, $i_0 = I_0$, i.e. at $t = \frac{\alpha}{\omega}$, $i_0 = I_0$

Note that for mode I, $\alpha \leq \omega t \leq \pi$

Mode II : This mode, called *freewheeling mode*, extends from π to $2\pi + \alpha$, 3π to $4\pi + \alpha$ and so on. In this mode, SCR is reverse biased from π to 2π , 3π to 4π ... as shown by voltage waveform v_T in Fig 6.3 (b). As the load current is assumed continuous, FD conducts from π to $(2\pi + \alpha)$, 3π to $(4\pi + \alpha)$ and so on. Let the current at the beginning of mode II be I_{01} as shown. As load current is passing through FD, the voltage equation for mode II is

$$0 = Ri_0 + L \frac{di_0}{dt}$$

Its solution is

$$i_0 = A e^{-(R/L)t}$$

At $\omega t = \pi$,

$$i_0 = I_{01}$$

It gives

$$A = I_{01} e^{R\pi/\omega L}$$

\therefore

$$i_0 = I_{01} \cdot \exp \left[-\frac{R}{L} \left(t - \frac{\pi}{\omega} \right) \right] \quad \dots(6.12)$$

Note that for mode II,

$$\pi < \omega t \leq (2\pi + \alpha)$$

Average load voltage V_0 from Fig. 6.3 (b) is given by

$$V_0 = \frac{1}{2\pi} \int_{\alpha}^{\pi} V_m \sin \omega t d(\omega t) = \frac{V_m}{2\pi} (1 + \cos \alpha) \quad \dots(6.13)$$

2,3 Understand need of freewheeling diode

$$\text{Average load current, } \bar{I}_0 = \frac{V_0}{R} = \frac{V_m}{2\pi R} (1 + \cos \alpha) \quad \dots(6.14)$$

Note that load current i_0 is contributed by SCR from α to π , $(2\pi + \alpha)$ to 3π and so on and by FD from 0 to α , π to $(2\pi + \alpha)$ and so on. Thus the waveshape of thyristor current i_T is identical with the waveshape of i_0 for $\omega t = \alpha$ to π , $(2\pi + \alpha)$ to 3π and so on. Similarly, the wave shape of FD current i_{fd} is identical with the waveform of i_0 for $\omega t = 0^\circ$ to α , π to $(2\pi + \alpha)$ and so on.

In Fig. 6.2, load consumes power p_1 from source for α to π (both v_0 and i_0 are positive) whereas energy stored in inductance L is returned to the source as power p_2 for π to β (v_0 is negative and i_0 is positive). As a result, net power consumed by the load is the difference of these two powers p_1 and p_2 . In Fig. 6.3, load absorbs power for α to π , but for π to $(2\pi + \alpha)$, energy stored in L is delivered to load resistance R through the FD. As a consequence, power consumed by load is more in Fig. 6.3. It can, therefore, be concluded that power delivered to load, for the same firing angle, is more when FD is used. As volt-ampere input is almost the same in both Figs. 6.2 and 6.3, the input pf (= power delivered to load/input volt-ampere) with the use of FD is improved.

It is also seen from Figs. 6.2 (b) and 6.3 (b) that load current waveform is improved with FD in Fig. 6.3 (b). Thus the advantages of using freewheeling diode are

- (i) input pf is improved
- (ii) load current waveform is improved and
- (iii) as a result of (ii), load performance is better.

It may be seen from Fig. 6.3 (b) that freewheeling diode prevents the load voltage v_0 from becoming negative. Whenever load voltage tends to go negative, FD comes into play. As a result, load current is transferred from main thyristor to FD , allowing the thyristor to regain its forward blocking capability.

It is seen from Figs. 6.2 (b) and 6.3 (b) that supply current i_s taken from the source is unidirectional and is in the form of dc pulses. Single phase half-wave converter thus introduces a dc component into the supply line. This is undesirable as it leads to saturation of the supply transformer and other difficulties (harmonics etc.).

These shortcomings can be overcome to some extent by the use of single-phase fullwave circuits discussed in Art. 6.2.

2.4 Single phase Fully Controlled Converter

① midraht type with R load →

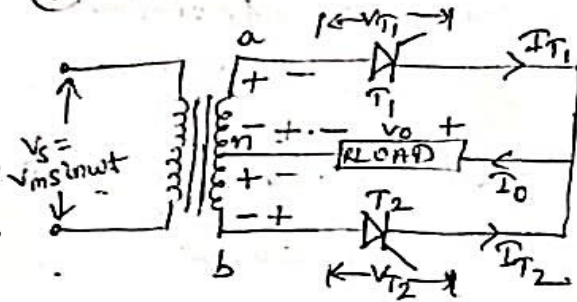

$$V_{an} = V_{nb}$$

$$V_{an} = -V_{bn}$$

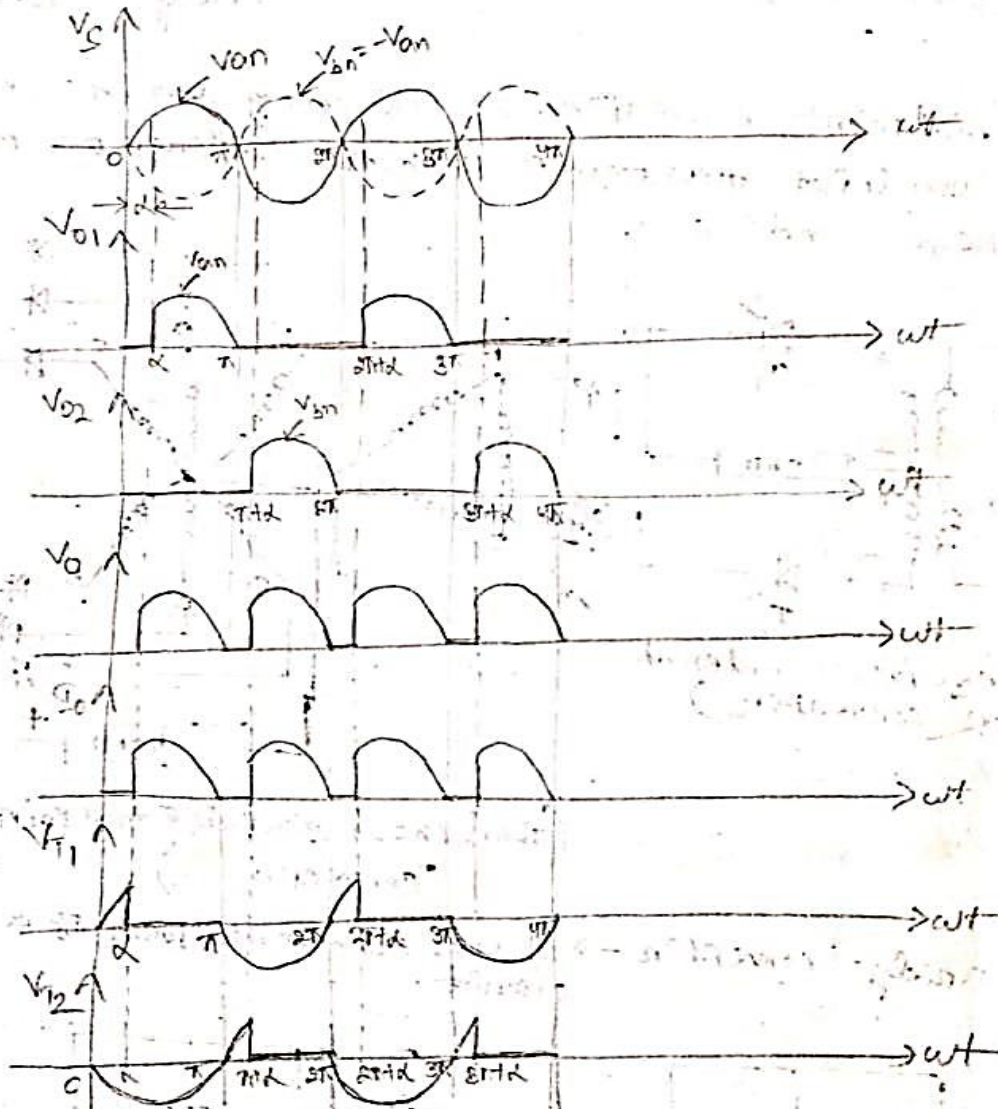

operation \rightarrow

During positive half cycle,

a +ve w.r.t b, V_{an} is in forward path

V_{bn} is in reverse path

anode of T_1 is +ve, cathode is -ve.

At $\omega t = \alpha$, T_1 is turned ON

T_2 remains OFF

$I_0 = I_{T1}$, flows in the +ve direction

$V_0 = V_{O1}$, forwards in the +ve direction

Here T_1 is called incoming SCR and

T_2 is outgoing SCR.

During -ve half cycle,

a -ve w.r.t b, V_{an} is in reverse path

V_{bn} is in forward path

anode of T_1 is -ve and cathode is +ve.

$\omega t = \pi$ to $(\pi + \alpha)$, $I_0 = 0$, $V_0 = 0$

$\omega t = (\pi + \alpha)$, T_1 is OFF and T_2 is ON

$I_0 = I_{T2}$ flows in the +ve direction

$V_0 = V_{O2}$ forwards in the +ve direction

$t_c = \frac{\pi}{\omega}$ sec.

$$V_0 = \frac{2}{2\pi} \int_{\alpha}^{\pi} V_m \sin \omega t \, d\omega t$$

$$V_0 = \frac{V_m}{\pi} (1 + \cos \alpha)$$

$$I_0 = \frac{V_0}{R} = \frac{V_m}{\pi R} (1 + \cos \alpha)$$

Single Phase Full wave bridge converter →

3 types ① uncontrolled converters:- uses only diodes and the level of dc o/p voltage cannot be controlled.

② half controlled converters:- uses mixture of diodes and thyristors or semi converters

and there is a limited control over the level of dc o/p voltage.

③ A fully controlled converter or full converter :- uses thyristors

only and there is wider control over the level of dc o/p voltage.

Half controlled bridge rectifier with R Load → is bridge type semi converter (R load)

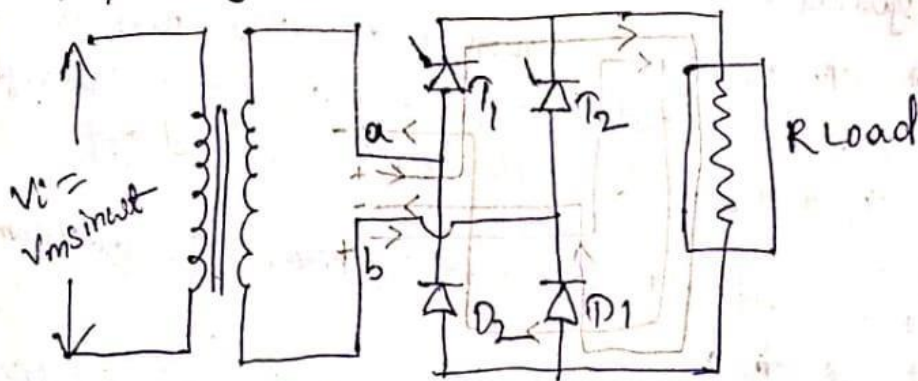

$$V_0 = \frac{V_m}{\pi} (1 + \cos \alpha)$$

$$I_0 = \frac{V_0}{R} = \frac{V_m}{\pi R} (1 + \cos \alpha)$$

During 1st half cycle,

a +ve w.r.t b, T_1, D_1 are forward biased

At $\omega t = \alpha$, T_1 is fired, v_o follows the i/p. Here T_1 is called the incoming SCR and D_1 is called incoming diode. During $\alpha \rightarrow \pi$, T_1, D_1 conducts load current. At $\omega t = \pi$, due to line commutation T_1 stops conducting.

During 2nd half cycle,

a -ve w.r.t b, T_2, D_2 are forward biased

At $\omega t = \pi + \alpha$, T_2 is fired & starts conducting. Here T_1, D_1 are outgoing SCR and diode and T_2, D_2 are incoming SCR and diode respectively. During $(\pi + \alpha) \rightarrow 2\pi$, T_2, D_2 conducts the load current.

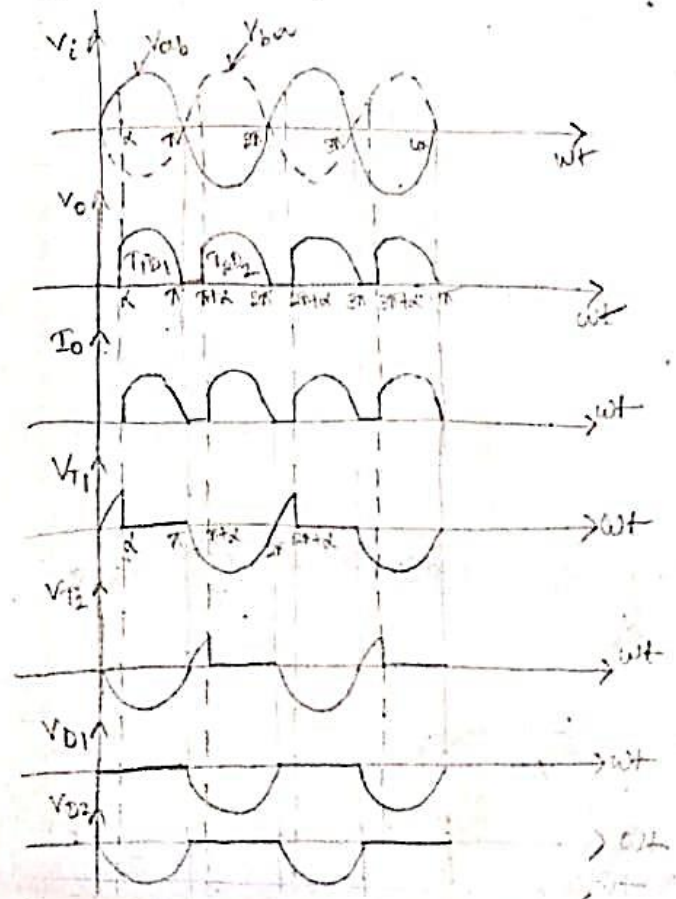

Fully controlled bridge rectifier with R-load \rightarrow

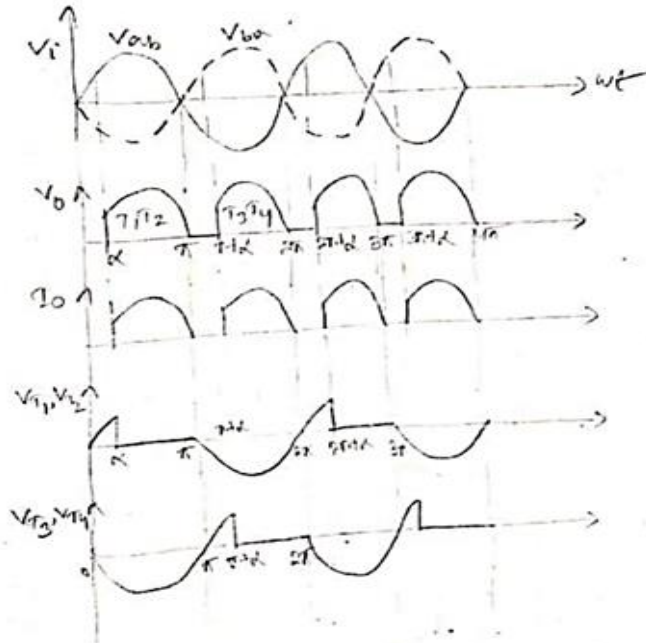
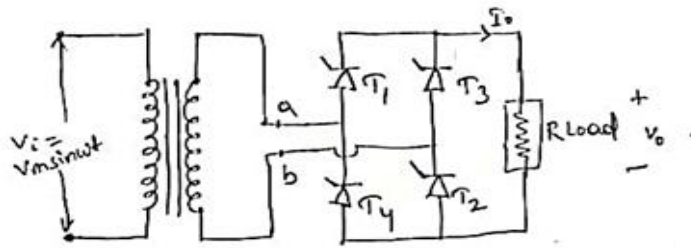

$$V_o = \frac{V_m}{\pi} (1 + \cos \alpha)$$

$$I_o = \frac{V_o}{R} = \frac{V_m}{\pi R} (1 + \cos \alpha)$$

$$t_c = \frac{\pi}{\omega} \text{ sec.}$$

Operation \rightarrow

During first half cycle, a is +ve w.r.t b.
 From $\omega t = 0 \rightarrow \alpha$, T_1, T_2 are forward biased but not conduct. $V_o = 0$. At $\omega t = \alpha$, T_1, T_2 are triggered.
 T_1 and T_2 starts conducting, T_3, T_4 will be off.

1 ϕ full wave bridge converter

(bulky controlled)

R - LOAD

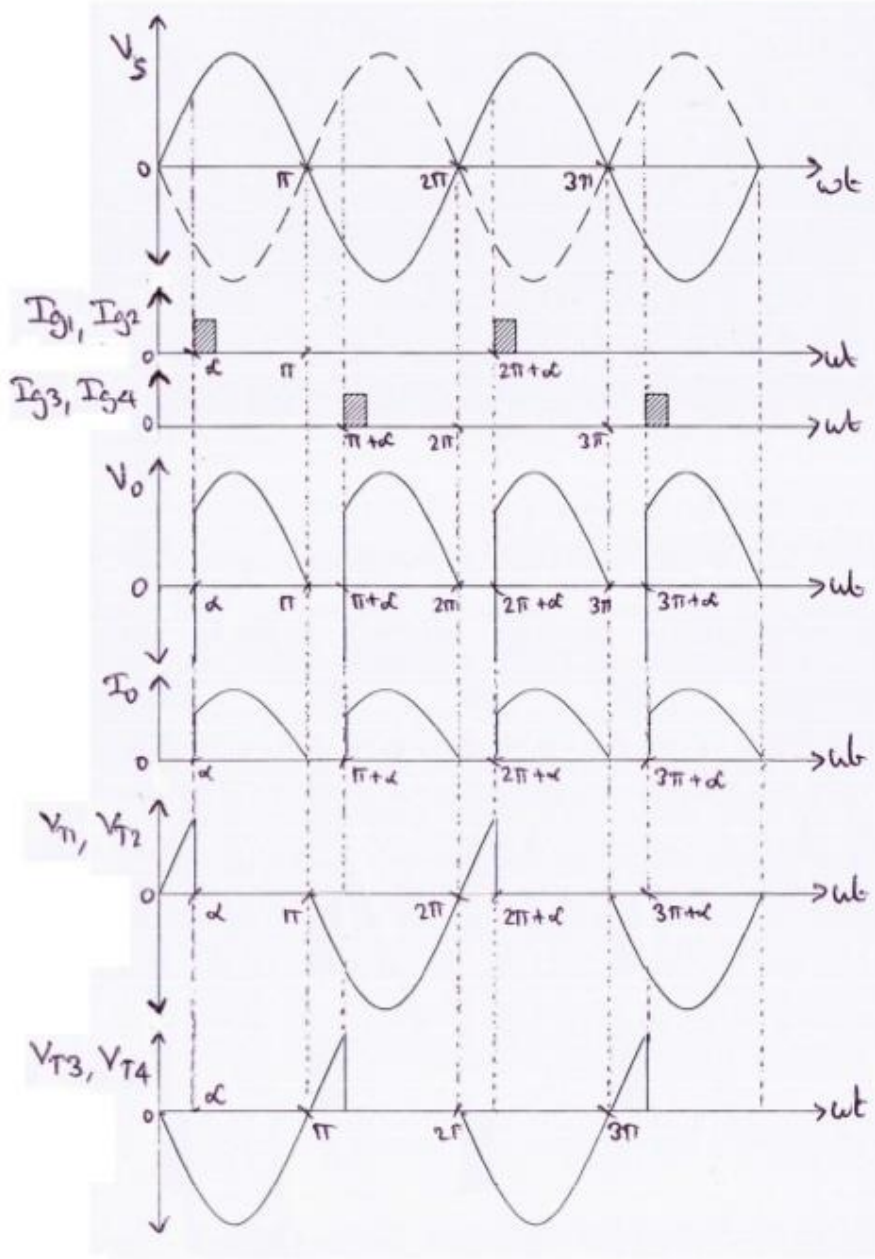
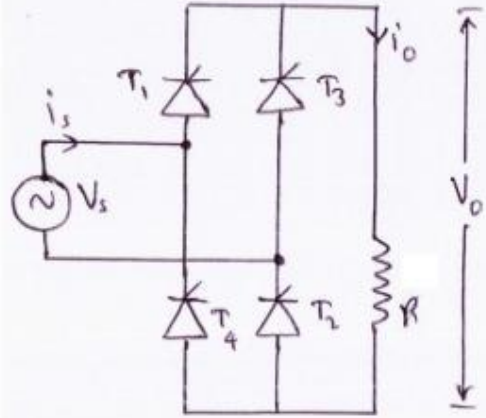

during second half cycle,

b is +ve w.r.t a, T_3, T_4 forward biased but not conducts
 T_1, T_2 stop conducting due to line commutation.

→ Line commutation technique called as natural commutation uses reverse voltage for turning off a thyristor i.e. in this type of rectifier by applying reverse bias across the thyristor and by reducing the anode current level below the holding current level we can turn off the thyristor.

from $\omega t = \pi \rightarrow (\pi + \alpha)$, T_1, T_2 will be OFF. T_3, T_4 not conduct due to absence of gate signal

from $\omega t = (\pi + \alpha) \rightarrow 2\pi$, T_3 and T_4 are triggered, T_1, T_2 will be OFF. T_3 and T_4 conduct due to gate signal. In this way the process goes on.

Fully controlled bridge rectifier with RL load →

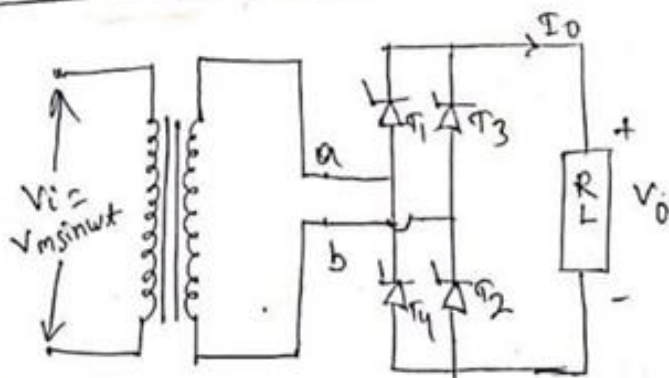

operation →

during first half cycle, a is +ve w.r.t b,

from $\omega t = 0 \rightarrow \alpha$, T_1 and T_2 are forward biased but not

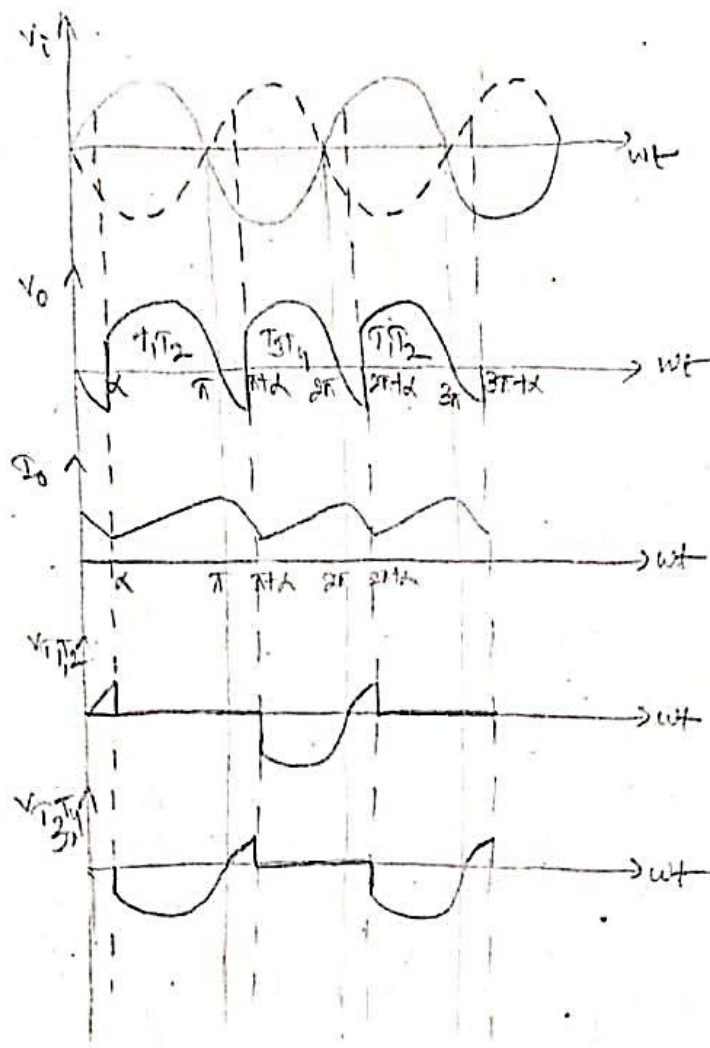

During second half cycle, b +ve w.r.t a,
 At $\omega t = \pi \rightarrow (\pi + \alpha)$, v_o follows v_i in reverse path. T_3 and T_4 are forward biased but not conducting. T_1 and T_2 still conduct due to load inductance.

At $\omega t = \pi + \alpha$, T_3 and T_4 are triggered, T_1 and T_2 will be off. T_3 and T_4 starts conducting.
 From $\omega t = \pi + \alpha \rightarrow 2\pi$, T_3 and T_4 conduct.

During second first half cycle, a +ve w.r.t b,
 $\omega t = 2\pi \rightarrow (2\pi + \alpha)$, T_3 and T_4 still conduct due to load inductance and here v_o follows v_i in reverse path.

At $\omega t = (2\pi n\alpha) \rightarrow 3\pi$, again T_1 and T_2 are triggered and T_3 and T_4 conduct due to gate signal. Here T_3 and T_4 will be off, and the process continues.

$$V_0 = \frac{2V_m}{\pi} \cos \alpha$$

$$I_0 = \frac{V_0}{R} = \frac{2V_m}{\pi R} \cos \alpha$$

$$t_c = \frac{\pi - \alpha}{\omega} \text{ sec.}$$

Fully controlled bridge rectifier with RL and flywheel diode \rightarrow

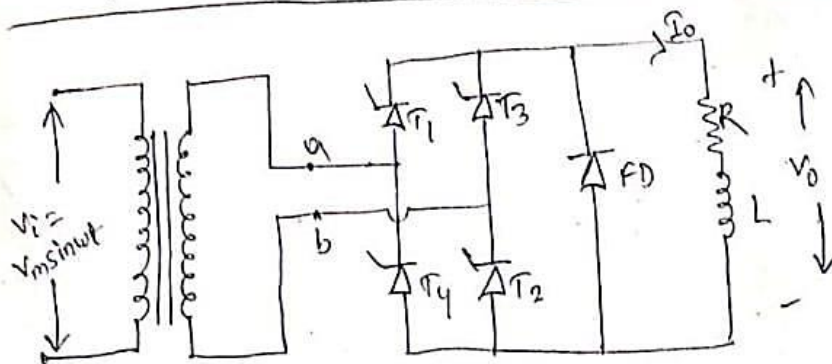

$$V_0 = \frac{V_m}{\pi} (1 + \cos \alpha)$$

$$I_0 = \frac{V_m}{\pi R} (1 + \cos \alpha)$$

$$t_c = \frac{\pi}{\omega} \text{ sec.}$$

operation \rightarrow

$v_i =$ i/p voltage

$v_o =$ o/p voltage

$I_0 =$ current flowing through load

$V_{T1}, V_{T2}, V_{T3}, V_{T4}$ are voltages across thyristors T_1, T_2, T_3, T_4 .

FD flywheel diode.

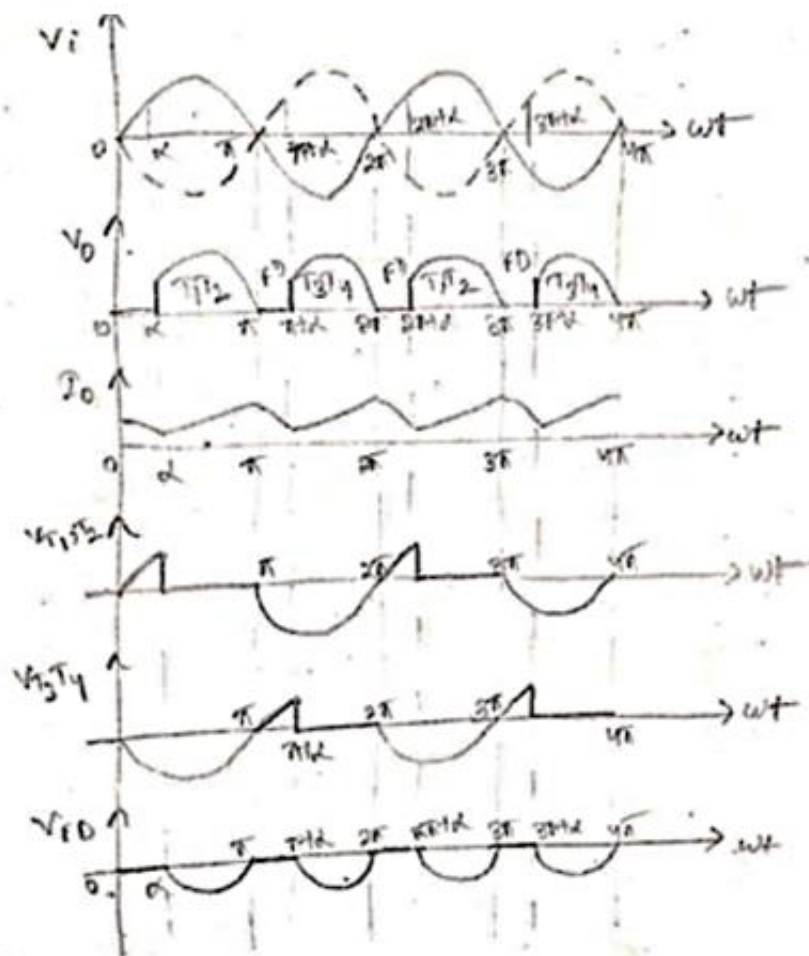

operation →

The operation of 1 ϕ fully controlled bridge rectifier with RL load and FD is similar to that of half controlled bridge rectifier feeding RL load with FD.

$\omega t = 0 \rightarrow \alpha$ $V_o = 0$, I_o falls from its peak value, $V_{FD} = 0$

$\omega t = \alpha \rightarrow \pi$ V_o follows V_i in forward path, I_o rises towards its peak. V_{FD} follows V_i in reverse path.

$\omega t = \pi \rightarrow \pi + \alpha$ $V_o = 0$, I_o falls from its peak value. $V_{FD} = 0$

$\omega t = \pi + \alpha \rightarrow 2\pi$ V_o follows V_i in forward path, I_o rises towards the peak. V_{FD} follows V_i in reverse path.

now $\omega t = 2\pi \rightarrow (2\pi + \alpha)$ and

$\omega t = (2\pi + \alpha) \rightarrow 3\pi$ the process continues.

2.5 Three phase half wave Controlled Converter with resistive load

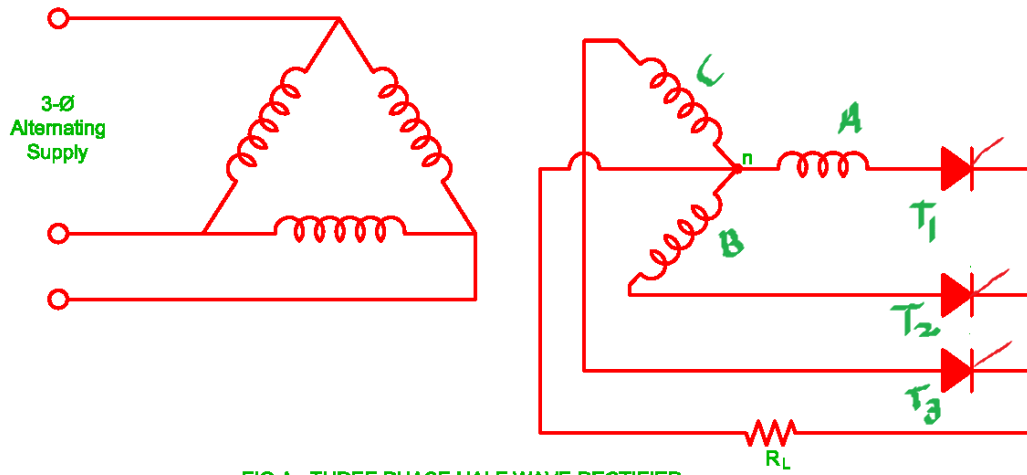

FIG A : THREE PHASE HALF WAVE RECTIFIER

For a 3 - phase half-wave controlled rectifier shown in Fig. A, the input phase voltages V_a , V_b , V_c have same amplitude and frequency with 120° phase shift as shown in Fig.2.

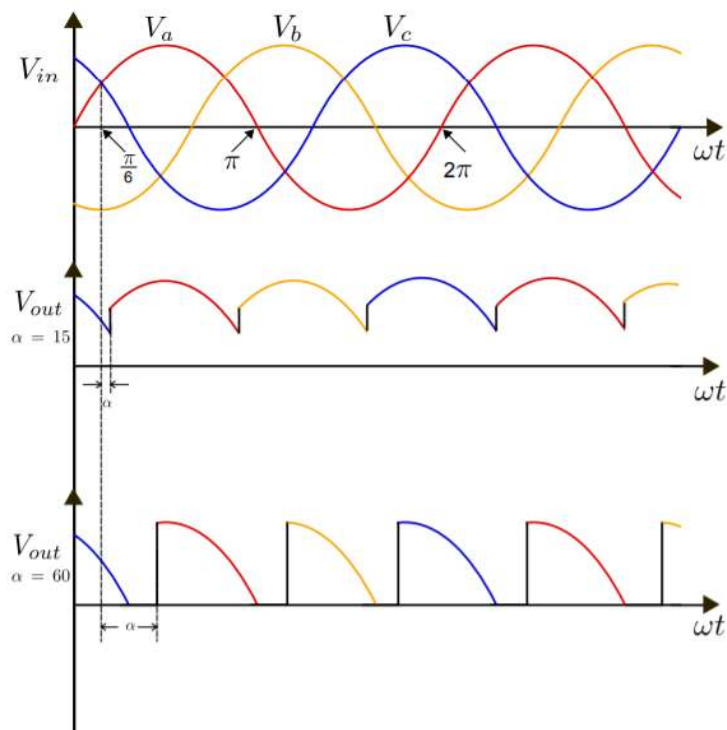
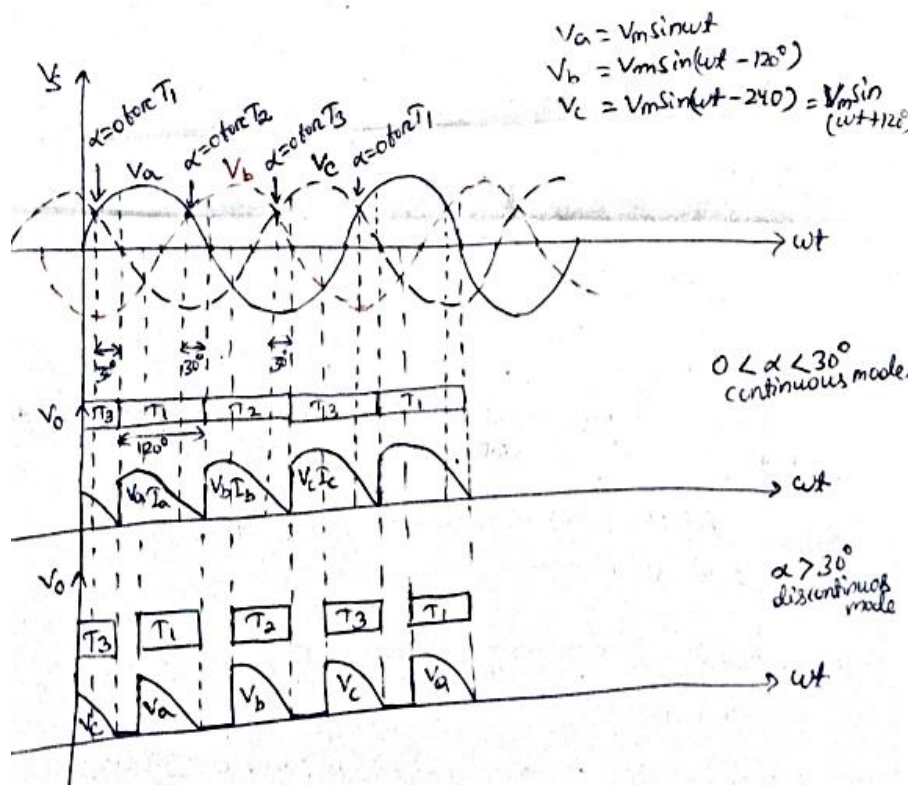
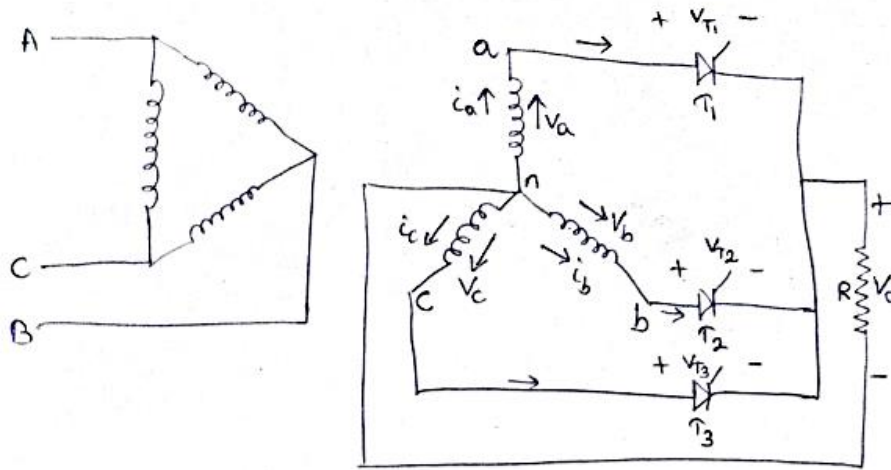

Figure 2: Output voltage waveform of 3 phase half-wave controlled rectifier



This converter is called 3-phase 3-pulse converter or 3-phase M-3 converter.

With reference to the above circuit diagram and waveforms, if firing angle is zero-degree, SCR T1 would begin conducting from $\omega t = 30^\circ$ to 150° , T2 from $\omega t = 150^\circ$ to 270° and T3 from $\omega t = 270^\circ$ to 390° and so on. In other words, firing angle for this controlled converter would be measured from $\omega t = 30^\circ$ for T1, from $\omega t = 150^\circ$ for T2 and from $\omega t = 270^\circ$ for T3. For zero degree firing

angle delay thyristor behaves as a diode. The operation of this converter is now described for $\alpha < 30^\circ$ and for $\alpha > 30^\circ$.

Firing angle $< 30^\circ$,

The output voltage waveform for firing angle less than 30° (say around 30°) is sketched, where T1 conducts from $\omega t = 30^\circ + \alpha$ to $\omega t = 150^\circ + \alpha$, T2 conducts from $\omega t = 150^\circ + \alpha$ to $\omega t = 270^\circ + \alpha$, T3 conducts from $\omega t = 270^\circ + \alpha$ to $\omega t = 390^\circ + \alpha$ and so on. Each SCR conducts for 120 degrees. The waveform of load current would be identical with voltage waveform.

Average value of output voltage

$$V_0 = \frac{3\sqrt{3}}{2\pi} V_{mp} \cos \alpha$$

$$V_0 = \frac{3}{2\pi} V_{ml} \cos \alpha$$

Where V_{mp} = maximum value of phase voltage

V_{ml} = maximum value of line voltage = $\sqrt{3} V_{mp}$

α = firing angle

$$I_0 = \frac{V_0}{R} = \frac{3}{2\pi R} V_{ml} \cos \alpha$$

Firing angle $> 30^\circ$,

When firing angle is more than 30° , T1 conducts from $\omega t = 30^\circ + \alpha$ to $\omega t = 180^\circ$, T2 conducts from $\omega t = 150^\circ + \alpha$ to $\omega t = 300^\circ$, T3 conducts from $\omega t = 270^\circ + \alpha$ to $\omega t = 420^\circ$ and so on. For R load when phase voltage V_0 reaches zero at $\omega t = 180^\circ$, current $i_0 = 0$, T1 is therefore turned off. Thus, T1 would conduct from $\omega t = 30^\circ + \alpha$ to $\omega t = 180^\circ$. Same is true for other SCRs. This shows that each SCR for Firing angle $> 30^\circ$ conducts for $(150^\circ - \alpha)$ only. This also implies that for R load maximum possible value of firing angle is 150° . The waveform of load current would be identical with voltage waveform.

Average value of output voltage

$$V_0 = \frac{3}{2\pi} V_{mp} [1 + \cos(\alpha + 30^\circ)]$$

Where V_{mp} = maximum value of phase voltage

$\alpha =$ firing angle

2.6 Three phase fully Controlled Converter with resistive load

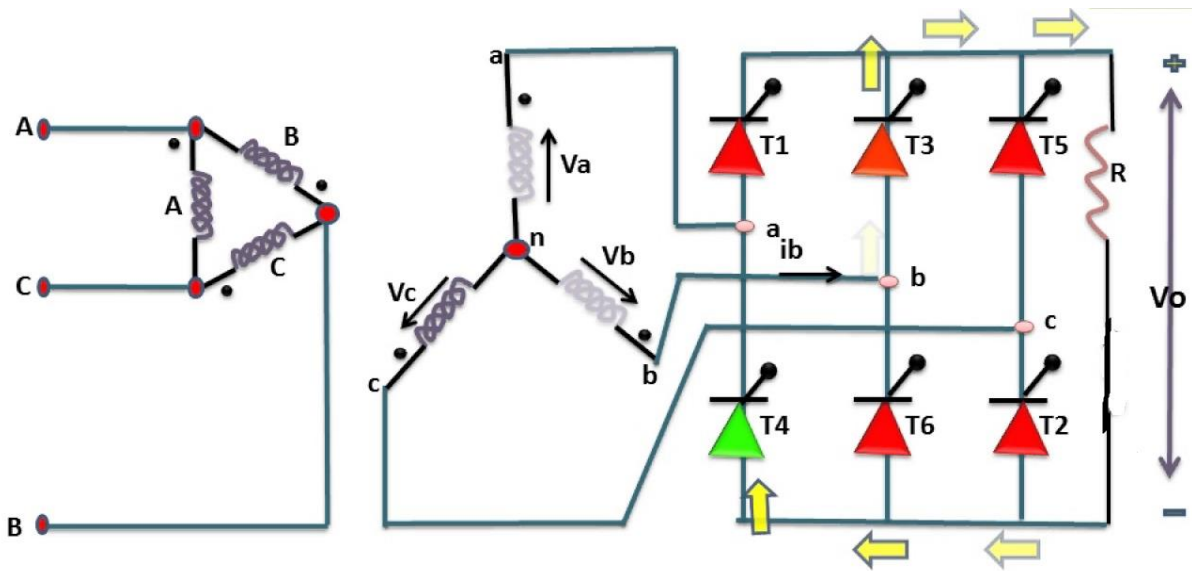

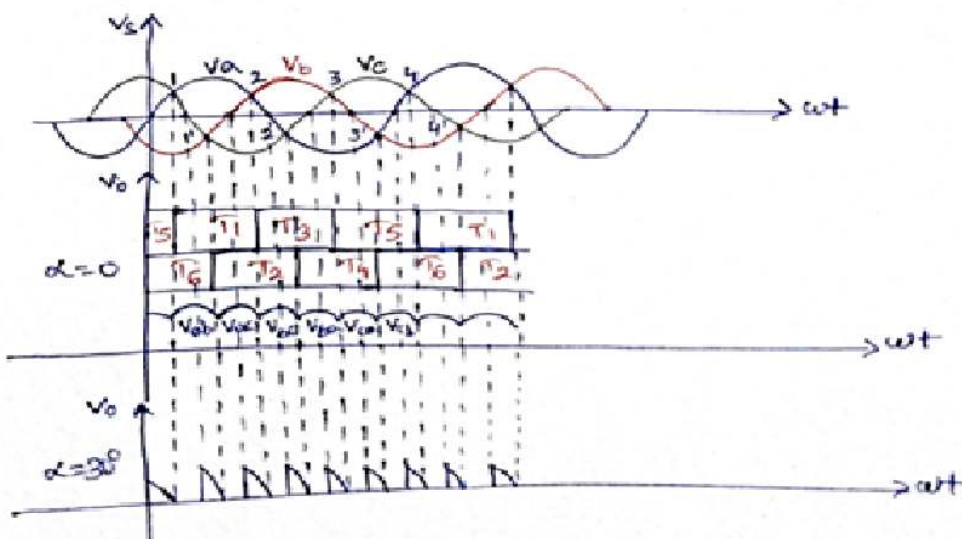
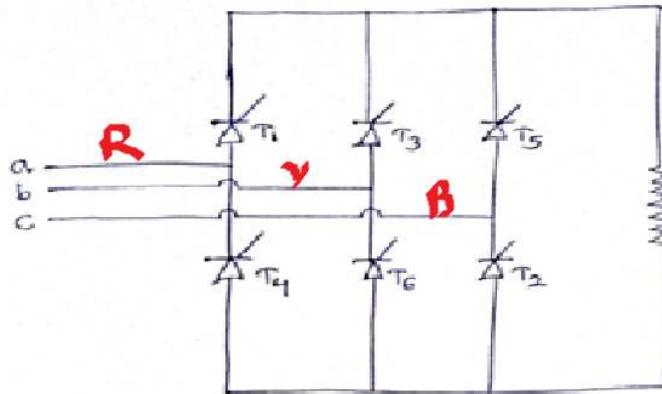

(3-phase 6-pulse)

The three-phase bridge rectifier circuit has three-legs, each phase connected to one of the three phase voltages. Alternatively, it can be seen that the bridge circuit has two halves, the positive half consisting of the SCRs S_1 , S_3 and S_5 and the negative half consisting of the SCRs S_2 , S_4 and S_6 . At any time when there is current flow, one SCR from each half conducts. If the phase sequence of the source be RYB, the SCRs are triggered in the sequence S_1 , S_2 , S_3 , S_4 , S_5 , S_6 and S_1 and so on.

The operation of the circuit is first explained with the assumption that diodes are used in place of the SCRs. The three-phase voltages vary as shown below.

Let the three-phase voltages be defined as shown below.

$$v_R(\theta) = E^* \sin(\theta), \quad v_Y(\theta) = E^* \sin(\theta - 120^\circ), \quad \text{and} \quad v_B(\theta) = E^* \sin(\theta + 120^\circ).$$

It can be seen that the R-phase voltage is the highest of the three-phase voltages when q is in the range from 30° to 150° . It can also be seen that Y-phase voltage is the highest of the three-phase voltages when q is in the range from 150° to 270° and that B-phase voltage is the highest of the three-phase voltages when q is in the range from 270° to 390° or 30° in the next cycle. We also find that R-phase voltage is the lowest of the three-phase voltages when q is in the range from 210° to 330° . It can also be seen that Y-phase voltage is the lowest of the three-phase voltages when q is in the range from 330° to 450° or 90° in the next cycle, and that B-phase voltage is the lowest when q is in the range from 90° to 210° . If diodes are used, diode D_1 in place of S_1 would conduct from 30° to 150° , diode D_3 would conduct from 150° to 270° and diode D_5 from 270° to 390° or 30° in the next cycle. In the same way, diode D_4 would conduct from 210° to 330° , diode D_6 from 330° to 450° or 90° in the next cycle, and diode D_2 would conduct from 90° to 210° . The positive rail of output voltage of the bridge is connected to the topmost segments of the envelope of three-phase voltages and the negative rail of the output voltage to the lowest segments of the envelope.

Period, range of q	SCR Pair in conduction
30° to 90°	S_1 and S_6
90° to 150°	S_1 and S_2
150° to 210°	S_2 and S_3
210° to 270°	S_3 and S_4
270° to 330°	S_4 and S_5
330° to 360° and 0° to 30°	S_5 and S_6

If SCRs are used, their conduction can be delayed by choosing the desired firing angle. When the SCRs are fired at 0° firing angle, the output of the bridge rectifier would be the same as that of the circuit with diodes. For instance, it is seen that D_1 starts conducting only after $q = 30^\circ$. In fact, it can start conducting only after $q = 30^\circ$, since it is reverse-biased before $q = 30^\circ$. The bias across D_1 becomes zero when $q = 30^\circ$ and diode D_1 starts getting forward-biased only after $q = 30^\circ$. When $v_R(q) = E \cdot \sin(q)$, diode D_1 is reverse-biased before $q = 30^\circ$ and it is forward-biased

when $q > 30^\circ$. When firing angle to SCRs is zero degree, S_1 is triggered when $q = 30^\circ$. This means that if a synchronizing signal is needed for triggering S_1 , that signal voltage would lag $v_R(q)$ by 30° and if the firing angle is α , SCR S_1 is

triggered when $\alpha = \alpha + 30^\circ$. Given that the conduction is continuous, the following table presents the SCR pair in conduction at any instant.

Period, range of α	SCR Pair in conduction
$\alpha + 30^\circ$ to $\alpha + 90^\circ$	S_1 and S_6
$\alpha + 90^\circ$ to $\alpha + 150^\circ$	S_1 and S_2
$\alpha + 150^\circ$ to $\alpha + 210^\circ$	S_2 and S_3
$\alpha + 210^\circ$ to $\alpha + 270^\circ$	S_3 and S_4
$\alpha + 270^\circ$ to $\alpha + 330^\circ$	S_4 and S_5
$\alpha + 330^\circ$ to $\alpha + 360^\circ$ and $\alpha + 0^\circ$ to $\alpha + 30^\circ$	S_5 and S_6

2.7 SINGLE PHASE AC REGULATOR OR CONTROLLER – PHASE ANGLE CONTROL

- AC voltage controllers are thyristor based devices which convert fixed alternating voltage directly to variable alternating voltage without change in frequency.
- Using these controllers, rms value of the voltage across the load is steplessly varied from a maximum value to zero.
- The simplest way to control AC voltage to the load is by using AC switch (bidirectional).
- The bi-directional conducting property can be achieved by simply connecting two unidirectional thyristors in inverse parallel to each other.

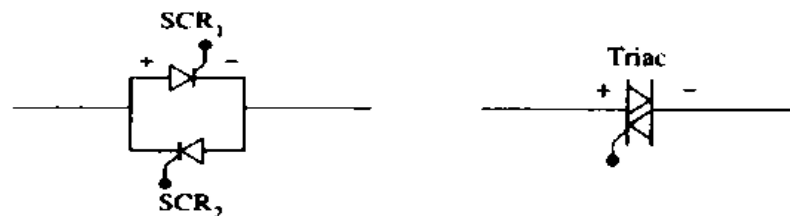

- AC voltage controllers are naturally commutated

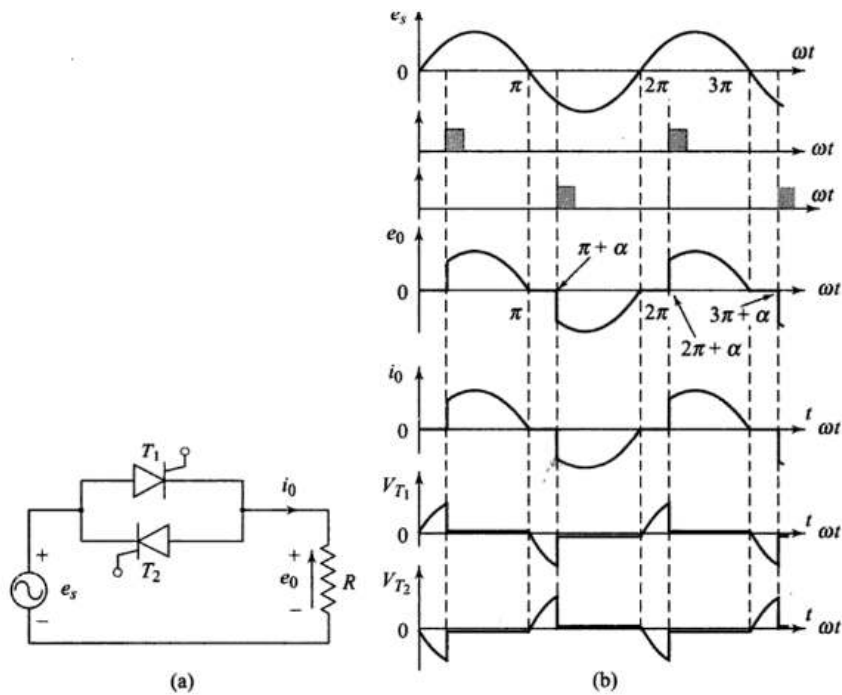
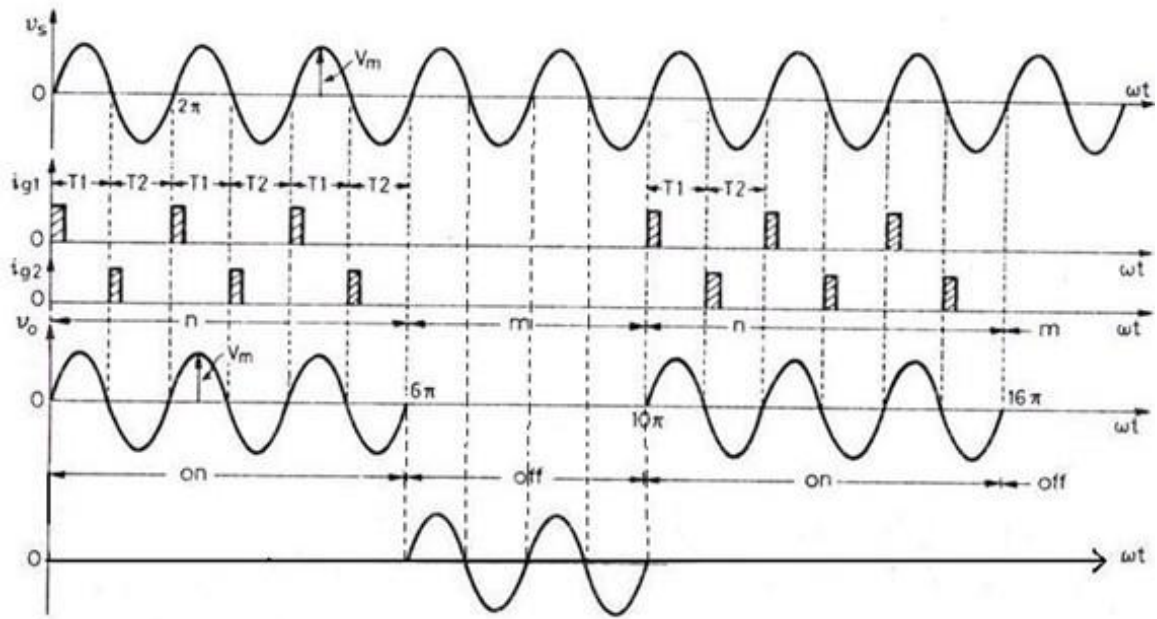

Fig.1 (a) Single-phase a.c. voltage controller with R load (b) voltage and current waveforms

Thyristors T1 and T2 are forward biased during positive and negative half-cycle, respectively. During positive half-cycle, T1 is triggered at a firing angle α . T1 starts conducting and source voltage is applied to load from α to π . At π , both e_0 , i_0 fall to zero. Just after π , T1 is subjected to reverse bias and it is, therefore, turned-off. During negative half-cycle, T2 is triggered at $(\pi+\alpha)$. T2 conducts from $(\pi+\alpha)$ to 2π . Soon after 2π , T2 is subjected to a reverse bias and it is, therefore, commutated. Load and source currents have the same waveform.

From zero to α , T1 is forward biased, therefore $V_{T1}=e_s$ as shown in Fig.1.b. From α to π , T1 conducts, V_{T1} is therefore about 1 V. After π , T1 is reverse biased by source voltage, therefore, $V_{T1}=e_s$ from π to $(\pi+\alpha)$. The voltage variation V_{T1} across T1 is shown in Fig.1.b. Similarly, the variation of voltage V_{T2} across thyristor T2 can be drawn. In Fig.1.b, voltage drop across thyristors T1 and T2 is purposely shown just to highlight the duration of reverse bias across T1 and T2. Examination of this figure reveals that for any value of α , each thyristor is reverse biased for π/ω seconds.

SINGLE PHASE AC REGULATOR OR CONTROLLER – INTEGRAL CYCLE CONTROL



1- On-Off Control (Integral Cycle Control)

The load power can be controlled by connecting the source to the load for few complete cycles then disconnecting the source from the load for another number of cycles, and repeating the switching cycle.

Suitable for systems with large time constants.

Average power to the load can be varied from 0% through 100%

Integral cycle control finds applications in heating loads and for motor speed control.

2.8 STEP UP & STEP-DOWN CHOPPER

STEP DOWN CHOPPER

A chopper is a static device that converts fixed DC input voltage to variable output voltage directly. Chopper are mostly used in electric vehicle, mini haulers. Chopper are used for speed control and braking. The systems employing chopper offer smooth control, high efficiency and have fast response.

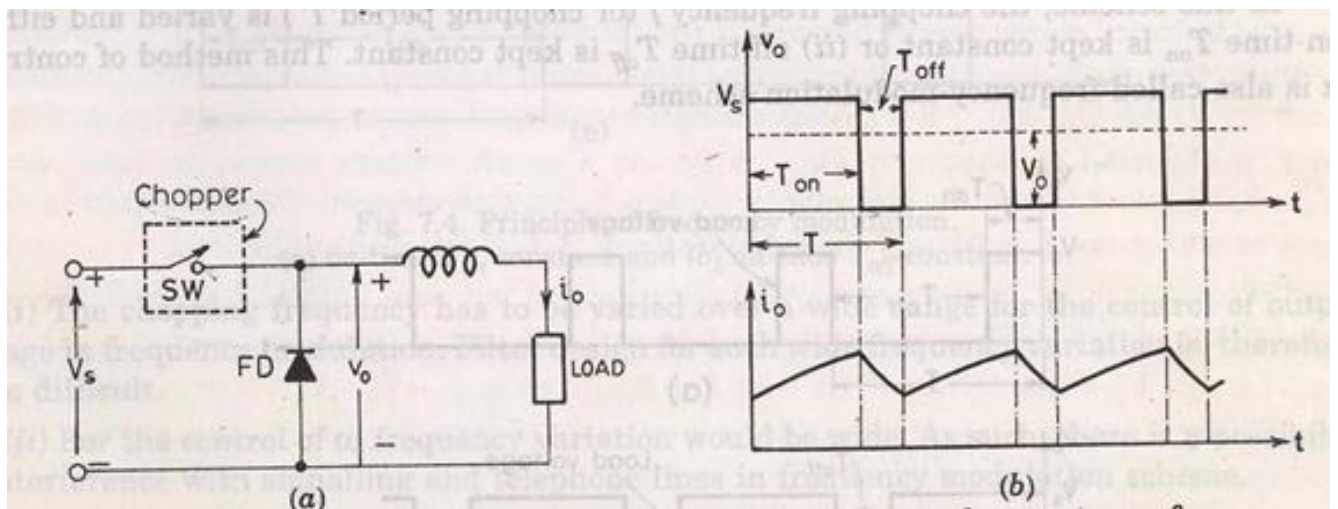

- Chopper is a static device that converts fixed dc i/p voltage to a variable dc o/p voltage directly.
- Chopper is a high speed on-off semiconductor switch that converts fixed dc input voltage to a variable dc o/p voltage by connecting source to load and disconnecting the load from source at a fast speed.

Application

- subway cars
- trolley buses, trolley cars
- battery operated vehicles
- battery charging
- crane hoists
- forklift trucks
- mine haulers
- Electric automobiles speed control & braking

AC link chopper

Here first dc is converted to ac by inverter. Ac is then stepped up or ^{stepped} down by a transformer which is then converted back to dc by a diode rectifier. Here conversion is in two stages (dc \rightarrow ac & ac \rightarrow dc) so this chopper is costly & less efficient.

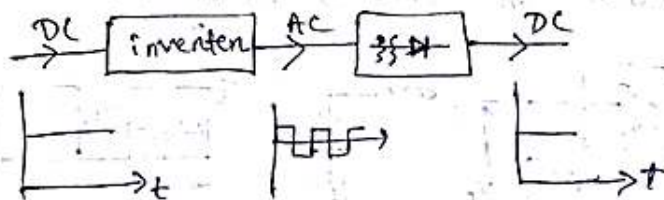

DC chopper

A chopper is a static device that converts fixed dc i/p voltage to variable dc o/p voltage directly.



Chopper represented by

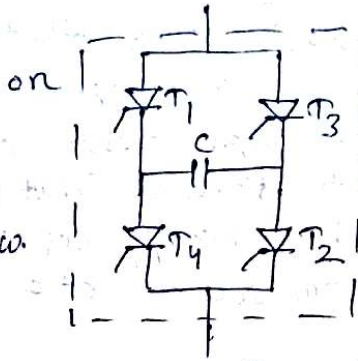
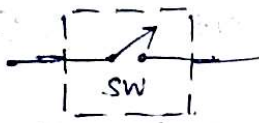

Chopper can be represented by a switch SW with an arrow. When the switch is off no current can flow. When the switch is on current flows in the direction of arrow only.

- Chopper is dc equivalent of an ac transformer having continuously variable turns ratio. Like a transformer chopper can be used to step down or step up the fixed dc input voltage.

Principle of Chopper operation: →

A chopper is a high speed on/off semiconductor switch. It connects source to load and disconnects the load from the source at a fast speed. In this manner a chopped load voltage is obtained from a constant dc supply of magnitude V_s . Chopper is represented by a switch SW inside a dotted rectangle, which may be turned on or turned off as desired.

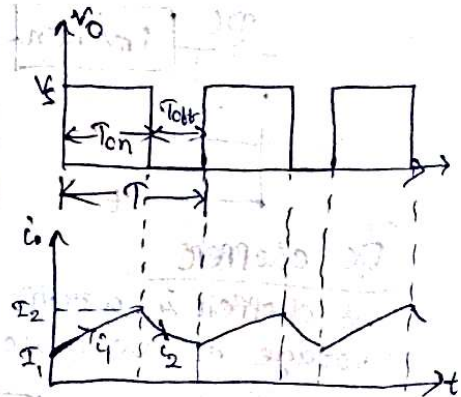
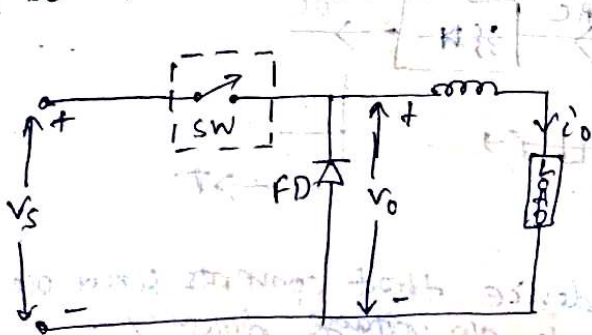

During the period T_{on} , chopper is on and load voltage is equal to source voltage V_s . During the interval T_{off} , chopper is off, load current flows through the FD, so that load terminals are short circuited by FD and load voltage is zero during T_{off} . In this manner chopped dc voltage is produced at the load terminals. The load current is continuous.

$$\text{Average load voltage, } V_0 = \frac{T_{on}}{T_{on} + T_{off}} V_s$$

$$V_0 = \frac{T_{on}}{T} V_s$$

$$V_0 = \alpha \cdot V_s$$

T_{on} = on time

T_{off} = off time

$T = T_{on} + T_{off}$ = Chopping period

$\alpha = \frac{T_{on}}{T}$ = duty cycle

- Hence the load voltage can be controlled by varying duty cycle α .
- load voltage is independent of load current.

$$V_0 = f \cdot T_{on} \cdot V_s$$

$f = \frac{1}{T}$ = chopping frequency.

equivalent ckt \rightarrow

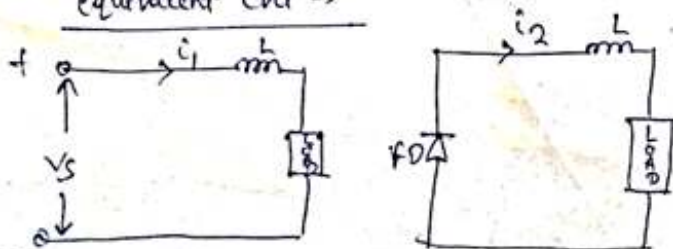

2.8.2 STEP UP CHOPPER

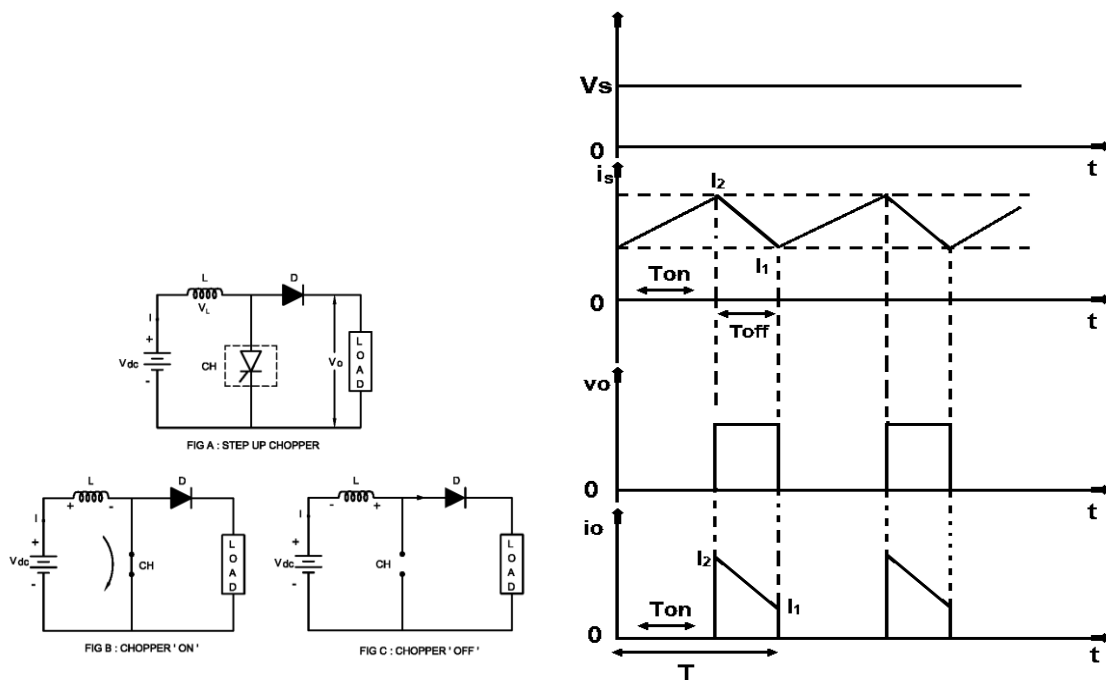

Working of Step up Chopper

Step up Chopper

The step up chopper is one in which output DC voltage is greater than the input DC voltage.

The basic diagram for the step up chopper is shown in the figure A.

When the chopper is switched ON during T_{ON} time, the energy stored in the inductor via path $V_{dc} - L - CH - V_{dc}$.

The direction of current passing through inductor is shown in the figure B when the chopper CH is switched on.

When chopper is switched OFF during T_{OFF} time, the current passing through inductor is zero and voltage across inductor is $L (di/dt)$.

The stored energy of inductor is transferred to the load.

The circuit diagram of step up chopper during chopper OFF time is shown in the figure C.

The load / output voltage is equal to

$$V_O = V_{dc} + V_L$$

$$= V_{dc} + L (di/dt)$$

When chopper is switch ON, the energy stored in the inductor is

$$W_i = V_{dc} I T_{ON} \dots \dots \dots (1)$$

When chopper is switched OFF, the energy stored in the inductor is transferred to the load.

$$W_o = (V_o - V_{dc}) I T_{OFF} \dots \dots (2)$$

If there are no losses in the system, the input energy is equal to output energy

$$V_{dc} I T_{ON} = (V_o - V_{dc}) I T_{OFF}$$

$$V_{dc} T_{ON} = V_o T_{OFF} - V_{dc} T_{OFF}$$

$$V_{dc} (T_{ON} + T_{OFF}) = V_o T_{OFF}$$

$$V_o = [(T_{ON} + T_{OFF}) / T_{OFF}] V_{dc}$$

$$V_o = [T / T_{OFF}] V_{dc}$$

OR

$$V_o = [T / (T - T_{ON})] V_{dc}$$

$$V_o = [1 / (1 - T_{ON} / T)] V_{dc}$$

$$V_o = [1 / (1 - K)] V_{dc}$$

When $K = 0$ (chopper is in OFF condition) $V_o = V_{dc}$

When $K = 1$ (chopper is in OFF condition) $V_o = \infty$

When the duty cycle lies in the range of $0 < K < 1$, the output voltage lies in the range of $V_{dc} < V_o < \infty$.

Application of DC Step up Chopper

The application of step up chopper is in the regenerative braking of DC Motor.

The output voltage is greater than the input voltage therefore the DC Motor works as DC generator and load current flows from load to supply side.

2.9 CONTROL MODES OF CHOPPER

Constant frequency operation:

1) The chopping period T is kept constant and on time is varied.

The pulse width modulation, the width of the pulse is varied.

2) Variable frequency operation, the chopping frequency f is varied.

Frequency modulation, either on time or off time is kept constant.

This type of control generate harmonics at unpredictable frequency and filter design is often difficult.

Control strategies \rightarrow

$$\boxed{\text{avg } V_o = \alpha \cdot V_s}$$

$$V_o = \frac{T_{on}}{T} \cdot V_s$$

$$V_o = f \cdot T_{on} \cdot V_s$$

The average o/p voltage V_o can be controlled through α by opening and closing the semiconductor switch periodically.

various control strategies of varying duty cycle α \rightarrow

① constant frequency system / PWM / TRC system

- ontime T_{on} is varied
- chopping frequency f or chopping period T is constant.
- variation of T_{on} means adjustment of pulsewidth.
- Also known as pulse width modulation or time ratio control system.

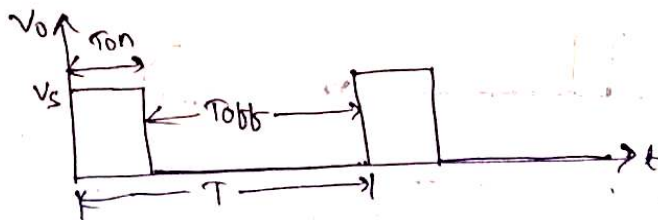

$$T_{on} = \frac{1}{4} T$$

$$\alpha = 0.25 \text{ or } 25\%$$

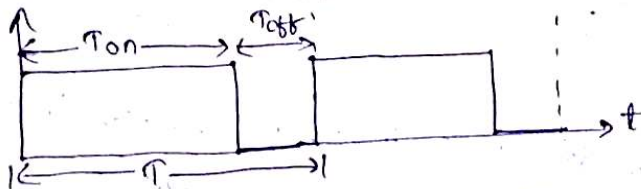

$$T_{on} = \frac{3}{4} T$$

$$\alpha = 0.75 \text{ or } 75\%$$

Limitation \rightarrow In PWM techniques, T_{on} cannot be reduced to near zero for most of the commutation circuits used in choppers, so that low range of α control is not possible in PWM. This can be achieved by increasing the chopping period or decreasing the chopping frequency.

② variable frequency system / frequency modulation

- chopping frequency \neq one chopping period T is varied and either T_{on} is constant or T_{off} is constant.

- Also called as frequency modulation scheme.

(a) T_{on} kept constant, T varied

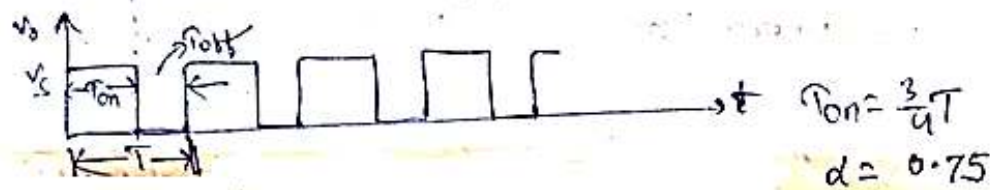

(b) T_{off} is kept constant and T varied

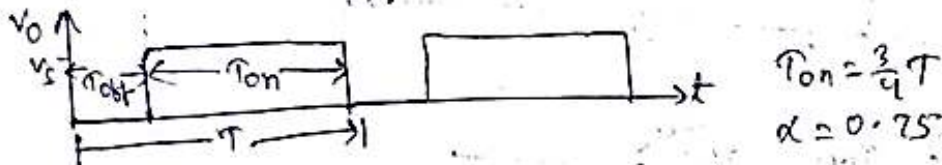
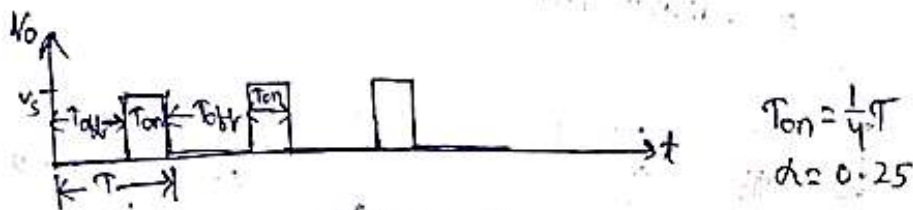

disadvantages →

- filter design for wide frequency variation is difficult.
- possibility of interference with signalling and telephone lines.
- longer off time may make the load current discontinuous.

TYPES OF CHOPPER:

FIRST QUADRANT OR TYPE A CHOPPER:

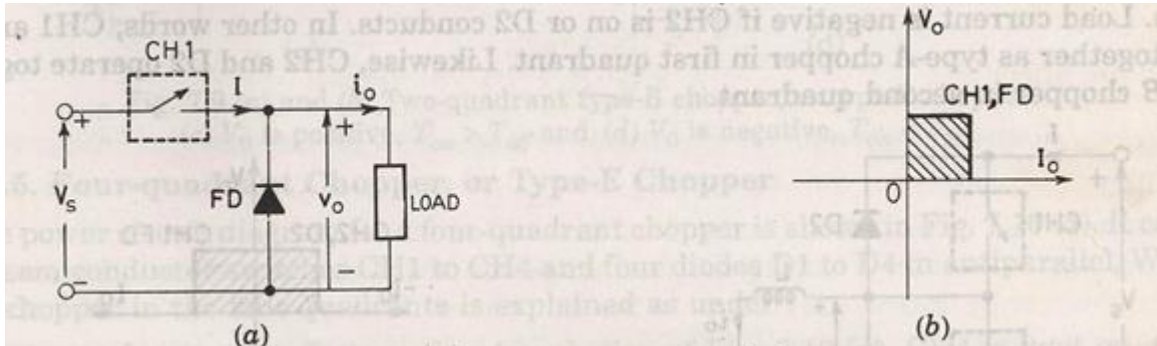

When switch ON

$$V_o = V_s$$

Current i_o flows in the same direction when switch off.

$$V_o = 0, i_o = 0$$

So, average value of both the load and the current are positive.

SECOND QUADRANT OR TYPE B CHOPPER:

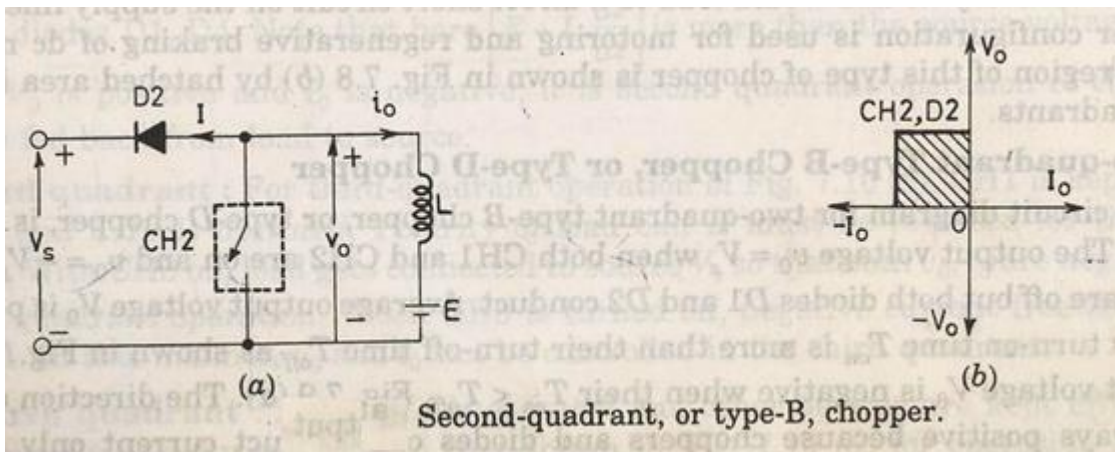

Second-quadrant, or type-B, chopper.

When switch is closed the load voltage E drives current through L and switch.

During T_{on} , L stores energy.

When switch off V_o exceeds source voltage V_s .

$$V_o = E + L \frac{di}{dt}$$

Diode D_2 is forward biased. power is fed back to supply. As V_o is more than source voltage. So such chopper is called step up chopper.

So current is always negative and V_o is always positive.

TWO QUADRANT TYPE A CHOPPER OR, TYPE C CHOPPER:

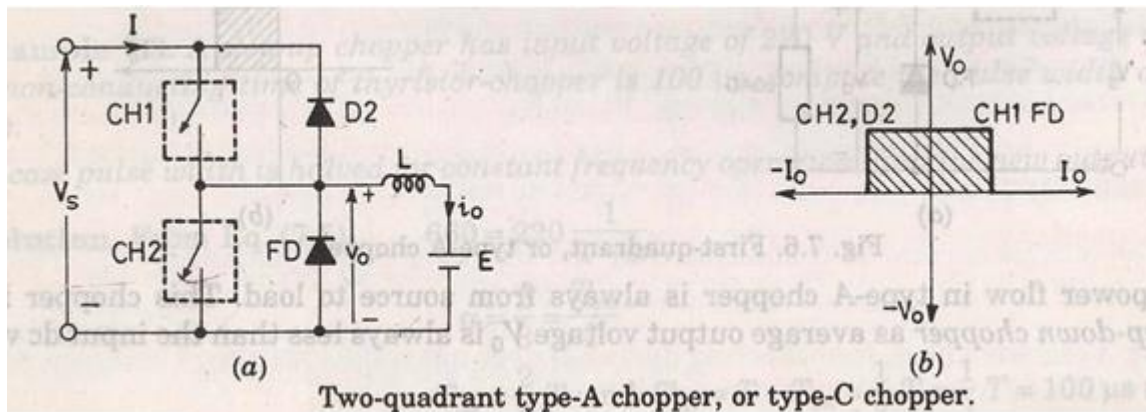

Both the switches never switch ON simultaneously as it lead direct short circuit of the supply.

Now when sw2 is closed or FD is on the output voltage V_o is zero.

When sw1 is ON or diode D conducts output voltage is V_o is $+V_s'$

CURRENT ANALYSIS:

When CH1 is ON current flows along i_o . When CH1 is off current continues to flow along i_o as FD is forward biased. So i_o is positive.

Now when CH2 is ON current direction will be opposite to i_o . When sw2 is off D2 turns ON. Load current is $-i_o$. So average load voltage is always positive.

Average load current may be positive or negative.

TWO QUADRANT TYPE B CHOPPER, OR TYPE D CHOPPER:

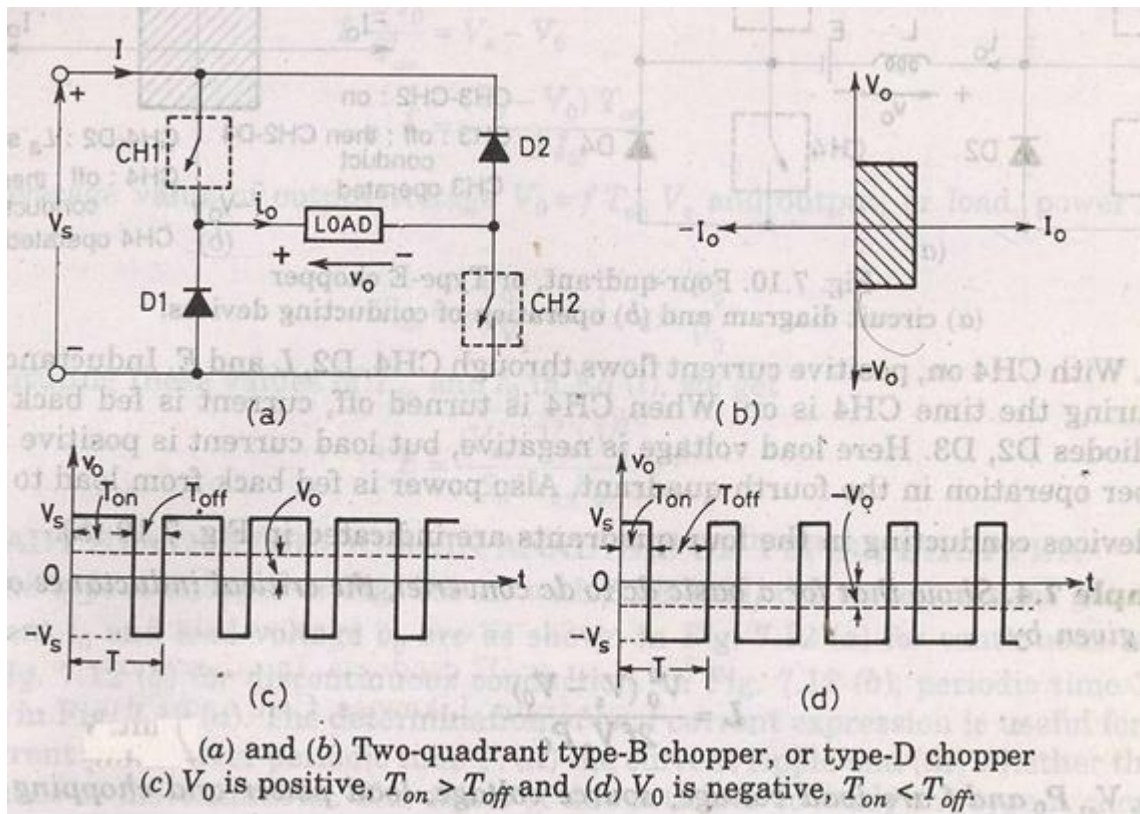

When CH1 and CH2 both are on then $V_0 = V_s$.

When CH1 and CH2 are off and D1 and D2 are on $V_0 = -V_s$.

The direction of current is always positive because chopper and diode can only conduct in the direction of arrow shown in fig. Average voltage is positive when $T_{on} > T_{off}$

2.10 FOUR QUADRANT CHOPPER, OR TYPE E CHOPPER

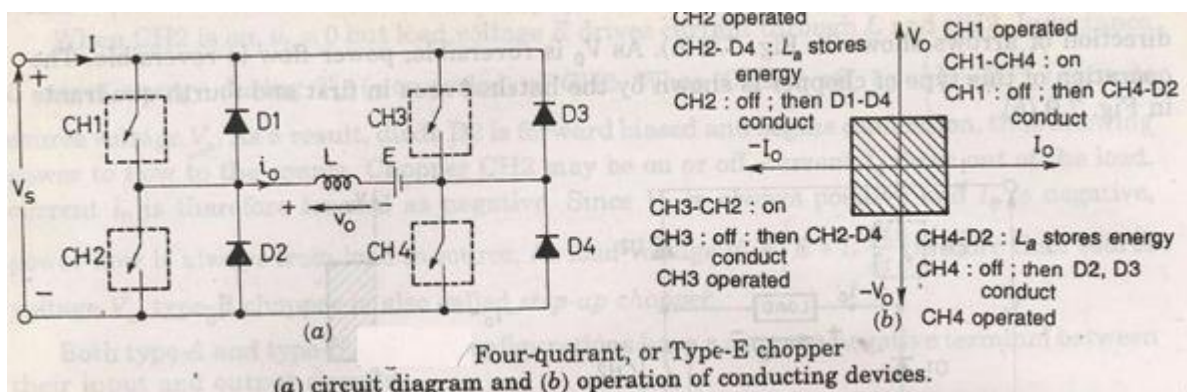

FIRST QUADRANT:

CH4 is kept ON

CH3 is off

CH1 is operated

$V_0 = V_s$

$i_0 = \text{positive}$

when CH1 is off positive current free wheels through CH4, D2
so V_0 and I_2 is in first quadrant.

SECOND QUADRANT:

CH1, CH3, CH4 are off.

CH2 is operated.

Reverse current flows and I is negative through L CH2 D4 and E.

When CH2 off D1 and D4 is ON and current i_d fed back to source. So

$E + L \frac{di}{dt}$ is more than source voltage V_s .

As i_0 is negative and V_0 is positive, so second quadrant operation.

THIRD QUADRANT:

CH1 OFF, CH2 ON

CH3 operated. So, both V_0 and i_0 is negative.

When CH3 turned off negative current freewheels through CH2 and D4.

FOURTH QUADRANT:

CH4 is operated other are off.

Positive current flows through CH4 E L D2.

Inductance L stores energy when current fed to source through D3 and D2. V_0
is negative.

MODULE-3

INVERTERS

The device that converts dc power into ac power at desired output voltage and frequency is called an inverter.

Single phase voltage source inverters:

The inverter is a power electronic converter that converts direct power to alternating power. By using this inverter device, we can convert fixed dc into variable ac power which has a variable frequency and voltage. Secondly from this inverter, we can vary the frequency i.e we will be able to generate the 40HZ, 50HZ, 60HZ frequencies as of our requirement. If the dc input is a voltage source then the inverter is known as VSI (Voltage Source Inverter). The inverters need four switching devices whereas half-bridge inverter needs two switching devices. The bridge inverters are of two types they are half-bridge inverter and full-bridge inverter. This article discusses the half-bridge inverter.

The inverter is a device that converts a dc voltage into ac voltage and it consists of four switches whereas half-bridge inverter requires two diodes and two switches which are connected in anti-parallel. The two switches are complementary switches which means when the first switch is ON the second switch will be OFF. Similarly, when the second switch is ON the first switch will be OFF.

Where R_L is the resistive load, $V_s/2$ is the voltage source, S_1 and S_2 are the two switches, i_0 is the current. Where each switch is connected to diodes D_1 and D_2 parallelly. In the above figure, the switches S_1 and S_2 are the self-commutating switches. The switch S_1 will conduct when the voltage is positive and current is negative, switch S_2 will conduct when the voltage is negative, and the current is negative. The diode D_1 will conduct when the voltage is positive and current is positive, diode D_2 will conduct when the voltage is negative, and the current is positive.

Case 1 (when switch S_1 is ON and S_2 is OFF): When switch S_1 is ON from a time period of 0 to $T/2$, the diode D_1 and D_2 are in reverse bias condition and S_2 switch is OFF.

Applying KVL (Kirchhoff's Voltage Law)

$$V_s/2 - V_0 = 0$$

Where output voltage $V_0 = V_s/2$

Where output current $i_0 = V_0/R = V_s/2R$

In case of supply current or switch current, the current $i_{S1} = i_0 = V_s/2R$, $i_{S2} = 0$ and the diode current $i_{D1} = i_{D2} = 0$.

Case 2 (when switch S_2 is ON and S_1 is OFF): When switch S_2 is ON from a time period of $T/2$ to T , the diode D_1 and D_2 are in reverse bias condition and S_1 switch is OFF.

Applying KVL (Kirchhoff's Voltage Law)

$$V_s/2 + V_0 = 0$$

Where output voltage $V_0 = -V_s/2$

Where output current $i_0 = V_0/R = -V_s/2R$

In case of supply current or switch current, the current $i_{S1} = 0$, $i_{S2} = i_0 = -V_s/2R$ and the diode current $i_{D1} = i_{D2} = 0$.

The single-phase half-bridge inverter output voltage waveform is shown in the below figure.

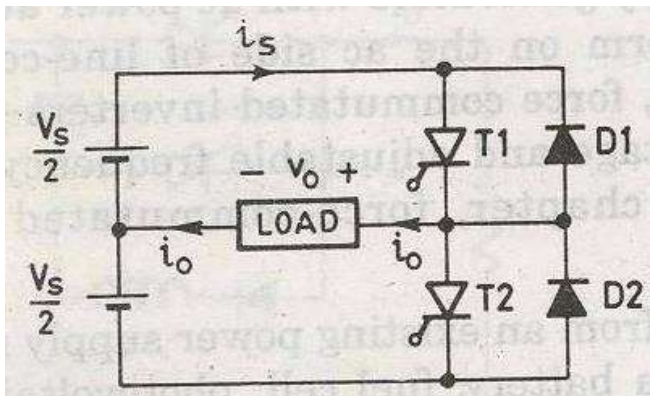

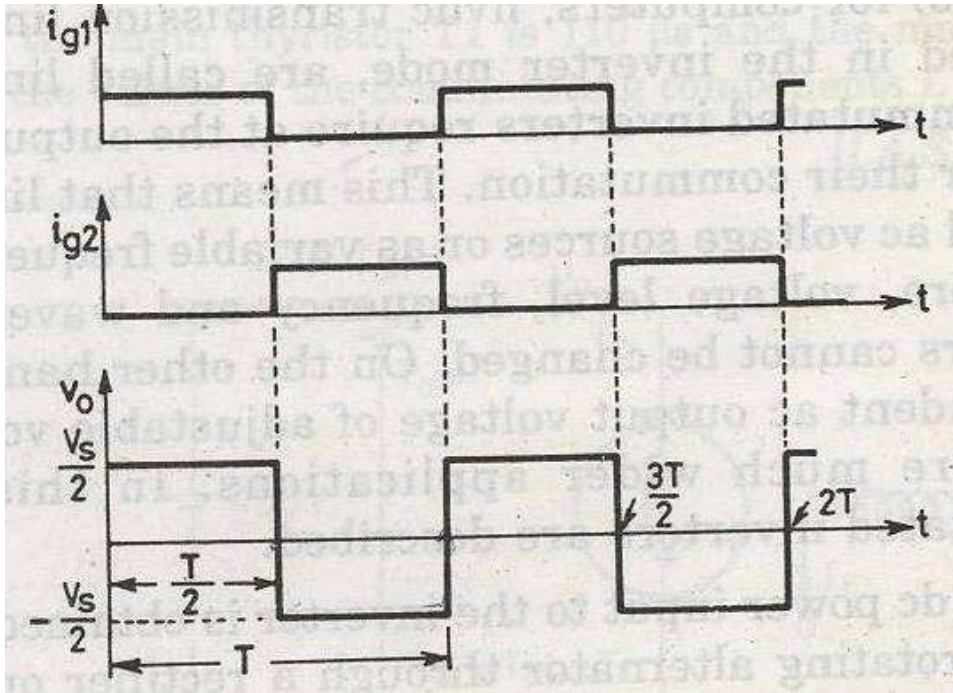

Single phase full bridge inverter:

The power circuit of a single-phase full bridge inverter comprises of four thyristors T1 to T4, four diodes D1 to D1 and a two wire DC input power source V_s . Each diode is connected in antiparallel to the thyristors viz. D1 is connected in anti-parallel to T1 and so on. The power circuit diagram of a single-phase full bridge inverter is shown in the figure below.

The working principle of single-phase full bridge inverter is based on the sequential triggering of thyristors placed diagonally opposite. This means, for half of time period, thyristors T3 & T4 will be triggered while for the remaining half of time period, T1 & T2 will be triggered. Only two thyristors are turned ON in half of the time period.

Carefully observe the waveform of the gating signal. You will notice that thyristors T1 & T2 are triggered simultaneously for a time $T/2$. Therefore, load is connected to source through T1 & T2 and hence, the load voltage is equal to the source voltage with positive polarity. This is the reason; the load voltage is shown positive & equal to V_s in the output voltage waveform.

As soon as the gate signal (i_{g1} & i_{g2}) are removed, T1 and T2 get turned OFF. However, at the same instant gate signal (i_{g3} & i_{g4}) are applied and hence, T3 & T4 are turned ON. When T3 & T4 are conducting, load gets connected to the source. The load voltage magnitude is again V_s but with reverse polarity. This is the reason; the output voltage is shown negative in the voltage waveform.

To summarize,

For the time $0 < t \leq (T/2)$, thyristors T1 & T2 conducts and load voltage $V_o = V_s$.

For the time $(T/2) < t \leq T$, thyristors T3 & T4 conducts and load voltage $V_o = -V_s$.

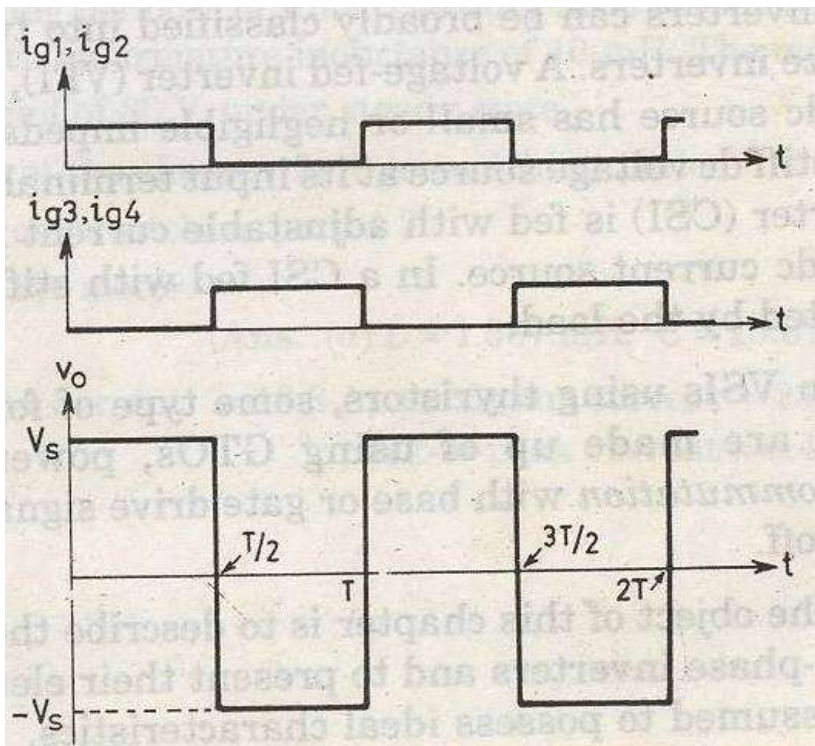
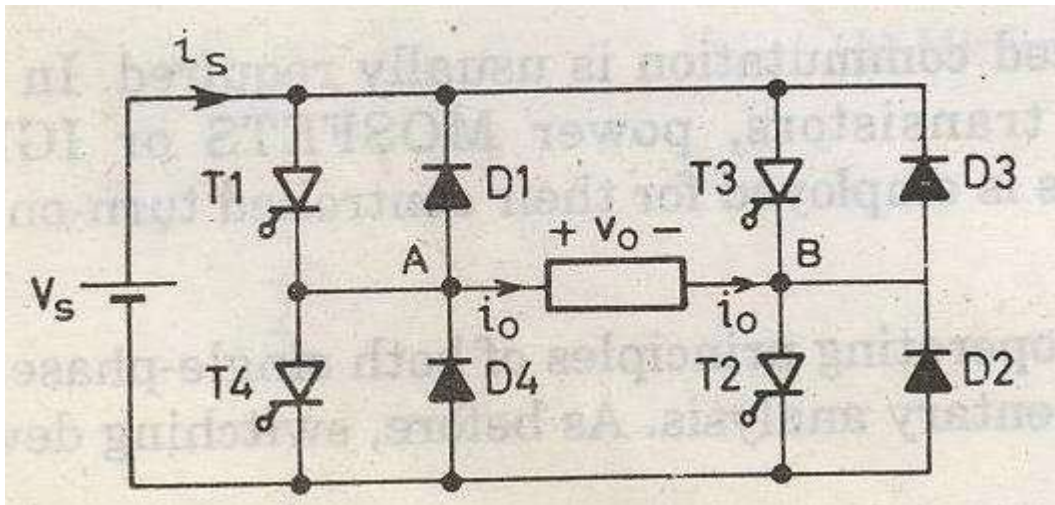

Purpose of Diodes D1 to D4:

If the load is purely resistive, there is no need to put diode D1 to D4 as the output voltage and current are always in phase. But unfortunately, for loads other than purely resistive, the load current (i_o) will not be in phase with the load voltage (v_o). For such case, the diode connected in anti-parallel with the thyristor will allow the current to flow when main thyristor is turned off. When these diode conducts, the energy is fed back to the DC source and hence, these diodes (D1 to D4) are called flyback diode.

Comparison between Half & Full Bridge Inverters:

The major difference between the single phase half and full bridge inverter is that former requires a three wire DC input source while the latter requires two wire DC source. Another difference between the two type of inverters are tabulated below:

Half Bridge Inverter	Full Bridge Inverter
It comprises of two thyristors and two free-wheeling diodes.	It consists of four thyristors and four flyback diodes.
The magnitude of load / output voltage is half of the magnitude of input DC source.	The magnitude of load voltage is equal to the magnitude of DC input source. This means, the magnitude of output voltage is twice the magnitude of load voltage for half bridge inverter.
The main drawback of this inverter is the requirement of three wire DC input supply.	This drawback of half bridge inverter is overcome by full bridge inverter as it requires two wire DC source.
-	The output power of full bridge inverter is four times that of for half bridge inverter.

SERIES INVERTER: IT'S WORKING, OPERATION AND WAVEFORM

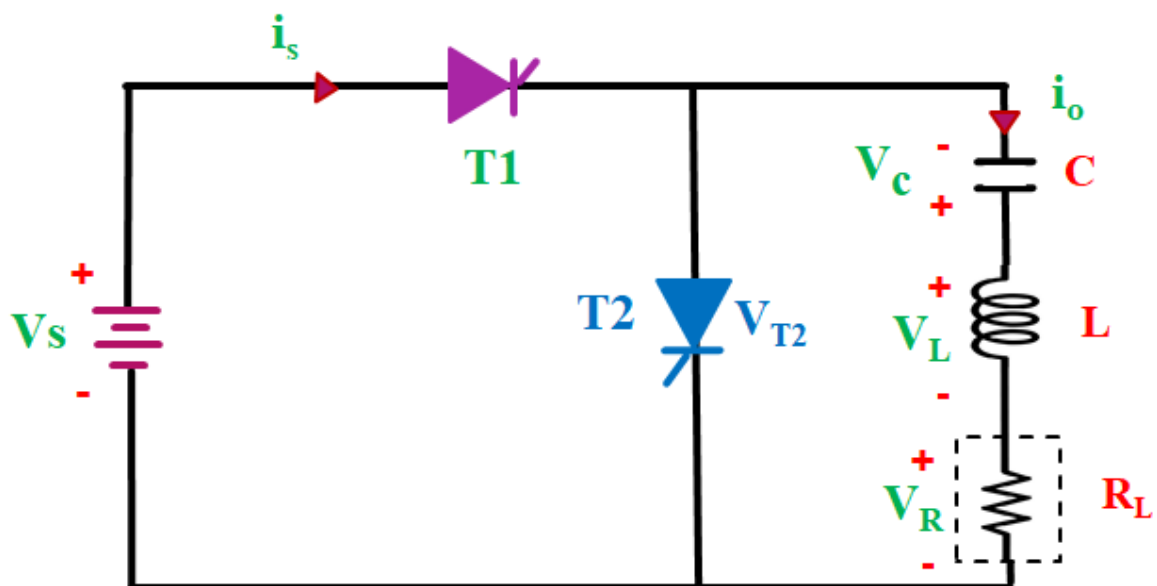

Inverter is an electronic circuit which converts DC power into AC power. The inverter circuit in which the commutating elements L and C are connected in series with the load to form an under damped circuit is called a series inverter. This circuit is also called load commutated or self-commutated inverter.

Operation of Series inverter

The whole operation is divided into three modes:

Mode-I (T1 on and T2 off): In this mode we give firing pulse to thyristor T1 so, T1 get turned on and T2 thyristor is turned off initially. So, current flow from supply V_sT1.....load.....back to V_s .

The nature of the load current is alternating due to under damped circuit. So, this time capacitor (C) starts charging gradually from $-V_s$ to its max voltage. This time inductor (L) also get charge. When the load current becomes maximum the voltage across capacitor becomes $+V_s$. When the load current becomes zero at point the voltage across capacitor becomes $+2V_s$. Then the load current becomes zero the thyristor T1 automatically turns off at point a.

Mode- II (T1 and T2 both off): This time thyristor T1 turns off because the load current becomes zero from point a to b. In this time duration the thyristor T1 and T2 are turned off and voltage across capacitor becomes equal to $+2V_s$.

Mode III (T1 off and T2 on): In this mode we give firing pulse to thyristor T2. So, T2 get turned on. In this time capacitor start discharging its energy from $+2V_s$ to $-V_s$ through thyristor T2 and R – L circuit. Due to capacitor discharging reverse current flow across the load. Now at point C thyristor T2 turns off automatically due to load current becomes zero. The thyristor T2 turns off during point C to D and thyristor T1 again turns on. In this way cycle repeat.

Now, we see in the waveform the time duration ab and cd is called as *dead zone*.

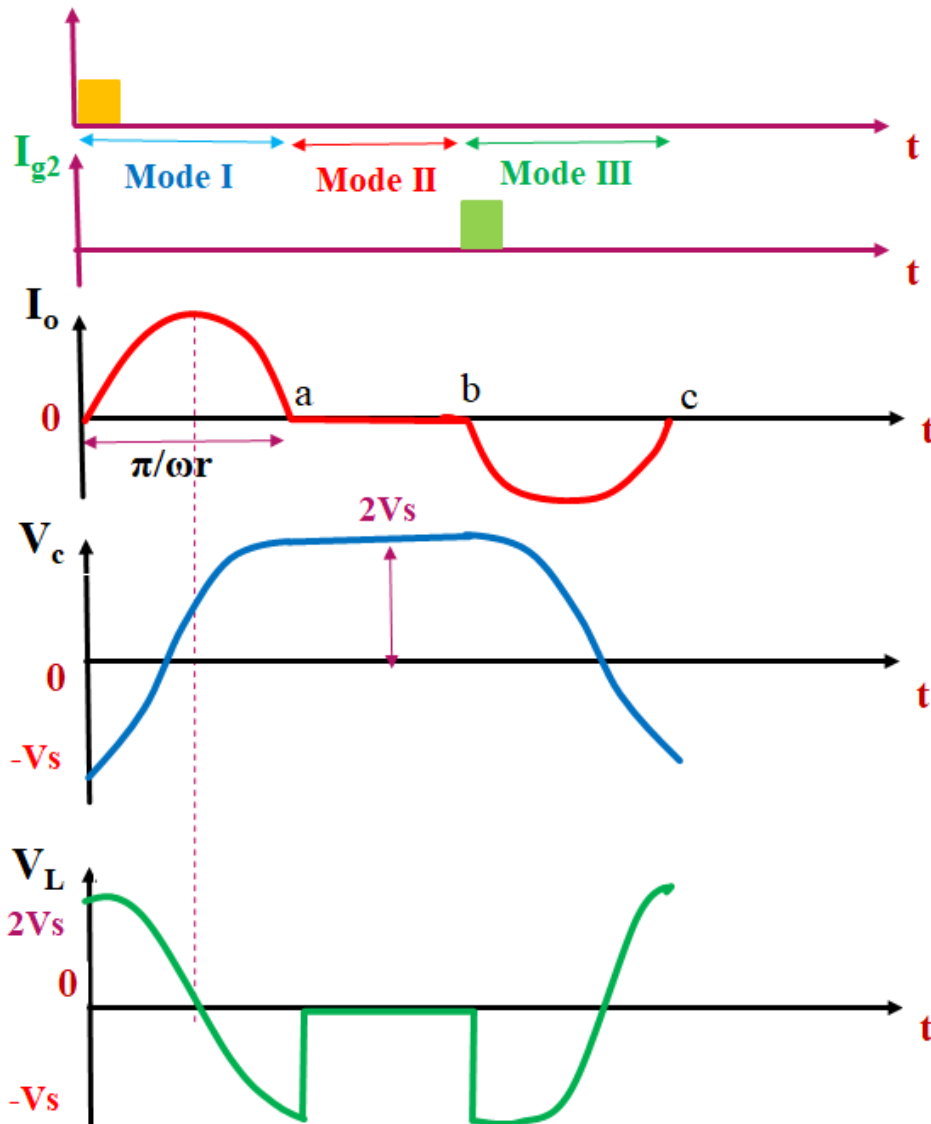

Application of Series Inverter

Series Inverter is basically used in high frequency applications (200 Hz to 100 KHz) because it generates high frequency sinusoidal waveform.

This circuit is called load commutated inverter because the load component (L and C) is responsible to turned off the thyristor. It is called self-commutated inverter because in this circuit anode current itself become zero resulting the thyristor turned off.

The Circuit Diagram of Series Inverter is shown in the figure. It consists of two thyristors (T1 and T2). The thyristor T1 and T2 are turn on appropriately to get the output voltage of desired frequency. This circuit consist of L and C connected in series with load (R).

Initially we considered that thyristor T2 is turned off and the polarity across capacitor is shown in figure.

PARALLEL INVERTER: IT'S BASICS, OPERATION AND WAVEFORM

Parallel inverter is an electronic circuit which converts DC power into AC power. The inverter circuit in which the commutating component C (capacitor) is connected in parallel with the load via transformer called a parallel inverter. This circuit is also called Push-pull inverter.

Parallel Inverter working is similar to the class B commutation. Parallel inverter has important role in Uninterrupted Power Supply (UPS).

Parallel inverter circuit consist of two thyristor T1 and T2, a transformer, inductor L and a commutating component C. Capacitor (C) is connected in parallel with the load via transformer therefore it is called a parallel inverter. And inductor (L) is connected in series with supply to make the source current constant. Here we also use a center -tapped transformer. Centre tapping is done in the primary winding of transformer so, primary winding is divided into two equal halves ao and ob

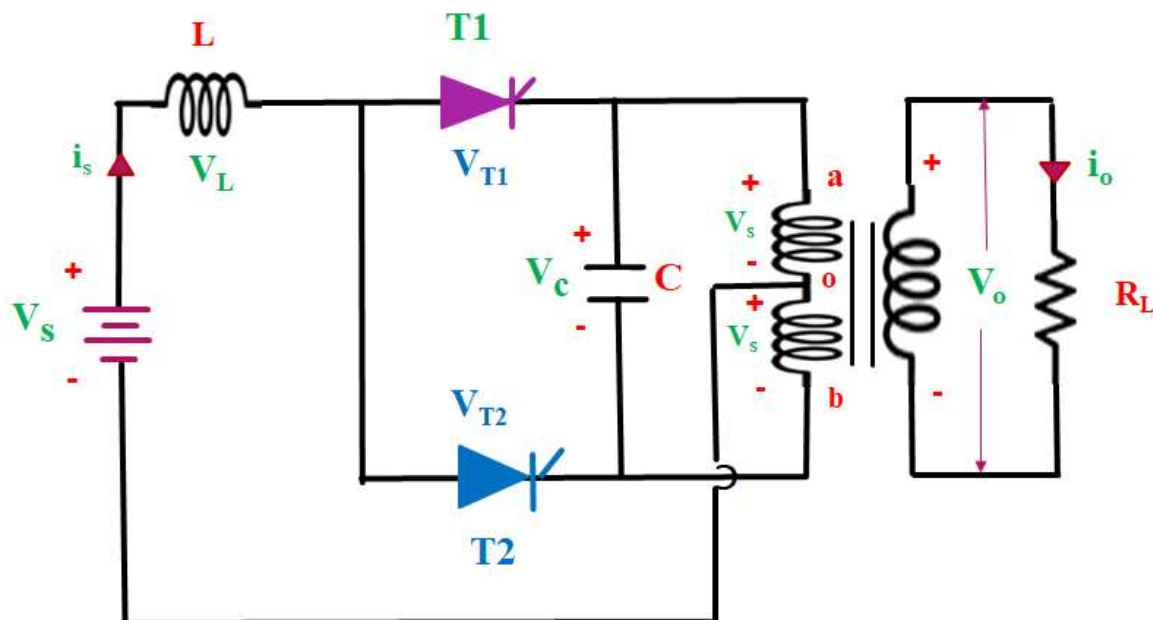

Operation of Parallel Inverter:

The operation is divided into four modes:

Mode I ($0 < t < t_1$): In this mode we give firing pulse to thyristor T1 and T1 get turned on and T2 is turned off. Current flow from Supply V_s T1.... a_o (upper half of primary winding) back to V_s . As a result, V_s voltage is induced across upper as well as lower half of the primary winding of transformer. And V_s voltage is induced in secondary winding.

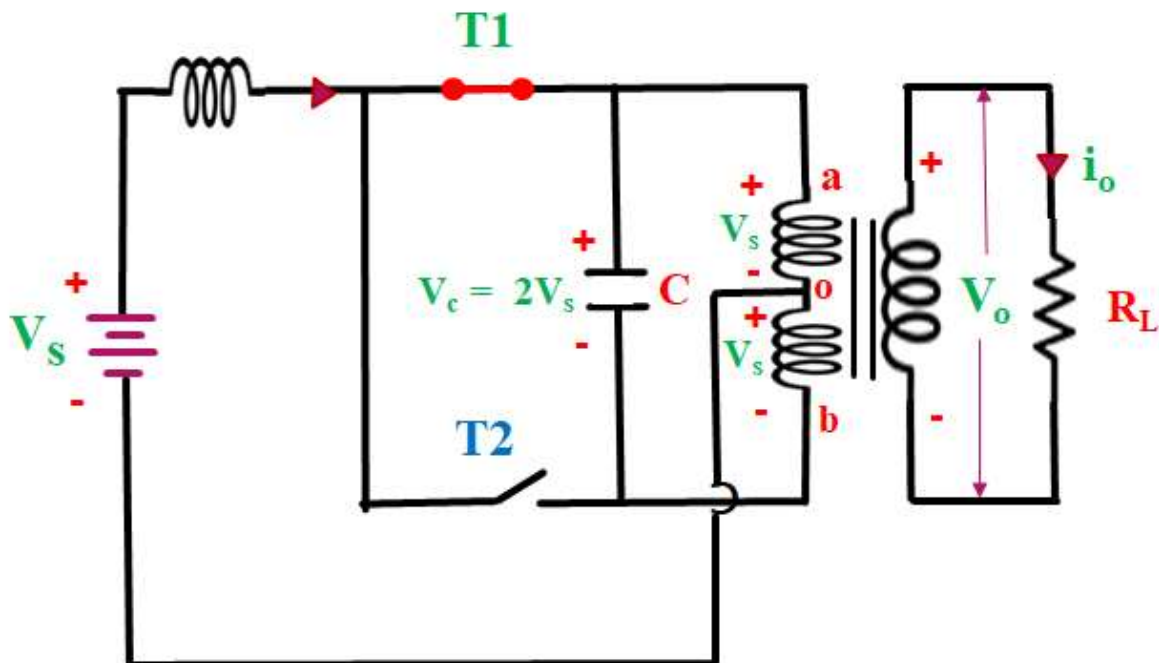

So, output voltage across load is V_s .

So, the total voltage across primary winding is $2V_s$. Here capacitor is connected in parallel with primary winding therefore capacitor charge with $2V_s$ voltage with upper plate is positive and lower plate is negative.

Mode II ($t_1 < t < t_3$): In this duration we give firing pulse to thyristor T2 and T2 get turned on. At this time capacitor start discharging through T1 therefore T1 turned OFF. This time current flow from supply V_s T2.... b_o (lower half of primary winding) back to V_s .

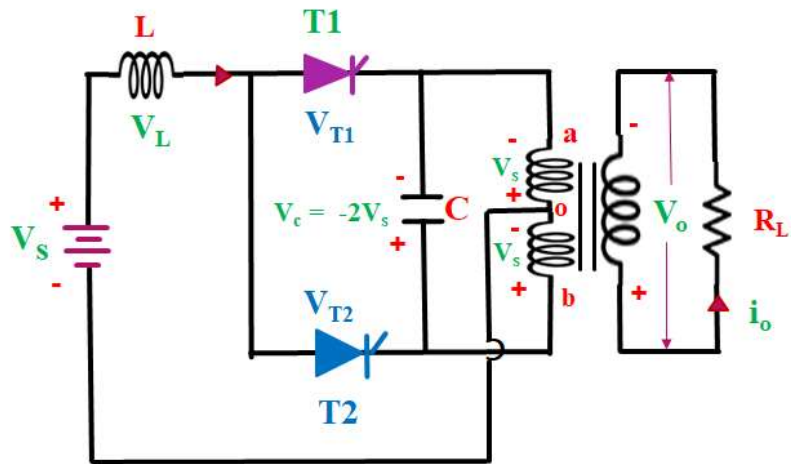

Now this time capacitor charged with upper plate is negative, from $+2V_s$ at $t=t_1$ to $-2V_s$ at $t=t_2$. Load voltage also changes from V_s at $t=t_1$ to $-V_s$ at $t=t_2$. After $t=t_2$ voltage across capacitor is maintain constant $-2V_s$ between $t=t_2$ to t_3 .

So, load voltage is also constant $-V_s$.

Mode III ($t_3 < t < t_4$): In this mode again, we give firing pulse to thyristor T1 and T1 get turned on. At this time capacitor start discharging through T2 therefore T2 turned OFF. This time current flow from supply V_s T1.... ao (upper half of primary winding) back to V_s . So, the total voltage across primary winding is $2V_s$.

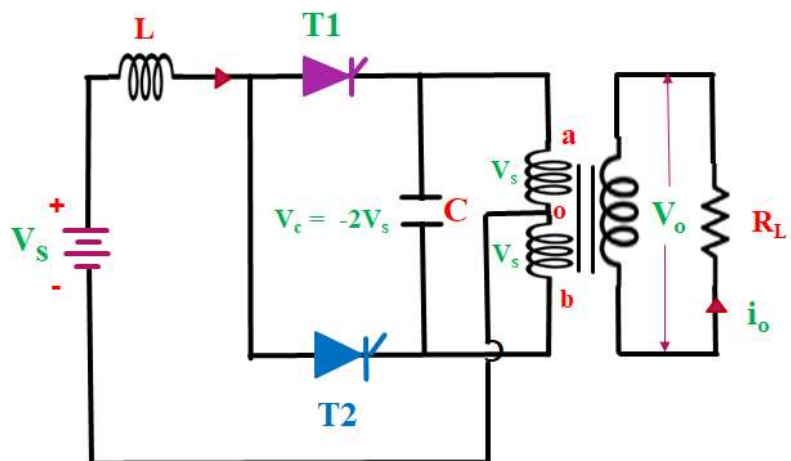

Now this time capacitor charged with upper plate is positive, from $-2V_s$ at $t=t_3$ to $+2V_s$ at $t=t_4$. Load voltage also changes from V_s at $t=t_3$ to $-V_s$ at $t=t_4$.

So, output voltage across load is V_s .

Now draw the waveform

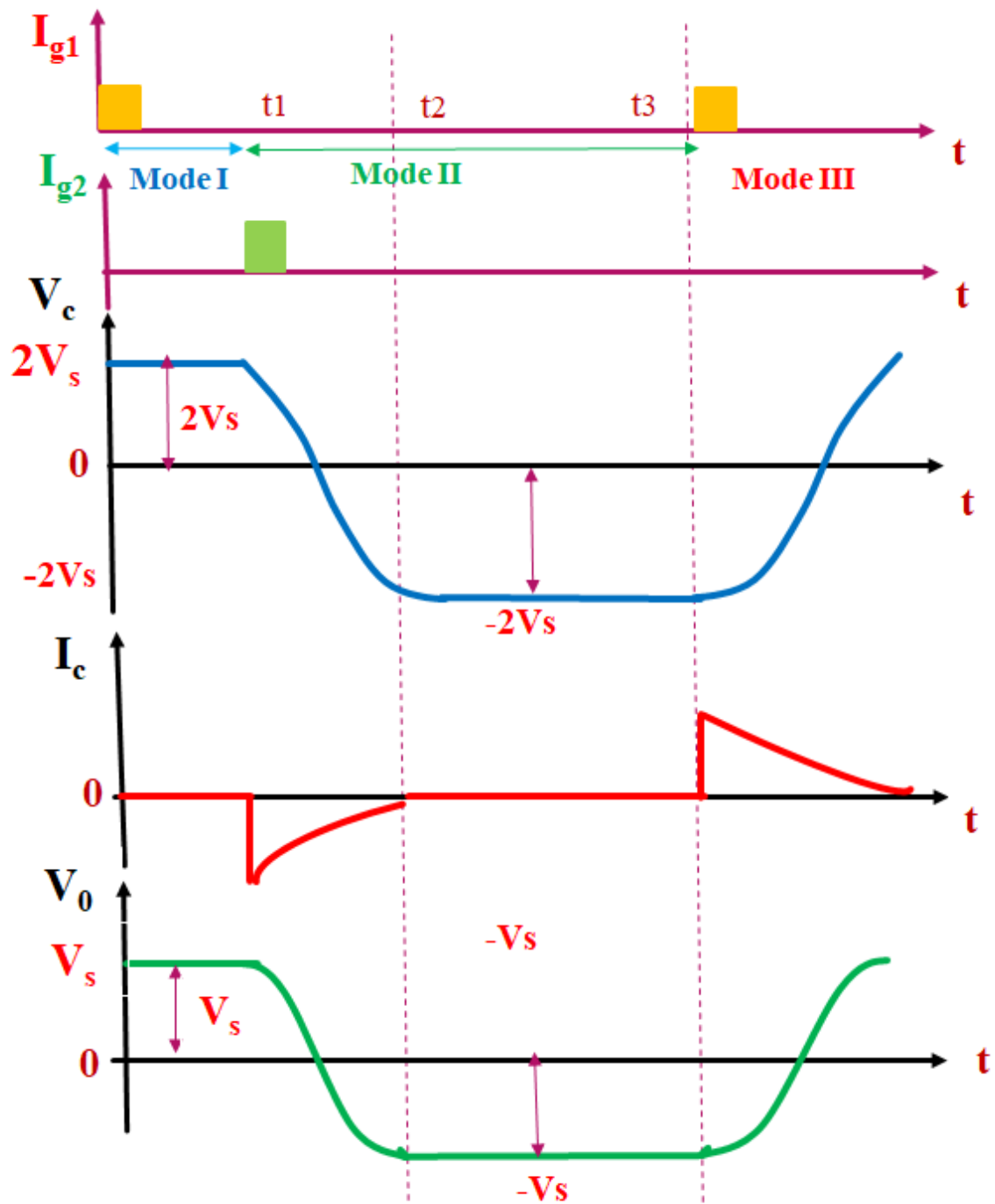

Waveform of parallel Inverter 1) I_{g1} is the gate current given to T1 2) I_{g2} is the gate current given to T2. 3) V_c capacitor voltage 4) I_c current across capacitor 5) V_o output voltage waveform

CYCLOCONVERTER

A **cycloconverter** (also known as a cycloconverter or CCV) converts a constant voltage, constant frequency AC waveform to another AC waveform of a different frequency. A cycloconverter achieves this through synthesizing the output waveform from segments of the AC supply (without an intermediate DC link).

The main forms of electrical energy commonly available are constant DC (Direct Current) and constant AC (Alternating Current). Often though, we need to swap between AC and DC, change the frequency, or swap from constant to variable power. For these conversion purposes, several converters like inverters, rectifiers, DC choppers and **cycloconverters** are employed. The cycloconverters can in fact transfer AC power of a fixed frequency to the AC power of a different frequency (see figure 1).

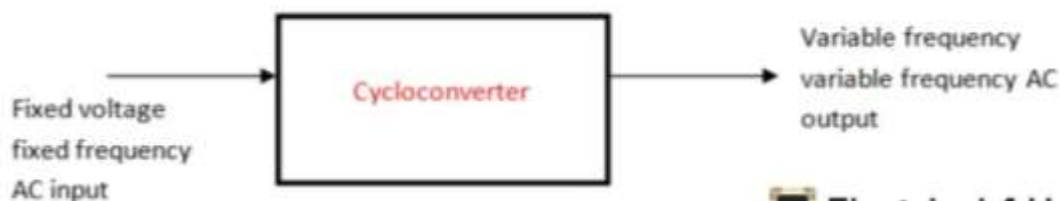

STEP UP CYCLOCONVERTER

Step-up cycloconverter is a single phase to single phase device which converts input AC power at one frequency to output power at a different frequency. The output frequency is more than the input frequency for this cycloconverter. Single phase to single phase means that both the input power and output power are single phase. This article presents the working principle of Step-up Cycloconverter with relevant circuit diagram and waveforms.

Working Principle of Step-up Cycloconverter:

The working principle of a step-up cycloconverter is based on switching of thyristors in a proper sequence. The thyristor acts as a power switch. These switches are arranged in a specific pattern so that the output power is available for both the positive and negative half of the input power supply. ***Forced commutation technique is used to turn OFF the conducting thyristor.***

Two circuit configurations are possible for step-up cycloconverter: ***Mid-point Type and Bridge Type***. In this article, we will consider mid-point type of circuit arrangement for better understanding of working principle.

Circuit Diagram:

Figure below shows the circuit diagram of Mid-point step-up cycloconverter:

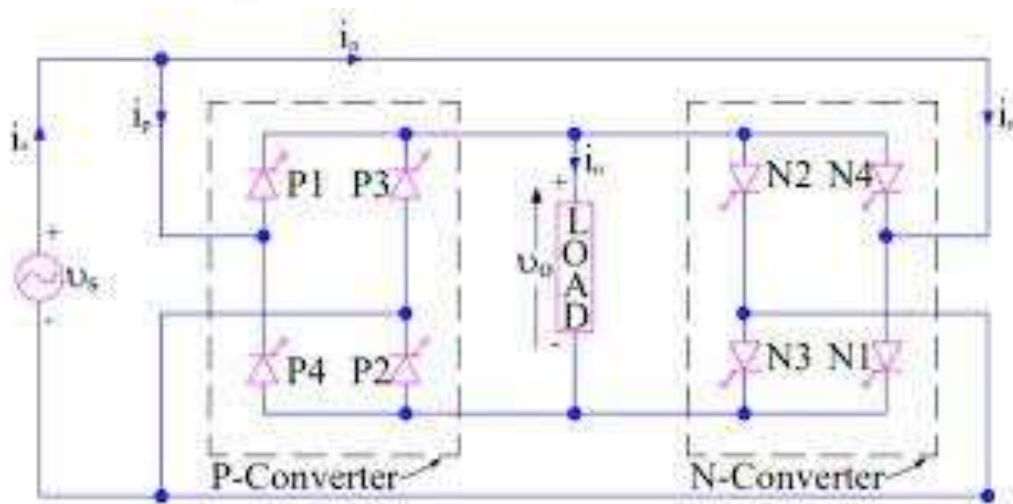
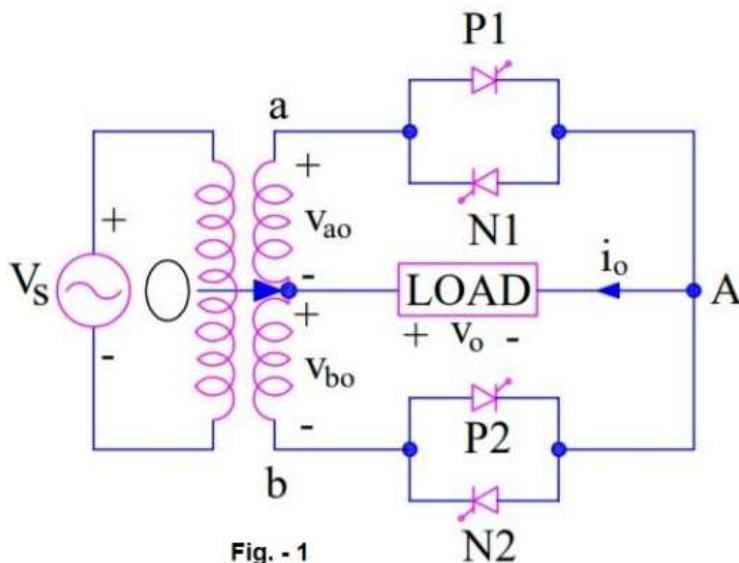

The circuit consists of a single phase transformer with mid tap on the secondary winding and four thyristors. Two of these thyristors P1 & P2 are for positive group. Here positive group means when either P1 or P2 conducts, the load voltage is positive. Other two thyristors N1 & N2 are for negative group. Load is connected between secondary winding mid-point O and terminal A. The load is assumed resistive for simplicity. Assumed positive direction for voltage and current are marked in the circuit diagram.

Operation of Step-up Cycloconverter:

During the positive half cycle of input supply voltage, positive group thyristors P1 & N2 are forward biased for $\omega t = 0$ to $\omega t = \pi$. As such SCR P1 is fired to turn it ON at $\omega t = 0$ such that load voltage is positive with terminal A positive and O negative. The load voltage, thus, follows the positive envelop of the input

supply voltage. At some time instant $\omega t = \omega t_1$, the conducting thyristor P1 is force commutated and the forward biased thyristor N2 is fired to turn it ON. During the period N2 conducts, the load voltage is negative because O is positive & A is negative this time. The load or output voltage traces the negative envelop of the supply voltage. This is shown in figure below.

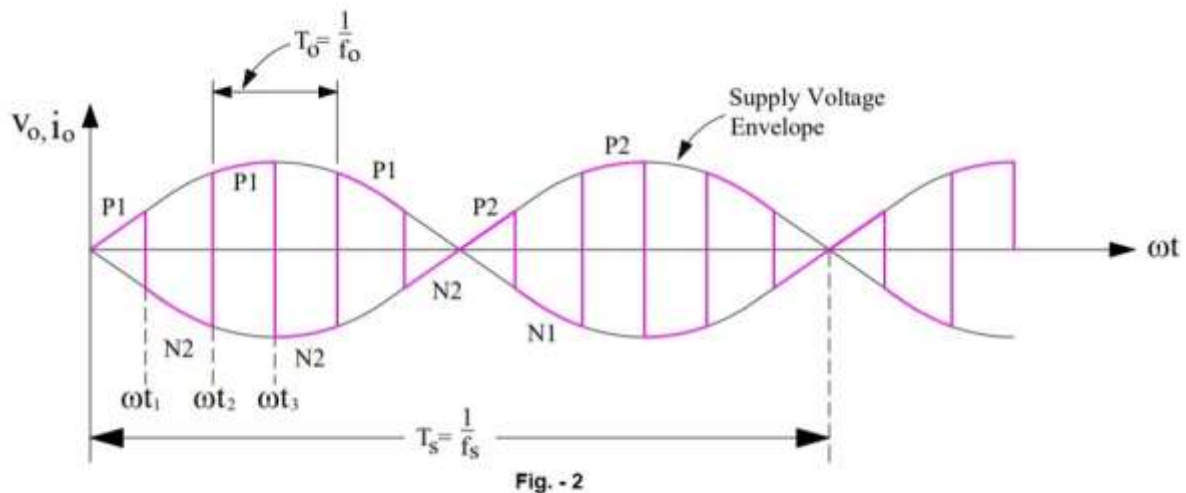

At $\omega t = \omega t_2$, N2 is force commutated and P1 is turned ON. The load voltage is now positive and follows the positive envelop of the supply voltage. At $\omega t = \pi$, terminal “b” is positive with respect to terminal “a”; both SCRs P2 & N1 are therefore forward biased from $\omega t = \pi$ to $\omega t = 2\pi$. AT $\omega t = \pi$, N2 is force commutated and forward biased SCR P2 is turned ON. The load voltage is positive and follows the positive envelop of supply voltage.

If the supply frequency is f_s and output frequency is f_o , P2 will be force commutated at $\omega t = (1/2f_s) + (1/2f_o)$. Carefully note this from the waveform shown in the figure-2.

When P2 is force commutated, forward biased SCR N1 is turned ON. This time, the load voltage is negative and follows the negative envelop of the supply input.

In this manner, SCRs P1, N2 for the first half cycle; P2, N1 in the second half cycle and so on are switched alternately between positive and negative envelopes at a high frequency. This results in output frequency f_o more than the input supply frequency f_s . In our example of figure-2, note that there is a total of 6 cycles of output in one cycle of input supply. This means that frequency of output voltage is 6 times of input frequency i.e. $f_o = 6f_s$.

STEP DOWN CYCLOCONVERTER

Step-down cycloconverter is a device which steps down the fixed frequency power supply input into some lower frequency. It is a frequency changer. If f_s & f_o are the supply and output frequency, then $f_o < f_s$ for this cycloconverter.

The most important feature of step-down cycloconverter is that it does not require force commutation. Line or Natural Commutation is used which is provided by the input AC supply.

Circuit Diagram:

There are two circuit configurations of a step-down cycloconverter: **Mid-point and Bridge type**. This article, focuses on the mid-point type. The operation for continuous and discontinuous type of RL load is explained for mid-point type cycloconverter.

Figure below shows the circuit diagram of mid-point type cycloconverter. The positive direction of voltage and current are marked in the diagram.

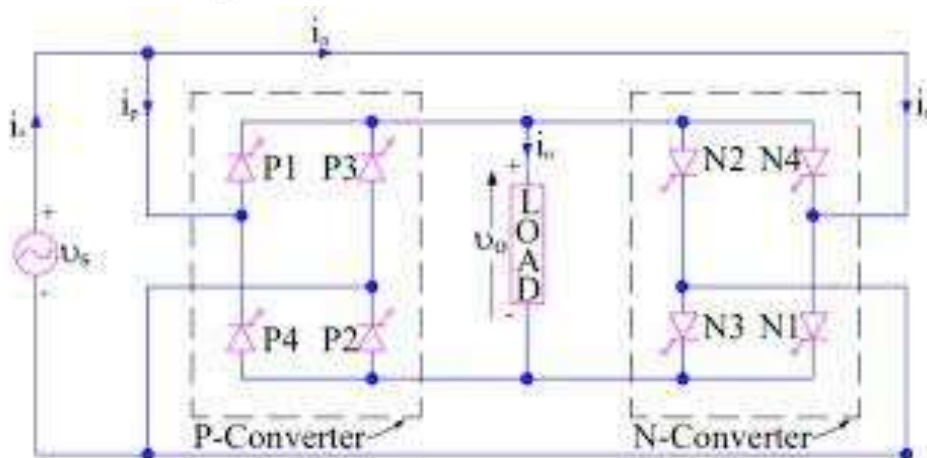
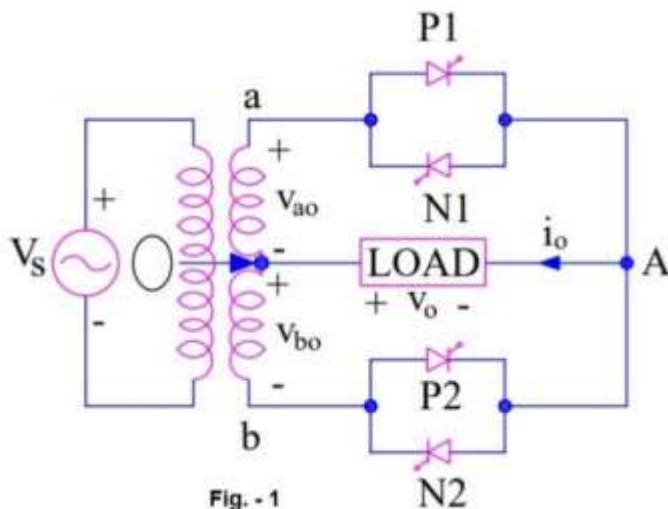

The working principle of step-down cycloconverter is explained for discontinuous and continuous load current. The load is assumed to be comprised of resistance (R) & inductance (L).

Discontinuous Load Current:

For positive cycle of input AC supply, the terminal A is positive with respect to point O. This makes SCRs P1 forward biased. The forward biased SCR P1 is triggered at $\omega t = 0$. With this, load current i_o starts building up in the positive direction from A to O. Load current i_o becomes zero at $\omega t = \beta > \pi$ but less than $(\pi + \alpha)$. Refer figure-2. The thyristor P1 is thus, naturally commutated at $\omega t = \beta$ which is already reversed biased after π .

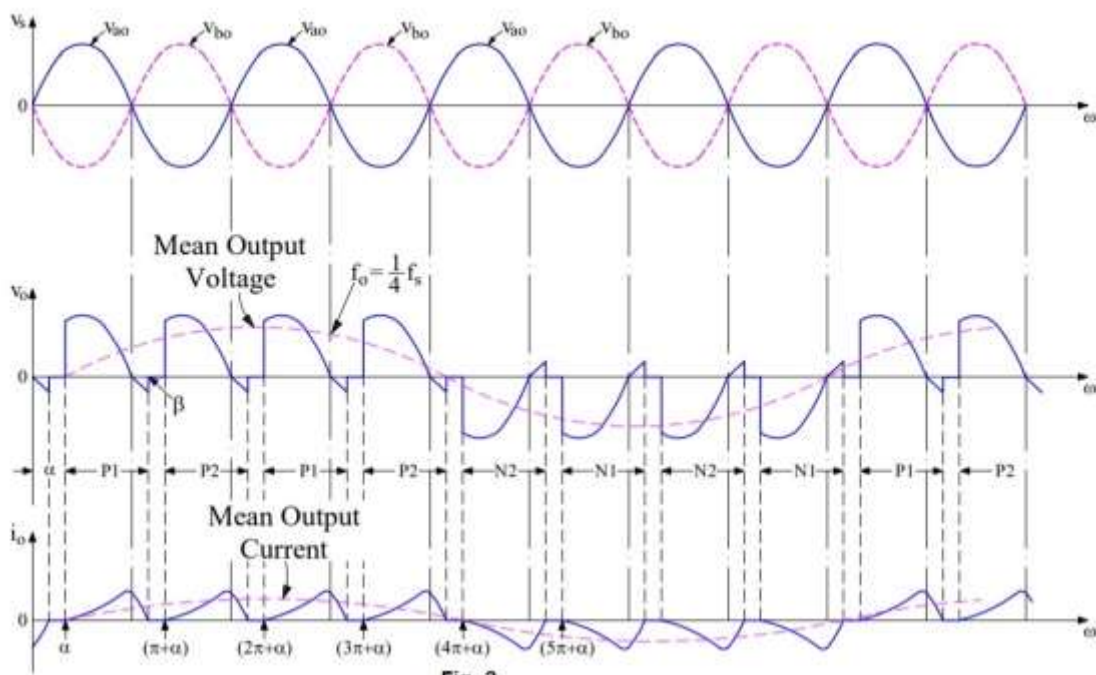

Fig.-2

After half a cycle, b is positive with respect to O. Now forward biased thyristor P2 is fired at $\omega t = (\pi + \alpha)$. Load current is again positive from A to O and builds up from zero as shown in figure-2. At $\omega t = (\pi + \beta)$, i_o decays to zero and P2 is naturally commutated. At $\omega t = (2\pi + \alpha)$, P is again turned ON. Load current in figure-2 is seen to be discontinuous.

After four positive half cycles of load voltage and load current, thyristor N2 is gated at $(4\pi + \alpha)$ when O is positive with respect to b. As N2 is forward biased, it starts conducting but the direction of load current is reverse this time i.e. it flows from O to A. After N2 is triggered, O is positive with respect to "a" but before N1 is fired, i_o decays to zero and N2 is naturally commutated. Now when N1 is gated at $(5\pi + \alpha)$, i_o again builds up but it decays to zero before thyristor N2 in sequence is again gated.

In this manner, four negative half cycles of load voltage and load current, equal to number of positive half cycles of load voltage & current, are generated. Now P1 is again triggered to fabricate four positive half cycles of load voltage and so

on. It may be noted that, natural commutation is achieved for discontinuous current load.

From figure-2, the waveform of mean load voltage & current may be noted. It is clear that the output frequency of load voltage & current is $(\frac{1}{4})$ times of input supply frequency.

Continuous Load Current:

When “a” is positive with respect to O in figure-1, P1 is triggered at $\omega t = \alpha$, positive output voltage appears across load and load current starts building up as shown in figure-3. At $\omega t = \pi$, supply and load voltages are zero. After $\omega t = \pi$, P1 is reversed biased. As load current is continuous, P1 is not turned OFF at $\omega t = \pi$. When P2 is triggered in sequence at $(\pi + \alpha)$, a reverse voltage appears across P1, it is therefore turned OFF by natural commutation.

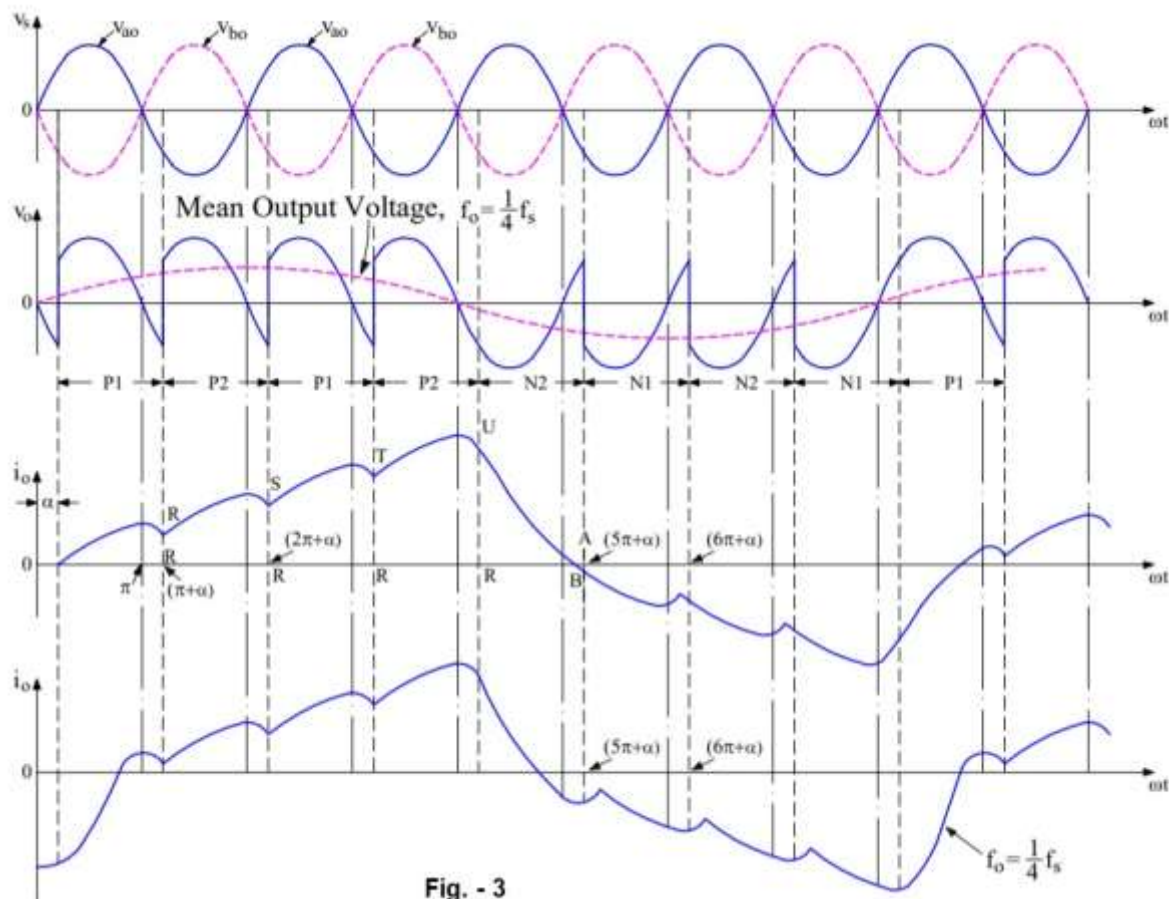

Fig. - 3

When P1 is commutated, load current has builds up to a value equal to RR. With the tun ON of P2 at $(\pi + \alpha)$, output voltage is again positive. As a consequence, load current builds up further than RR as shown in figure-3. At $(2\pi + \alpha)$, when P1 is again turned ON, P2 is naturally commutated and load current through P1 builds up beyond RS.

At the end of four positive half cycles of output voltage, load current is RU. When N2 is triggered after P2, load is subjected to negative voltage cycle and load

current i_o decreases from RU to negative AB. Now N2 is commutated and N1 is gated at $(5\pi+\alpha)$. Load current i_o becomes more negative than AB at $(6\pi+\alpha)$, this is because with N1 ON, load voltage is negative. For four negative half cycles of output voltage, current i_o is shown in figure-3. Load current waveform is redrawn in the last waveform of figure-3.

It may be seen from the waveform of load current that it is symmetric with respect to wt axis. The mean waveform of load voltage is also shown in load voltage waveform. It is clear from the load current and mean load voltage waveform that the output frequency is one fourth of the input supply frequency i.e. $f_o = (1/4)f_s$.

MODULE-4

4.1 Application of Power Electronics

Below is an attempt to briefly present the diaspora of power electronics.

application of power electronics

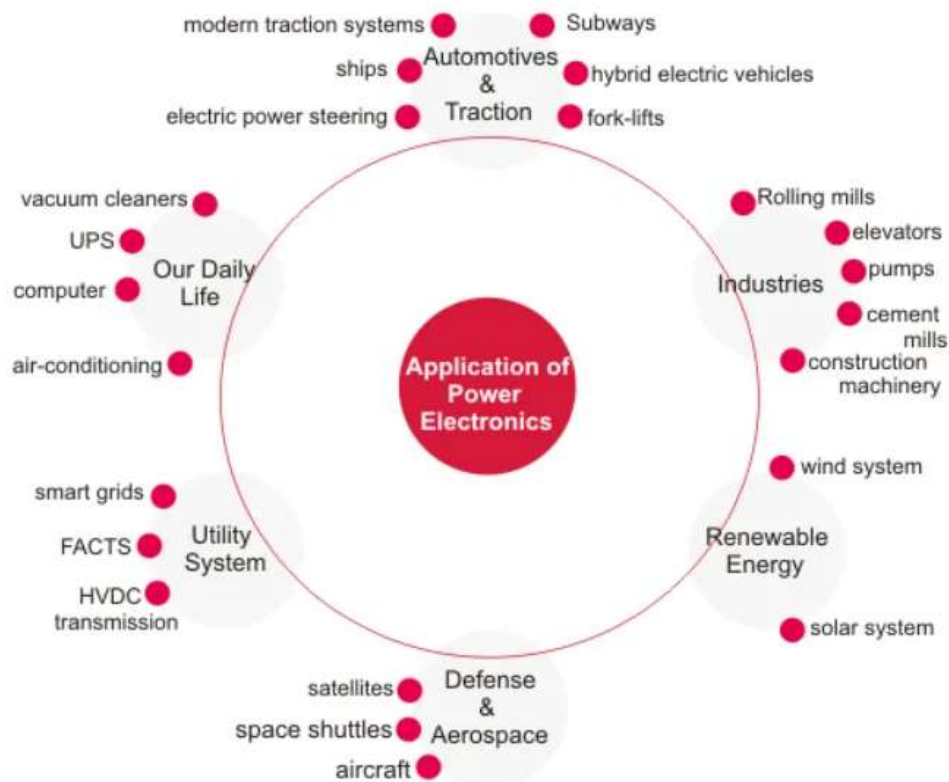

Our Daily Life: If we look around ourselves, we can find a whole lot of power electronics applications such as a fan regulator, light dimmer, air-conditioning, induction cooking, emergency lights, personal computers, vacuum cleaners, UPS (uninterrupted power system), battery charges, etc.

Automotive and Traction: Subways, hybrid electric vehicles, trolley, fork-lifts, and many more. A modern car itself has so many components where power electronic is used such as ignition switch, windshield wiper control, adaptive front lighting, interior lighting, electric power steering and so on. Besides power electronics are extensively used in modern traction systems and ships.

Industries: Almost all the motors employed in the industries are controlled by power electronic drives, for eg. Rolling mills, textile mills, cement mills, compressors, pumps, fans, blowers, elevators, rotary kilns etc. Other applications include welding, arc furnace, cranes, heating applications, emergency power systems, construction machinery, excavators etc.

Défense and Aerospace: Power supplies in aircraft, satellites, space shuttles, advance control in missiles, unmanned vehicles and other defense equipments.

Renewable Energy: Generation systems such as solar, wind etc. needs power conditioning systems, storage systems and conversion systems in order to become usable. For example solar cells generate DC power and for general application we need AC power and hence power electronic converter is used.

Utility System: HVDC transmission, VAR compensation (SVC), static circuit breakers, generator excitation systems, FACTS, smart grids, etc.

4.2 Factors Affecting the Speed of D.C. Motor

According to the speed equation of a d.c. motor we can write,

$$N \propto \frac{E_b}{\phi} \propto \frac{V - I_a R_a}{\phi}$$

The factors Z, P, A are constants for a d.c. motor.

But as the value of armature resistance R_a and series field resistance R_{se} is very small, the drop $I_a R_a$ and $(R_a + R_{se})$ is very small compared to applied voltage V . Hence neglecting these voltage drops the speed equation can be modified as,

$$N \propto \frac{V}{\phi} \quad \text{as } E_b = V$$

Thus, the factors affecting the speed of a d.c. motor are,

1. The flux Φ
2. The voltage across the armature
3. The applied voltage V

depending upon these factors the various methods of speed control are,

1. Changing the flux Φ by controlling the current through the field winding called flux control methods.
2. Changing the armature path resistance which in turn changes the voltage applied across the armature called rheostatic control.
3. Changing the applied voltage called voltage control method.

4.3 DC Motor speed Control through Converters:

DC motor control is conveniently and efficiently achieved by phase-controlled converters wherein the ac input voltage is converted to a controlled dc output. The commutation process, the transfer of current from one thyristor to the other, in these converters is the inexpensive **natural** or **line commutation**. As, an incoming thyristor is turned-on, it reverse-biases the outgoing thyristor, turning it off. No additional commutation circuitry is therefore required. The power conversion efficiency in these converters is above 95% because of relatively low losses in thyristors. These converters are used in the speed control of fractional-kW dc motors as well as in large motors employed in variable-speed reversing drives for rolling mills with motor ratings as large as several MWs.

In certain types of converters (**semi-converters**) a diode known as a, **free-wheeling diode** is connected across motor terminals to allow for dissipation of energy stored in motor inductance and to provide for continuity of motor current when the thyristors are blocked. It also provides protection against transient overvoltage.

Single Phase Half Wave Converter:

Figure 11.14 shows a single-phase half-wave converter for controlling a separately excited DC Motor. It requires a single thyristor and a free-wheeling diode. In this circuit the motor current is always discontinuous, resulting in poor motor performance. This type of converter is employed only for motors below 400 W. It will not be described in detail here; these easily follow from the description of waveforms (voltage and current) for the semi-converter.

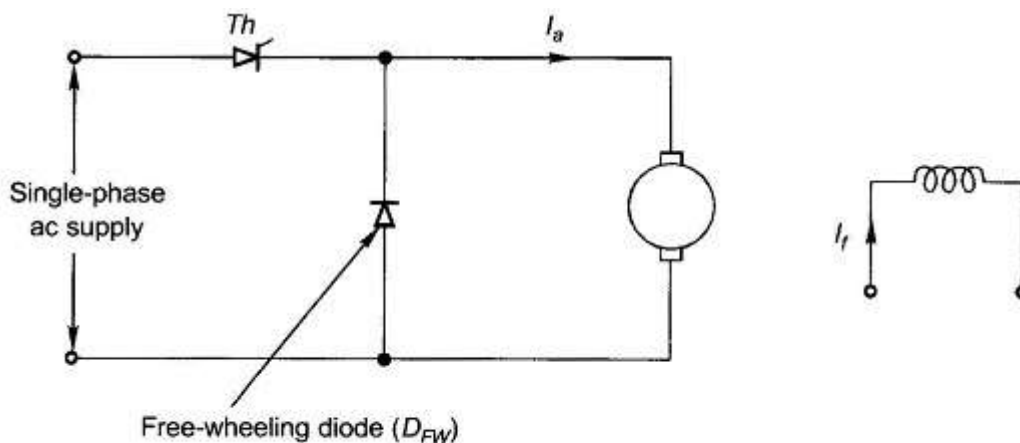

Fig. 11.14 Single-phase, half-wave converter

Semi-Converter feeding a Separately excited DC Motor:

This is a one-quadrant converter (Fig. 11.15a) which gives voltage and current of one polarity at dc terminals. It therefore does not provide for regenerative braking, i.e. power flow from DC Motor Control to the ac supply. Where regeneration is not required, this converter is used for reasons for economy.

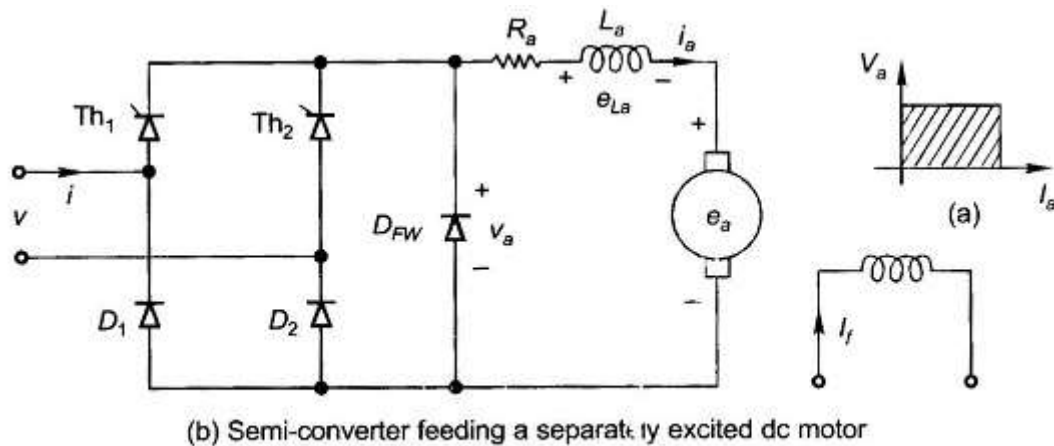

Fig 11.15

Figure 11.15(b) gives the circuitry of a semi-converter feeding a separately excited DC Motor Control. The armature resistance R_a and inductance L_a are shown lumped in series with an armature-induced emf e_a while the armature terminal voltage is v_a . It has two thyristors, two diodes and a free-wheeling diode (connected across motor terminals). It will be assumed that in steady-state operation the armature current is continuous over the whole range of operation. Typical steady-state voltage and current waveforms are shown in Fig. 11.16. The thyristor Th_1 is fired at angle α and Th_2 at angle $\pi + \alpha$ with respect to the supply voltage v and the process is repeated continuously.

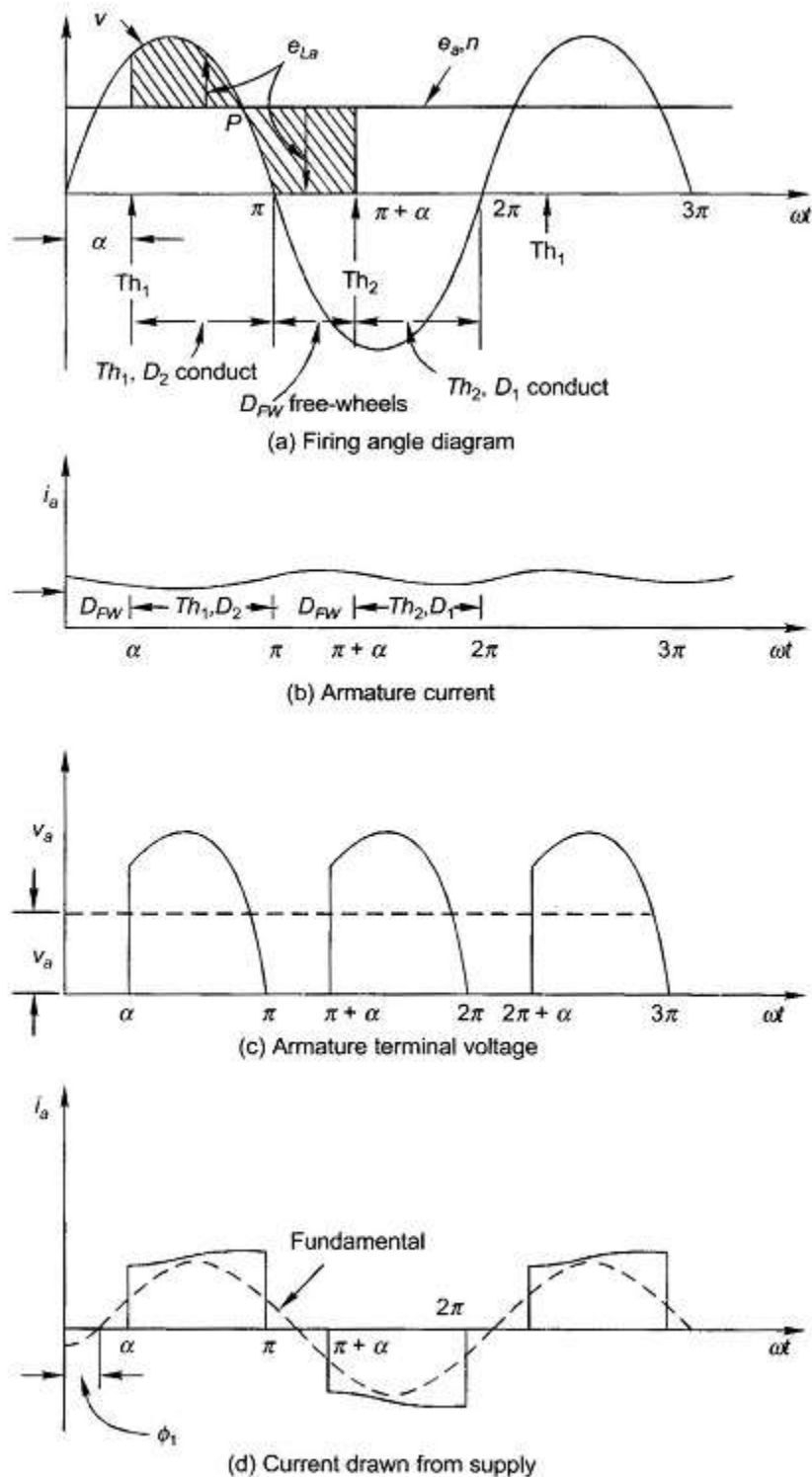

Fig. 11.16 Voltage and current waveforms of semiconverter feeding separately excited dc motor; continuous armature current

Under steady conditions, as Th_1 is fired ($\omega t = \alpha$), Th_1 and D_2 conduct and the motor is connected to the supply, i.e. $v_a = v$. At $\omega t = \pi$, v_a tends to become negative as the input voltage polarity changes. This causes D_{FW} , the free-wheeling diode, to become forward-biased and the armature current flowing through Th_1D_2 is transferred to D_{FW} , which means that Th_1 commutates (naturally). The

motor terminals are shorted through D_{FW} for the free-wheeling period $\pi < \omega t < \pi + \alpha$ providing for continuity of the armature current during this period when the motor remains disconnected from the supply. At $\omega t = \pi + \alpha$, Th_2 is fired and Th_2D_1 conduct, causing D_{FW} to become reverse-biased and therefore open-circuited. The motor is once again connected positively to the supply for the next period of $\pi + \alpha < \omega t < 2\pi$. This process repeats continuously.

Various voltage and current waveforms of a separately excited DC Motor Control fed through a semi-converter are shown in Fig. 11.16. Though the voltage across motor terminals (Fig. 11.16(c)) contains harmonics over and above a steady dc value, it is rightly assumed here that the motor does not respond to these harmonics and therefore runs at constant speed (n) and has constant induced emf (e_a). As Th_1 fires at $\omega t = \alpha$, the motor current is given by

$$\frac{1}{L_a} \int_{\alpha}^{\omega t} (v - e_a) d(\omega t); \text{ assuming } R_a \text{ negligible} \quad (11.1)$$

up to the point P shown in Fig. 11.16(a); $v > e_a$ so that the motor current increases. So does the motor emf e_a . During this period, apart from the energy being delivered to the load, energy is also being stored in motor inductance (L_a). Beyond the point P, $v < e_a$ and the motor current begins to decrease. This also implies the reversal of voltage across the motor inductance which now feeds energy into the system. During the free-wheeling period ($\pi < \omega t < \pi + \alpha$), the diode continues to be forward-biased by the reversal of the inductive voltage. During this period a part of the energy stored in motor inductance is consumed to feed the mechanical load. The motor current, speed and emf, therefore, all reduce. This process then repeats over the next period ($\pi + \alpha < \omega t < 2\pi + \alpha$) via Th_2D_1 and later through D_{FW} . The current drawn from the supply shown in Fig. 11.16(d) is that part of the armature current which flows over the periods (α, π) , $(\pi + \alpha, 2\pi)$, ... when the motor is connected to the supply. It is not necessary to use the free-wheeling diode. In its absence at $\omega t = \pi$, D_1 becomes forward-biased so that free-wheeling takes place through Th_1D_1 till Th_2 is fired. At $\omega t = 2\pi$ free-wheeling takes place through Th_2D_2 and so on.

It should be observed from Fig. 11.16(d) that the fundamental of the current drawn from the mains lags the voltage by an angle $\Phi_1 (< \alpha)$.

Discontinuous Armature Current:

The armature current becomes discontinuous for large values of the firing angle, high speed and low values of torque. The motor performance deteriorates with discontinuous armature current. The ratio of peak to average and rms to average armature current increases. It is, therefore, desirable to operate the motor in the continuous current mode. To achieve this, an external armature circuit choke may be used, which decreases the rate of current decay during the free-wheeling operation.

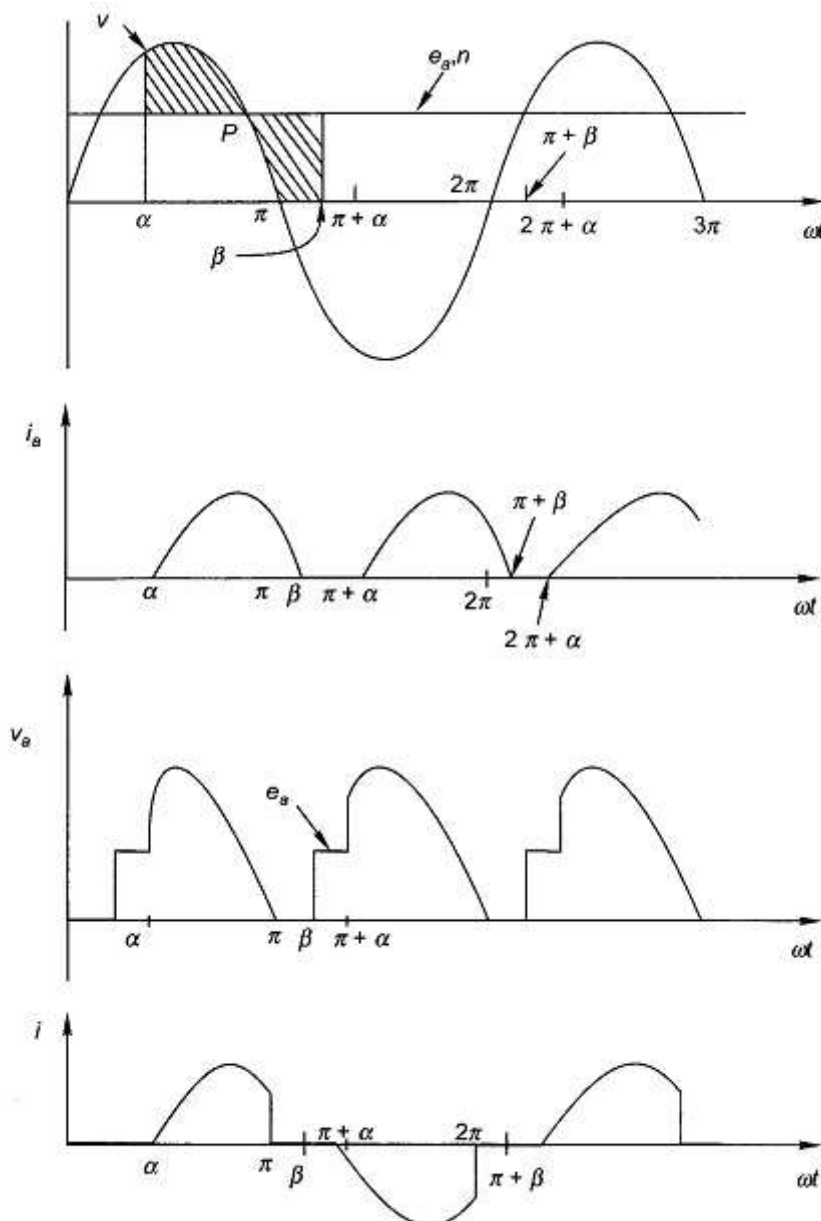

Fig. 11.17 Voltage and current waveforms of semiconverter feeding separately excited dc motor; discontinuous armature current

The voltage and current waveforms for semi-converter with discontinuous current are shown in Fig. 11.17. The motor is connected to supply through Th_1D_2 for the period $\alpha < \omega t < \pi$. Beyond π , the motor is shorted through the free-wheeling diode D_{FW} . The armature current decays to zero at angle β (extinction angle) $\pi + \alpha$, i.e., before the thyristor Th_2 is fired, thereby making the armature current discontinuous. During α to π , the conduction period through Th_1D_2 , the motor terminal voltage is the same as the input voltage. During π to β the motor terminal voltage is zero as motor terminals are shorted by the free-wheeling diode. From β to $\pi + \alpha$, the motor coasts and so its terminal voltage is the same as its induced emf.

Full-Converter feeding a Separately Excited DC Motor:

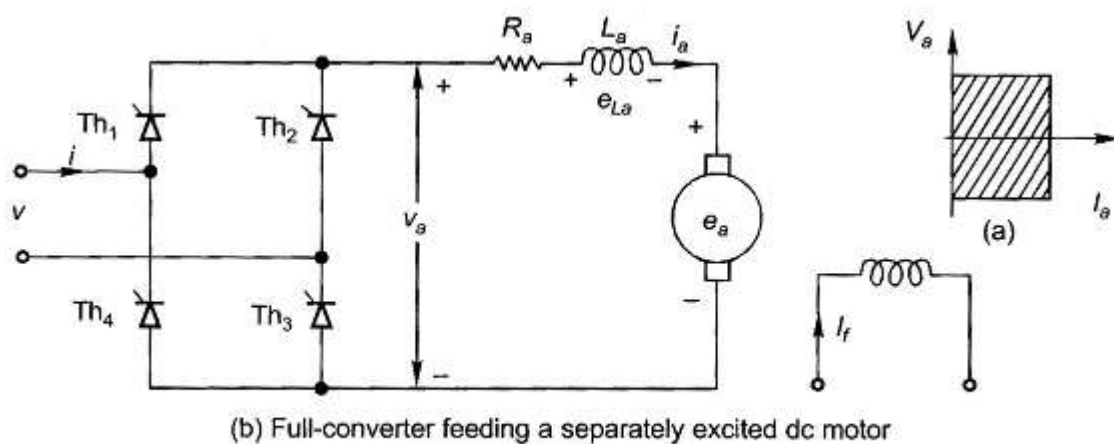

Fig. 11.18

A full-converter is a two-quadrant converter (see Fig. 11.18(a)) in which the voltage polarity of the output can reverse, but the current remains unidirectional because of the unidirectional thyristors. A full-converter employs four thyristors but no free-wheeling diode is required. A full-converter feeding a separately excited DC Motor Control is shown in Fig. 11.18. The voltage and current waveforms are shown in Fig. 11.19 with the assumption that the armature current i_a is almost constant. Thyristors $Th_1 Th_3$ conduct for the interval $\alpha < \omega t < \pi + \alpha$ and connect the motor to supply. At $\pi + \alpha$, thyristors Th_2Th_4 are triggered. Immediately the supply voltage appears in reverse-bias across $Th_1 Th_3$ and turns them off. This is **natural** or **line commutation**. The motor current is transferred from $Th_1 Th_3$ to Th_2Th_4 . Since there is no period when the motor is disconnected from supply, no free-wheeling is necessary. During α to π , energy flows from the supply to motor (both v and i are positive and so are v_a and i_a).

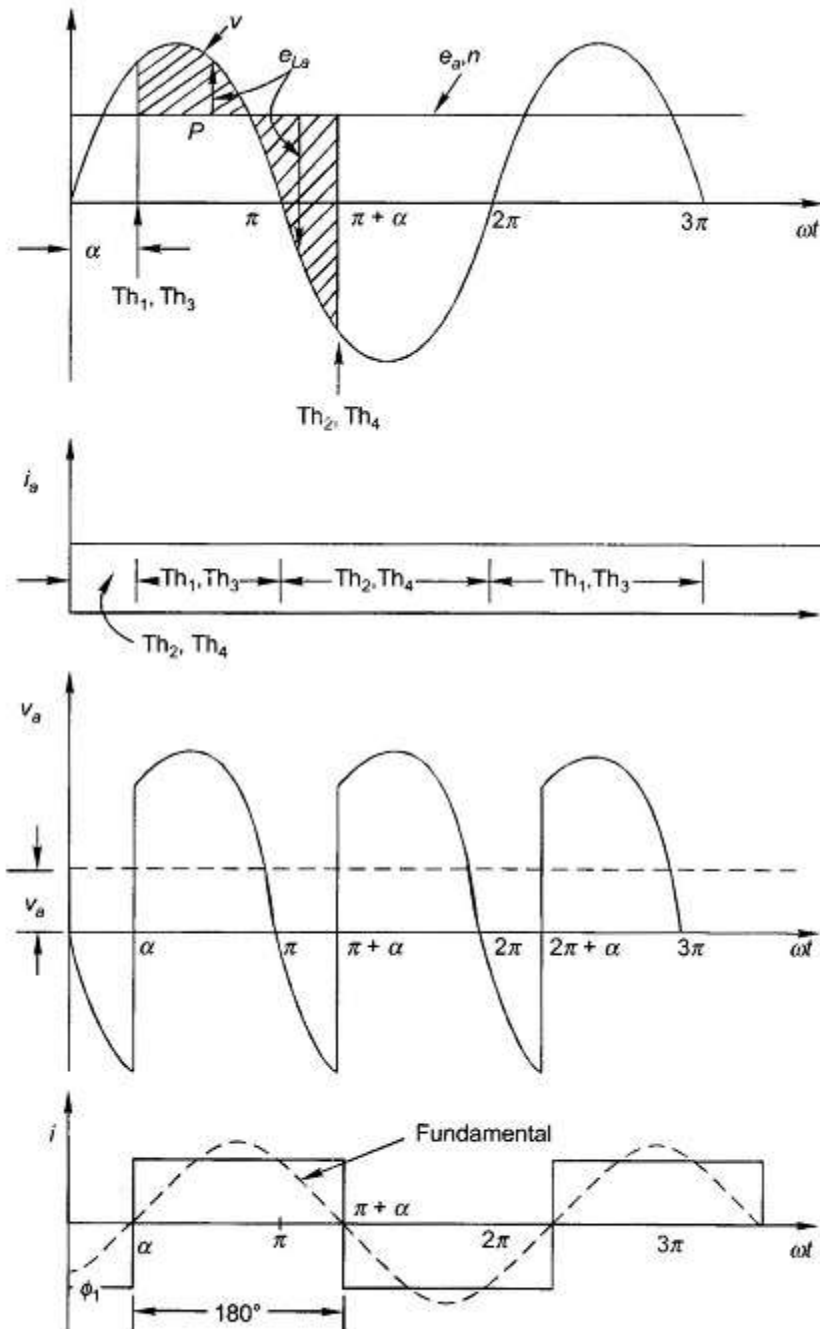

Fig 11.19 Voltage and current waveforms of full-converter feeding separately excited dc motor, continuous armature current (almost constant); $\alpha < 90^\circ$

However, during π to $\pi + \alpha$, some of the motor energy is fed back to the supply (v and i have opposite polarity and so are v_a and i_a which means reversal of power flow). Observe that the fundamental of the current drawn from the mains lags the voltage by angle $\Phi_1 = \alpha$.

The voltage and current waveforms for $\alpha > 90^\circ$ are shown in Fig. 11.20. The average motor terminal voltage is now negative. If the motor terminals are reversed, it will act as a generator feeding power back to the ac supply. This is the **inversion operation** of the converter and is used in regenerative braking of

the motor. One point needs to be noted here. During the conduction period of either Th_1Th_3 or Th_2Th_4 as the supply voltage becomes negative, the armature current begins to reduce, causing the inductance polarity to reverse so that the conducting thyristors continue to be forward-biased.

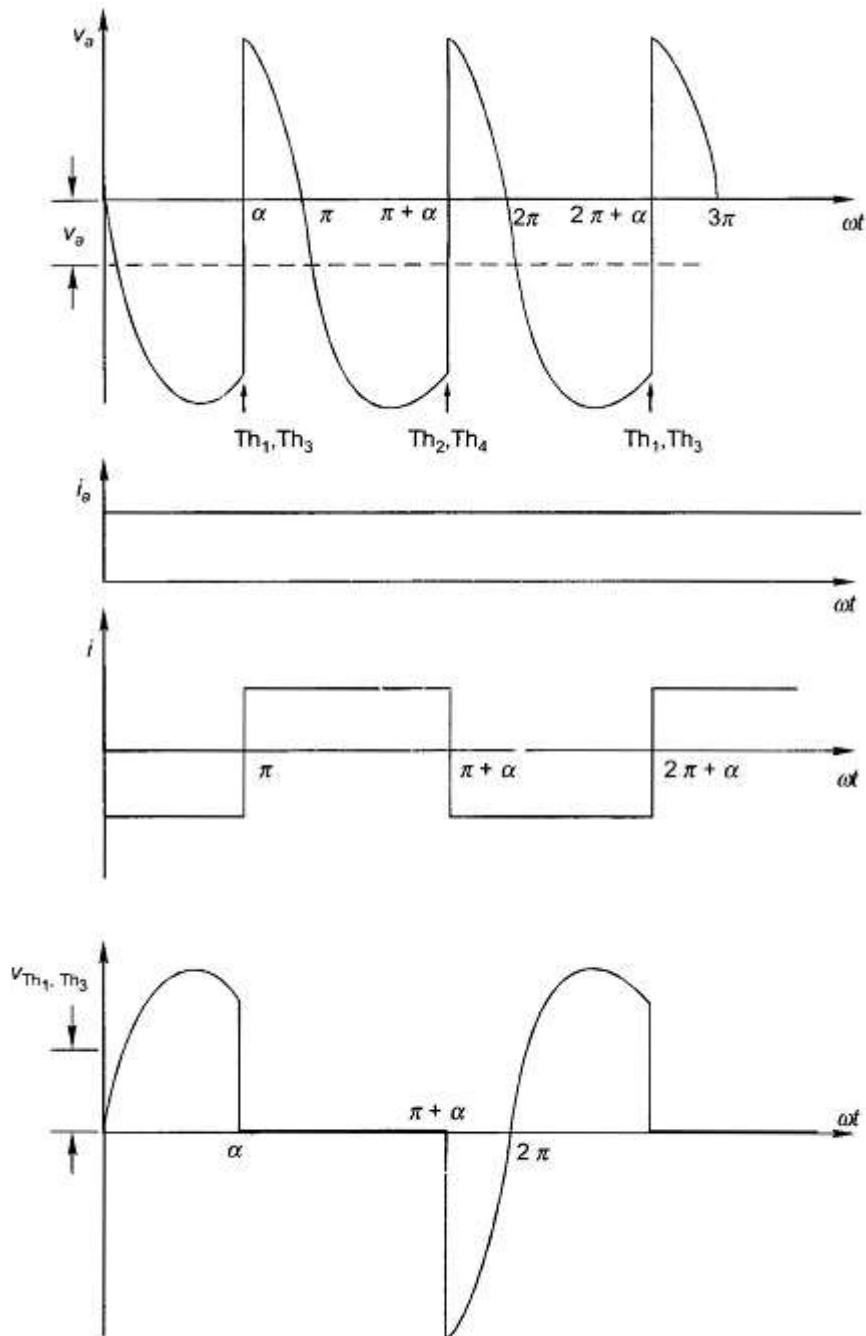

Fig. 11.20 Voltage and current waveforms for full converter; $\alpha > 90^\circ$

The voltage and current waveforms for the case of discontinuous armature current can be found as in the case of the semi-converter. (see Fig. 11.20).

Torque-Speed Characteristics:

It will be assumed here that the armature current is continuous. For a semi-converter with free-wheeling diode action, the armature circuit equations are

$$v_a = v = R_a i_a + L_a \frac{di_a}{dt} + e_a \quad \alpha < \omega t < \pi \quad (11.2)$$

$$v_a = 0 = R_a i_a + L_a \frac{di_a}{dt} + e_a \quad \pi < \omega t < \pi + \alpha \quad (11.3)$$

For a full-converter, the armature circuit equation is

$$v_a = v = R_a i_a + L_a \frac{di_a}{dt} + e_a \quad \alpha < \omega t < \pi + \alpha \quad (11.4)$$

Let $v = \sqrt{2} V \sin \omega t$. The average motor terminal voltages are: With a semi-converter,

$$V_a = \frac{1}{\pi} \int_{\alpha}^{\pi} \sqrt{2} V \sin \omega t d(\omega t) = \frac{\sqrt{2} V}{\pi} (1 + \cos \alpha) \quad (11.5)$$

With a full-converter,

$$V_a = \frac{1}{\pi} \int_{\alpha}^{\pi + \alpha} \sqrt{2} V \sin \omega t d(\omega t) = \frac{2\sqrt{2} V}{\pi} \cos \alpha \quad (11.6)$$

Figure 11.21 gives the variation of the motor terminal voltage as a function of the firing angle for both the semi-converter and full-converter. In the case of the full-converter inversion operation occurs for $90^\circ < \alpha < 180^\circ$.

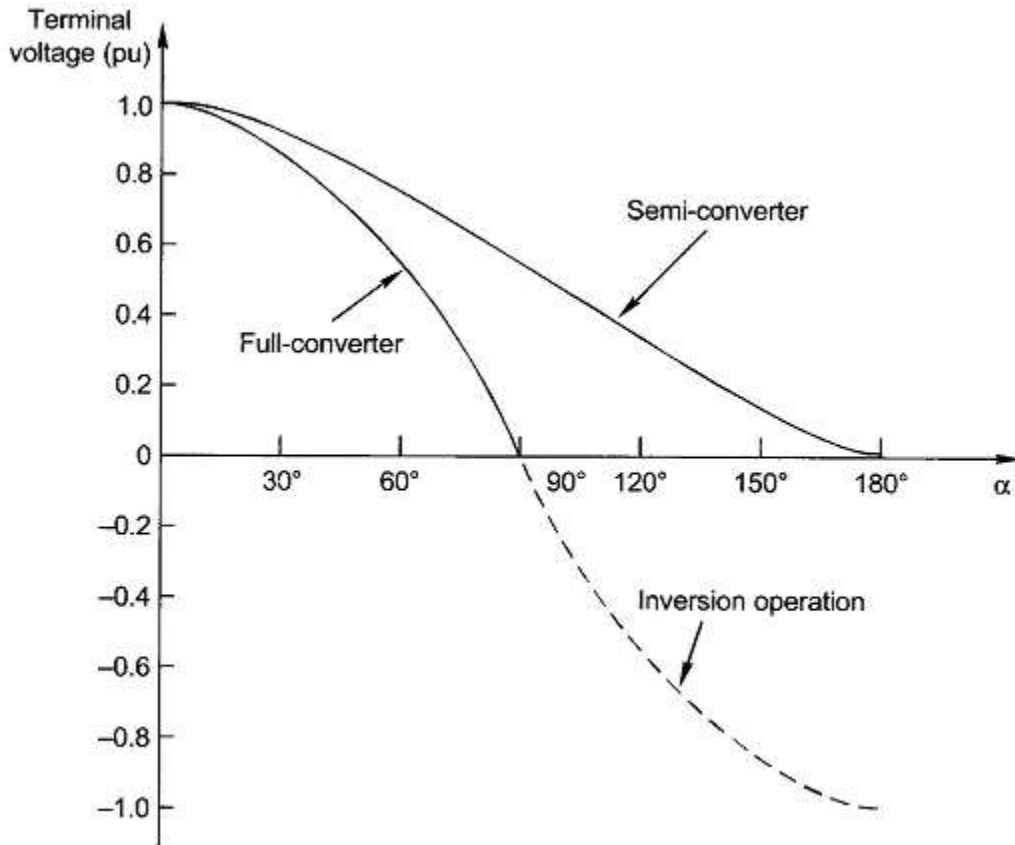

Fig. 11.21 Variation of the converter terminal voltage with firing angle

The motor equations for average values are

$$E_a = K_a \Phi n \quad (11.7)$$

$$T = K_a \Phi I_a \quad (11.8)$$

and

$$n = \frac{V_a - I_a R_a}{K_a \Phi} \quad (11.9)$$

Substituting for I_a from Eq. (11.8) and V_a from Eqs (11.5) or (11.6) in Eq. (11.9), the speed-torque characteristics are given as follows:

With a semi-converter,

$$n = \frac{(\sqrt{2}V/\pi)(1 + \cos \alpha)}{K_a \Phi} - \frac{R_a}{(K_a \Phi)^2} T \quad (11.10)$$

With a full-converter

$$n = \frac{2\sqrt{2}V \cos \alpha}{K_a \Phi} - \frac{R_a}{(K_a \Phi)^2} T \quad (11.11)$$

The first term in Eqs. (11.10) and (11.11) represents the theoretical no-load speed while the second term represents speed drop caused by armature resistance. The theoretical no-load speed can be varied by the firing angle α .

In the case of discontinuous current, the average voltage at motor terminals depends upon the angle β (extinction angle) which itself is dependent on the average motor speed n , average motor current I_a and firing angle α . The analytical treatment of this case is beyond the scope of this book.

Dual-Converter:

The dual-converter can operate in all the four quadrants as shown in Fig. 11.22(a). Its circuit is shown in Fig. 11.22(b). It is indeed two full-converters converting to dc in either direction. The dual converter provides virtually instantaneous reversal of voltage at dc terminals.

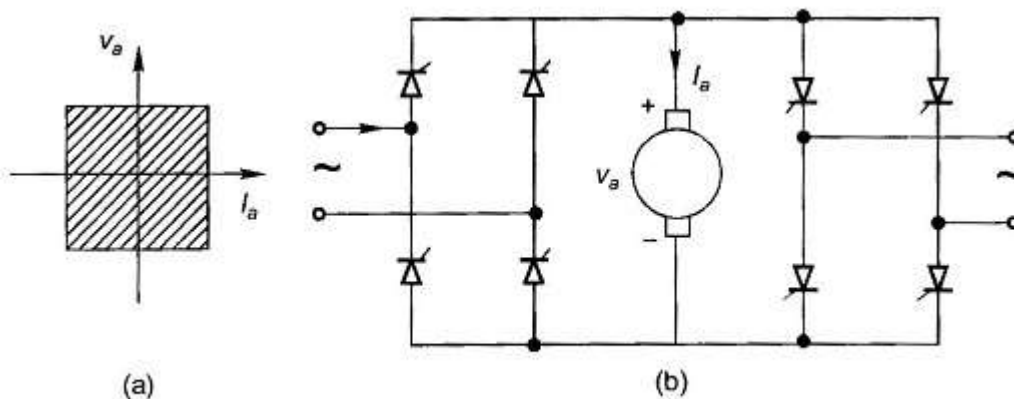

Fig. 11.22

Control of DC Series Motor:

Semi-converters and full-converters are also employed for control of a dc series motor. The total circuit inductance is high because of the series field, as a consequence of which the armature current is mostly continuous. The governing motor equations differ as the flux/pole is now proportional to the armature current. The treatment otherwise is similar to that of a separately excited DC Motor Control and will not be pursued here for want of space.

4.4 DC Motor Speed Control using Chopper

In many different applications it is required to control speed of DC motor. Some of the examples are

- In treadmill machine it is required to vary the speed of motor that used to roll the belt
- The speed of DC motor used in railway engines (traction) has to be varied
- E-bikes, e-bicycles, e-scooters also runs on DC motor and to vary their speed it is required to control speed of DC motor
- DC motors are also used in portable sewing machine, drill machine etc, in which speed control of motor is provided for different operation

One of the popular methods of speed control of DC motor is using chopper. *Chopper is a device that gives variable DC output from applied fixed DC input.* It simply chops fixed DC and generates variable DC. Let us first understand how it generates variable DC.

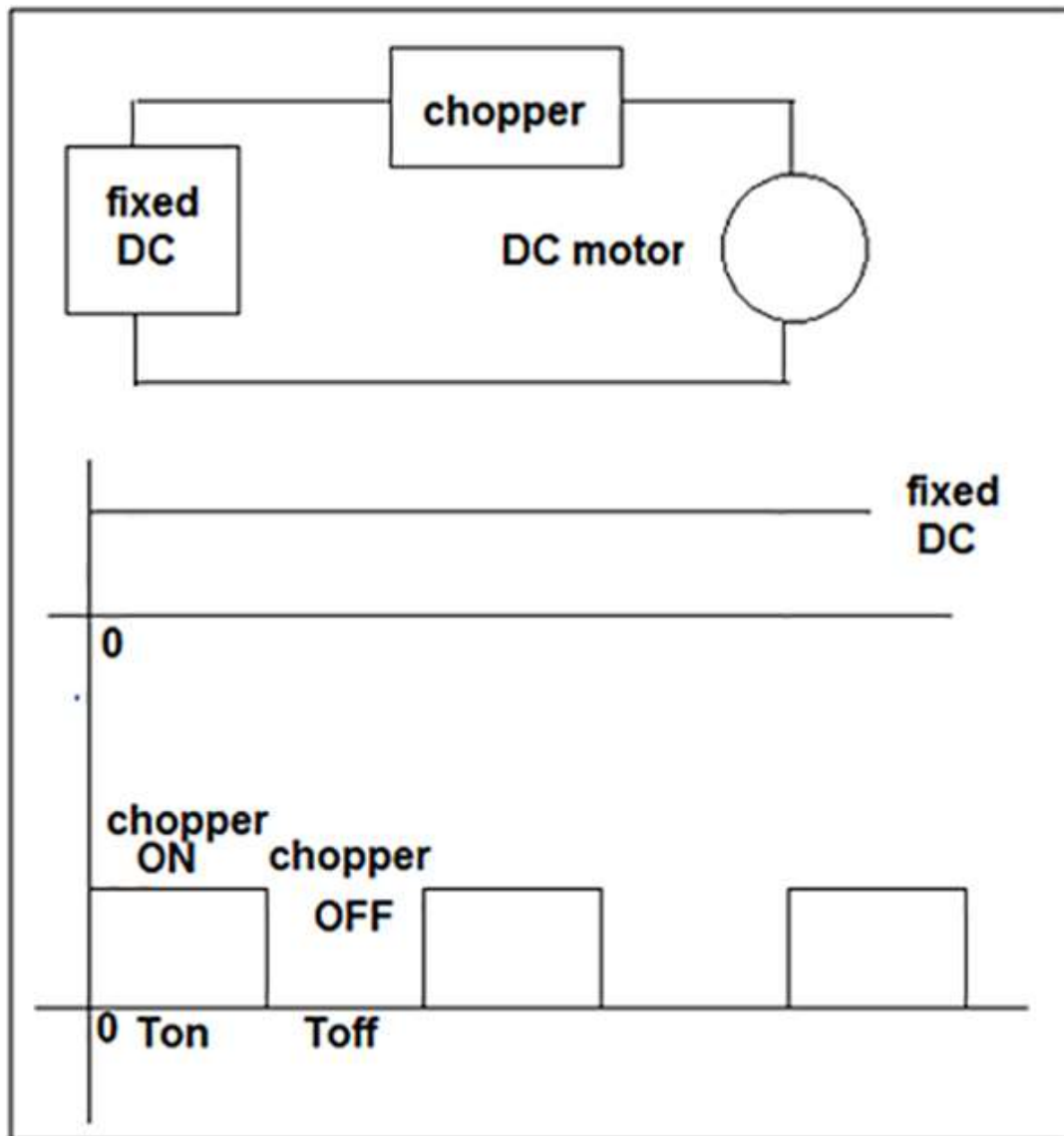

Fig. 1: Block Representation of Chopper circuit used to control rotation of DC Motor

As shown in figure the chopper supplies fixed DC voltage to motor. When chopper is ON motor gets supply but when chopper is off motor does not get the supply. So as shown in figure let us say chopper is on for T_{on} time and it is off for T_{off} time. So depending upon the T_{on} and T_{off} time the DC voltage applied to motor is

$$V_{dc} = [T_{on} / (T_{on} + T_{off})] \times V_{fixed}$$

But

$$T_{on} + T_{off} = T_{total}$$

So
$$V_{dc} = [T_{on} / T_{total}] \times V_{fixed}$$

Here T_{on} / T_{total} is called duty cycle. So as duty cycle is more the average DC voltage supplied to motor is more and so speed of motor is increased. So as duty cycle is varied by varying on and off time of chopper, the speed of motor can be varied. The given circuit demonstrates one of such chopper circuit using Zero Cross Detector (ZCD), timer IC NE555 and darlington amplifier TIP122 used as chopper device. The circuit chops rectified DC output and varies the speed of DC motor.

Circuit Description

- 230V @ 50 Hz AC is applied at the primary of transformer T1 (0-12 VAC, 500 mA). It's secondary is connected with AC input terminals of bridge rectifier BR1.
- Rectified output is given to base of transistor Q1 through voltage divider formed by resistors R1 (1K) & R2 (1K).
- Collector output of Q1 is fed to base of transistor Q2 through R4 (470Ω). Q1 and Q2 both are connected in switch configuration as shown.
- The output of Q2 is applied at the trigger input of NE555 chip U1. It is configured in monostable mode. Timing components RV1 (10K pot) and C1 (1 μF) decides width of output pulse
- Output of U1 is applied to base of darlington transistor TIP122 through current limiting resistor R6
- The DC motor is connected between rectified output and collector of TIP122. The emitter of TIP122 is connected to ground

(Check the circuit diagram below for complete circuit for DC motor speed control using chopper)

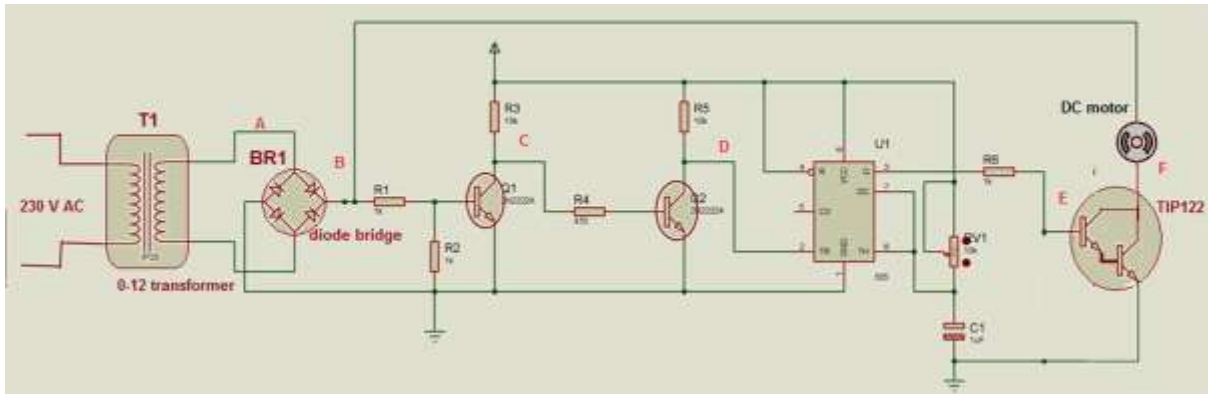

Circuit Operation

Let us understand the circuit operation with the help of waveforms at different points A, B, C, D, E and F

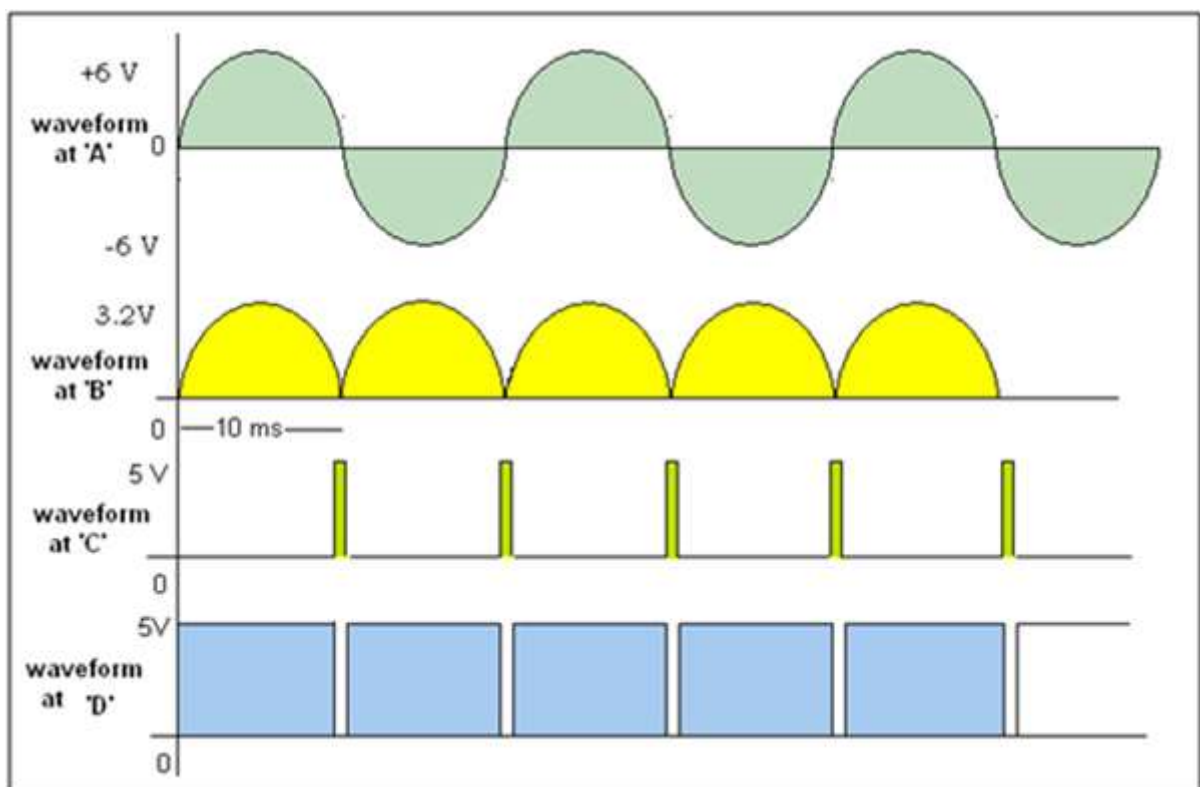

Fig. 2: Timing Diagram of Signals at various stages of the chopper circuit

- Step down transformer T1 steps down 230 V AC into 12 V AC as shown as waveform 1 above figure at point A

- This AC input is given to bridge rectifier. Bridge rectifier will produce rectified DC output as shown in second waveform if above figure at point B
- This rectified output is given to base of transistor Q1. Because transistor Q1 is connected in switch configuration, when the input at the base becomes lower than 0.7 V it comes into cutoff and produces very short duration positive pulse at point 'C'. That is shown as 3rd waveform in figure
- As these positive pulses are given to Q2 which is again connected in switch configuration, it will produce negative pulse at point 'D' of same width of positive pulse. This is shown as 4th waveform
- These negative pulses are applied to trigger input of NE555 chip connected in monostable mode. So, it will generate high output every time when it gets this negative pulse. Its time period can be varied from 0 milisecond to max 10 milisecond using 10 K pot
- As per the waveforms given in below figure let us understand 2 different cases with pulse width of NE555 3 ms and 8 ms
- As shown a second waveform in above figure, the NE555 will generate high output when gets negative pulse at its trigger input. For first case the width of pulse is 3 ms
- Because this pulse is given to base input of TIP122, it is turned ON till pulse is high. When TIP122 is ON the motor gets chopped rectified output as shown in 3rd waveform in figure. Out of total 10 ms time, the motor gets DC waveform for 3 ms only
- So average voltage applied to DC motor is less (as shown in waveform) and its speed is also less

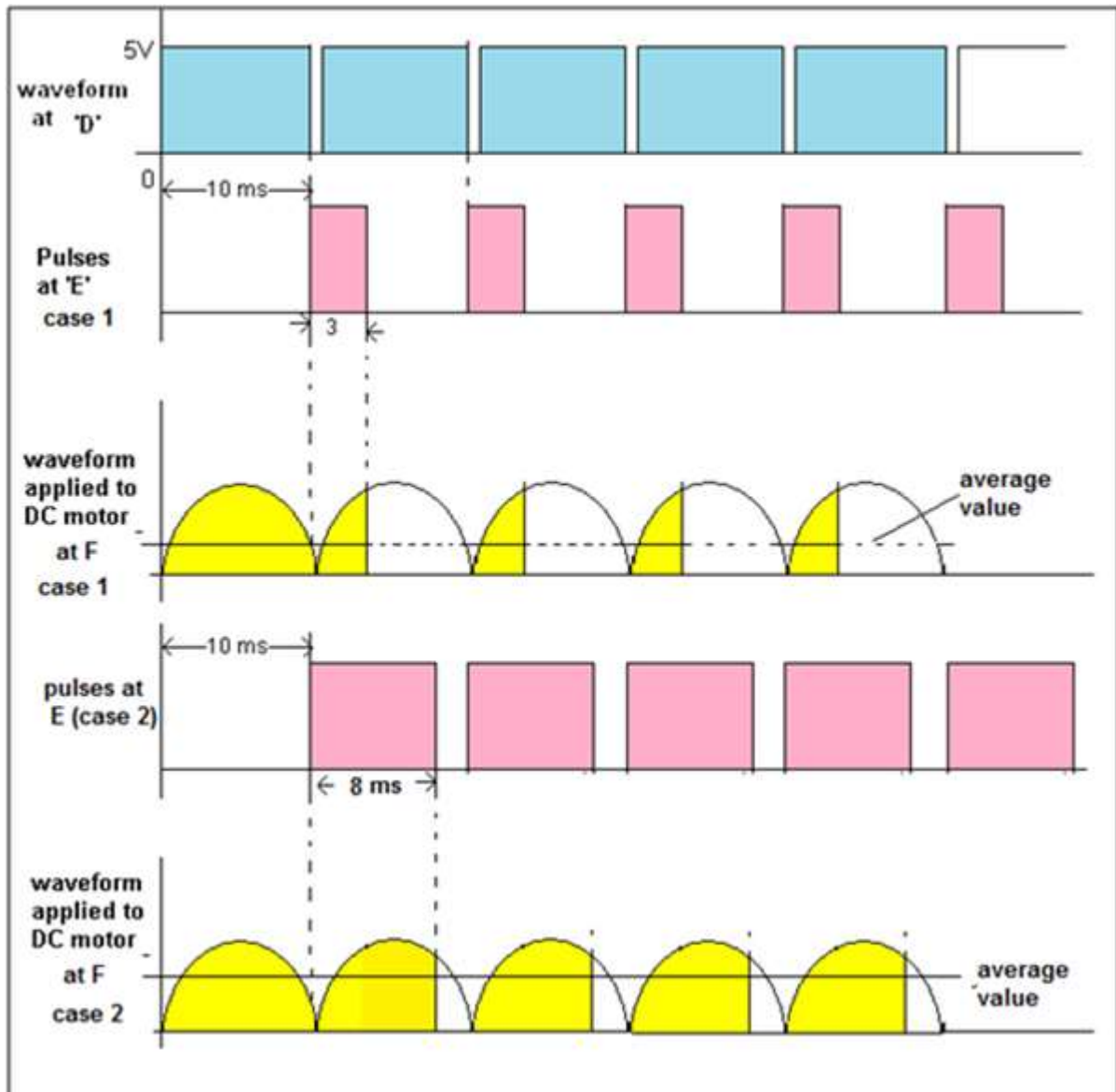

Fig. 3: Timing Diagram of Output Waveforms from the Chopper Circuit

- As shown in 4th and 5th waveforms, now the time period (pulse width) of NE555 is increased to 8 ms. So, the rectified output applied to DC motor is also more – means average voltage applied to motor is more and its speed is more
- Thus, as time period (width of output pulse) of NE555 is varied from 0 ms to 10 ms, it gives chopped rectified DC wave to motor that will vary its speed from min to max.

4.5 List the factors affecting speed of the AC motors

A three phase induction motor is basically a constant speed motor so it's somewhat difficult to control its speed. The speed control of induction motor is done at the cost of decrease in efficiency and low electrical power factor. Before discussing the methods to **control the speed of three phase induction motor** one should know the basic formulas of speed and torque of three phase induction motor as the methods of speed control depends upon these formulas.

Synchronous Speed

$$N_s = \frac{120f}{P}$$

Where, f = frequency and P is the number of poles

The speed of induction motor is given by,

$$N = N_s(1 - s)$$

Where,

N is the speed of the rotor of an induction motor,

N_s is the synchronous speed,

S is the slip.

The torque produced by three phase induction motor is given by,

$$T = \frac{3}{2\pi N_s} X \frac{sE_2^2 R_2}{R_2^2 + (sX_2)^2}$$

When the rotor is at standstill slip, s is one.

So the equation of torque is,

$$T = \frac{3}{2\pi N_s} X \frac{E_2^2 R_2}{R_2^2 + X_2^2}$$

Where,

E_2 is the rotor emf

N_s is the synchronous speed

R_2 is the rotor resistance

X_2 is the rotor inductive reactance

The Speed of Induction Motor is changed from Both Stator and Rotor Side. The speed control of three phase induction motor from stator side are further classified as:

- V / f control or frequency control.
- Changing the number of stator poles.
- Controlling supply voltage.
- Adding rheostat in the stator circuit.

The speed controls of three phase induction motor from rotor side are further classified as:

- Adding external resistance on rotor side.
- Cascade control method.

- Injecting slip frequency emf into rotor side.

Speed Control from Stator Side:

V / f Control or Frequency Control:

Whenever three phase supply is given to three phase induction motor rotating magnetic field is produced which rotates at synchronous speed given by

$$N_s = \frac{120f}{P}$$

In three phase induction motor emf is induced by induction similar to that of transformer which is given by

$$E \text{ or } V = 4.44\phi K.T.f \text{ or } \phi = \frac{V}{4.44KTf}$$

Where, K is the winding constant, T is the number of turns per phase and f is frequency. Now if we change frequency synchronous speed changes but with decrease in frequency flux will increase and this change in value of flux causes saturation of rotor and stator cores which will further cause increase in no load current of the motor. So, its important to maintain flux, ϕ constant and it is only possible if we change voltage. i.e if we decrease frequency flux increases but at the same time if we decrease voltage flux will also decrease causing no change in flux and hence it remains constant. So, here we are keeping the ratio of V/f as constant. Hence its name is V/ f method. For controlling the speed of three phase induction motor by V/f method we have to supply variable voltage and frequency which is easily obtained by using converter and inverter set.

Controlling Supply Voltage:

The torque produced by running three phase induction motor is given by

$$T \propto \frac{sE_2^2 R_2}{R_2^2 + (sX_2)^2}$$

In low slip region $(sX)^2$ is very very small as compared to R_2 . So, it can be neglected. So torque becomes

$$T \propto \frac{sE_2^2}{R_2}$$

Since rotor resistance, R_2 is constant so the equation of torque further reduces to

$$T \propto sE_2^2$$

We know that rotor induced emf $E_2 \propto V$. So, $T \propto sV^2$.

The equation above clears that if we decrease supply voltage torque will also decrease. But for supplying the same load, the torque must remain the same, and it is only possible if we increase the slip and if the slip increases the motor will run at a reduced speed. This method of speed control is rarely used because a small change in speed requires a large reduction in voltage, and hence the

current drawn by motor increases, which cause overheating of the induction motor.

Changing the number of stator poles:

The stator poles can be changed by two methods

(I) Multiple stator winding method.

(II) Pole amplitude modulation method (PAM)

Multiple Stator Winding Method:

In this method of speed control of three phase induction motor, we provide two separate windings in the stator. These two stator windings are electrically isolated from each other and are wound for two different numbers of poles. Using a switching arrangement, at a time, supply is given to one winding only and hence speed control is possible. Disadvantages of this method are that the smooth speed control is not possible. This method is more costly and less efficient as two different stator windings are required. This method of speed control can only be applied to squirrel cage motor.

Pole Amplitude Modulation Method (PAM):

In this method of speed control of three phase induction motor the original sinusoidal mmf wave is modulated by another sinusoidal mmf wave having the different number of poles.

Let $f_1(\theta)$ be the original mmf wave of induction motor whose speed is to be controlled.

$f_2(\theta)$ be the modulation mmf wave.

P_1 be the number of poles of induction motor whose speed is to be controlled.

P_2 be the number of poles of modulation wave.

$$f_1(\theta) = F_1 \sin \frac{P_1 \theta}{2}$$

$$f_2(\theta) = F_2 \sin \frac{P_2 \theta}{2}$$

After modulation resultant mmf wave

$$F_r(\theta) = F_1 F_2 \sin \frac{P_1 \theta}{2} \sin \frac{P_2 \theta}{2}$$

Apply formula for $2 \sin A \sin B = \cos \frac{A - B}{2} - \cos \frac{A + B}{2}$

So we get, resultant mmf wave

$$F_r(\theta) = F_1 F_2 \frac{\cos \frac{(P_1 - P_2)\theta}{2} - \cos \frac{(P_1 + P_2)\theta}{2}}{2}$$

Therefore the resultant mmf wave will have two different number of poles

i.e $P_{11} = P_1 - P_2$ and $P_{12} = P_1 + P_2$

Therefore by changing the number of poles we can easily change the speed of three phase induction motor.

- **Adding Rheostat in Stator Circuit**

In this method of speed control of three phase induction motor rheostat is added in the stator circuit due to this voltage gets dropped. In case of three phase induction motor torque produced is given by $T \propto sV_2^2$. If we decrease supply voltage torque will also decrease. But for supplying the same load, the torque must remain the same and it is only possible if we increase the slip and if the slip increase motor will run reduced speed.

Speed Control from Rotor Side:

- **Adding External Resistance on Rotor Side**

In this method of speed control of three phase induction motor external resistance are added on rotor side. The equation of torque for three phase induction motor is

$$T \propto \frac{sE_2^2 R_2}{R_2^2 + (sX_2)^2}$$

The three-phase induction motor operates in a low slip region. In low slip region term $(sX)^2$ becomes very very small as compared to R_2 . So, it can be neglected. and also E_2 is constant. So the equation of torque after simplification becomes,

$$T \propto \frac{s}{R_2}$$

Now if we increase rotor resistance, R_2 torque decreases but to supply the same load torque must remain constant. So, we increase slip, which will further result in the decrease in rotor speed. Thus, by adding additional resistance in the rotor circuit, we can decrease the speed of the three-phase induction motor. The main advantage of this method is that with an addition of external resistance

starting torque increases but this method of speed control of three phase induction motor also suffers from some disadvantages:

- The speed above the normal value is not possible.
- Large speed change requires a large value of resistance, and if such large value of resistance is added in the circuit, it will cause large copper loss and hence reduction in efficiency.
- Presence of resistance causes more losses.
- This method cannot be used for squirrel cage induction motor.

- **Cascade Control Method**

In this method of speed control of three phase induction motor, the two three-phase induction motors are connected on a common shaft and hence called cascaded motor. One motor is called the main motor, and another motor is called the auxiliary motor. The three-phase supply is given to the stator of the main motor while the auxiliary motor is derived at a slip frequency from the slip ring of the main motor.

Let N_{S1} be the synchronous speed of the main motor.

N_{S2} be the synchronous speed of the auxiliary motor.

P_1 be the number of poles of the main motor.

P_2 be the number of poles of the auxiliary motor.

F is the supply frequency.

F_1 is the frequency of rotor induced emf of the main motor.

N is the speed of set, and it remains same for both the main and auxiliary motor as both the motors are mounted on the common shaft.

S_1 is the slip of main motor.

$$S_1 = \frac{N_{S1} - N}{N_{S1}}$$

$$F_1 = S_1 F$$

The auxiliary motor is supplied with same frequency as the main motor i.e

$$F_1 = F_2$$

$$N_{S2} = \frac{120F_2}{P_2} = \frac{120F_1}{P_2}$$

$$N_{S2} = \frac{120S_1F}{P_2}$$

Now put the value of

$$S_1 = \frac{N_{S1} - N}{N_{S1}}$$

$$\text{We get, } N_{S2} = \frac{120F(N_{S1} - N)}{P_2 N_{S1}}$$

Now at no load, the speed of auxiliary rotor is almost same as its synchronous speed i.e $N = N_{S2}$

$$N = \frac{120F(N_{S1} - N)}{P_2 N_{S1}}$$

Now rearrange the above equation and find out the value of N, we get,

$$N = \frac{120F}{P_1 - P_2}$$

This cascaded set of two motors will now run at new speed having number of poles ($P_1 + P_2$). In the above method the torque produced by the main and auxiliary motor will act in same direction, resulting in number of poles ($P_1 + P_2$). Such type of cascading is called cumulative cascading. There is one more type of cascading in which the torque produced by the main motor is in opposite direction to that of auxiliary motor. Such type of cascading is called differential cascading; resulting in speed corresponds to number of poles ($P_1 - P_2$).

In this method of speed control of three phase induction motor, four different speeds can be obtained

- When only main induction motor work, having speed corresponds to .
- When only auxiliary induction motor work, having speed corresponds to .
- When cumulative cascading is done, then the complete set runs at a speed of .
- When differential cascading is done, then the complete set runs at a speed of .
- **Injecting Slip Frequency EMF into Rotor Side**

When the speed control of three phase induction motor is done by adding resistance in rotor circuit, some part of power called, the slip power is lost as I^2R losses. Therefore the efficiency of three phase induction motor is reduced by this method of speed control. This slip power loss can be recovered and supplied back to improve the overall efficiency of the three-phase induction motor, and this scheme of recovering the power is called slip power

recovery scheme and this is done by connecting an external source of emf of slip frequency to the rotor circuit. The injected emf can either oppose the rotor induced emf or aids the rotor induced emf. If it opposes the rotor induced emf, the total rotor resistance increases and hence the speed is decreased and if the injected emf aids the main rotor emf the total decreases and hence speed increases. Therefore by injecting induced emf in the rotor circuit, the speed can be easily controlled. The main advantage of this type of speed control of three phase induction motor is that a wide range of speed control is possible whether it is above normal or below normal speed.

List of the factors affecting speed of AC motor →
The speed of an Induction motor is given by

$$N_r = (1-s) N_s \quad \& \quad N_s = \frac{120f}{P}$$

$$\Rightarrow N_r = \frac{(1-s) \times 120f}{P} \quad \text{--- --- (1)}$$

From equation 1, we can vary the speed of an IM by varying frequency and no. of poles of an IM. Another so many methods are also present to control the speed of IM such methods are given by,

- ① Pole changing
- ② stator voltage control
- ③ supply frequency control
- ④ rotor resistance control
- ⑤ slip energy recovery control

But from the above methods there are two methods like frequency control and voltage control methods are generally used.

For synchronous motor :

$$N_s = \frac{120f}{P} \quad \text{--- --- (2)}$$

Common method to control the speed of the synchronous motor is supply frequency control method.

Speed control of Induction Motor by using AC voltage controller :-

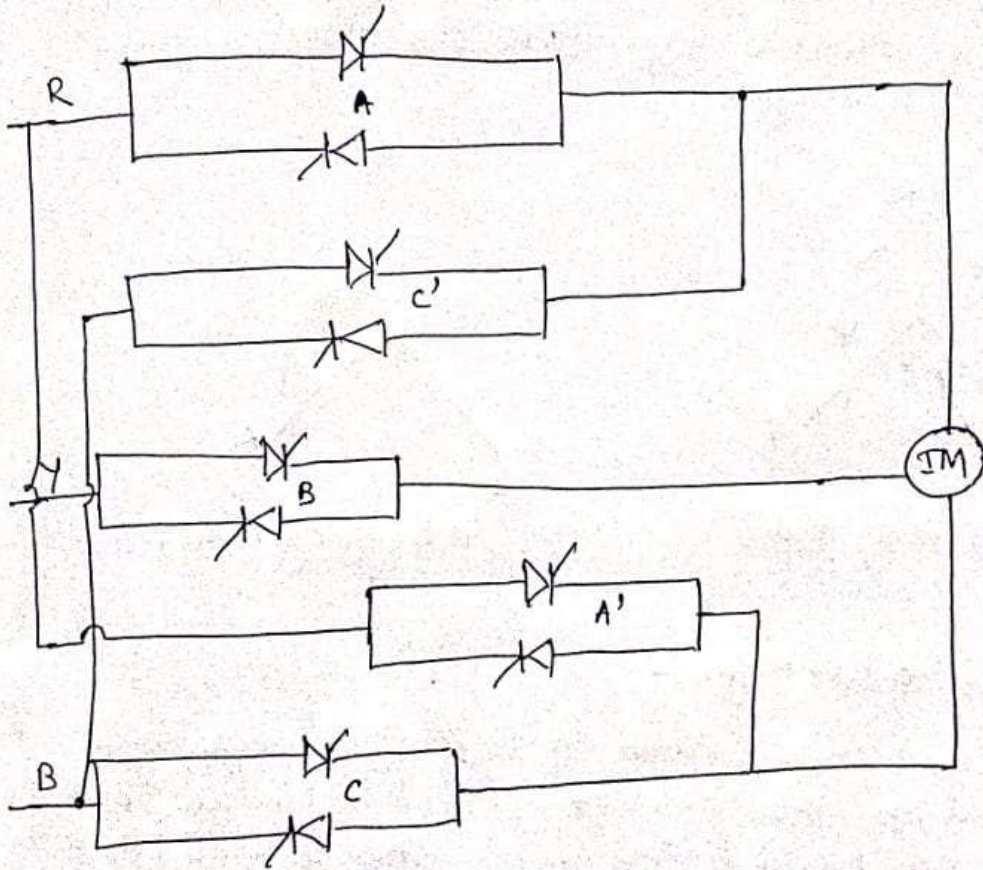

Here four quadrant operation with plugging is obtained by the using of the circuit given above.

Thyristor Pairs A,B,C provide operation in quadrant I and IV where as

A',B,C' thyristor pair provides operation in quadrant II and III

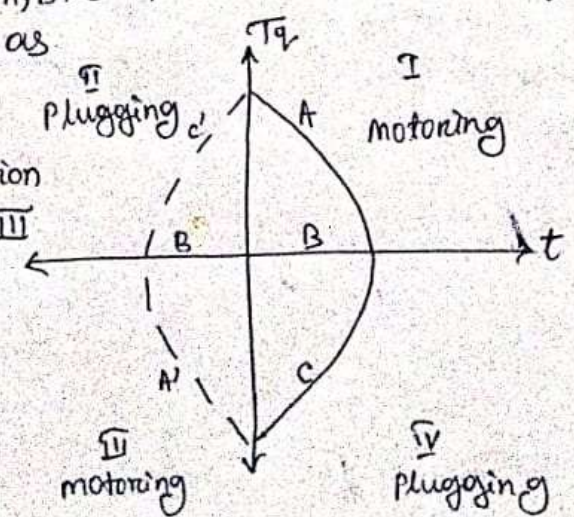

operation:-

while changing from one set of thyristor pairs to another, that is from ABC to A'BC' and viceversa, there should be taken to ensure that the incoming pair is activated only after the outgoing pair is fully turned off.

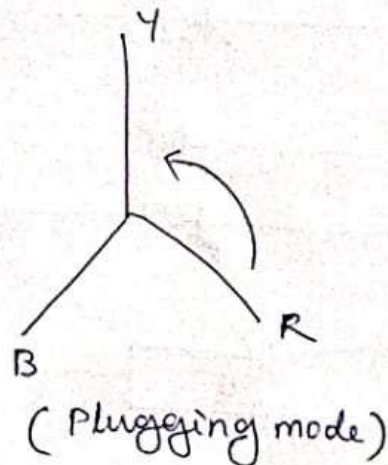
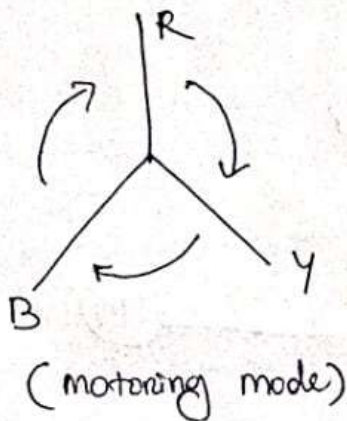

Some disadvantages:-

- (i) Output voltage depends on both delay angle and period of the current flow, which are directed by load power factor that's why if load changes then the output voltage of the controller changes continuously.
- (ii) Due to fluctuating the voltage and current then the harmonics are present which may cause eddy current in the core which causes the overheat of the IM.

12.8. SPEED CONTROL OF THREE-PHASE INDUCTION MOTORS

Three-phase induction motors are admirably suited to fulfil the demand of loads requiring substantially a constant speed. Several industrial applications, however, need adjustable speeds for their efficient operation. The object of the present section is to describe the basic principles of speed control techniques employed to three-phase induction motors through the use of power-electronics converters. The various methods of speed control through semiconductor devices are as under :

- (i) Stator voltage control
- (ii) Stator frequency control
- (iii) Stator voltage and frequency control
- (iv) Stator current control
- (v) Static rotor-resistance control
- (vi) Slip-energy recovery control.

Methods (i) to (iv) are applicable to both SCIMs and WRIMs whereas methods (v) and (vi) can be used for WRIMs only. These methods are now described in what follows.

12.8.1. Stator Voltage Control

It is seen from Eq. (12.50) that motor torque T_e is proportional to the square of the stator supply voltage. A reduction in the supply voltage will reduce the motor torque and therefore the speed of the drive. If the motor terminal voltage is reduced to KV_1 where $K < 1$, then the motor torque is given by

$$T_e = \frac{3}{\omega_s} \cdot \frac{(KV_1)^2}{\left(r_1 + \frac{r_2}{s}\right)^2 + (x_1 + x_2)^2} \cdot \frac{r_2}{s} \quad \dots(12.61)$$

For the purpose of varying the voltage applied to a 3-phase induction motor so as to achieve a speed control, a 3-phase ac voltage controller is usually employed. Fig. 12.27 (a) shows a three-phase ac voltage controller feeding a three-phase induction motor. By controlling the firing angle of the thyristors connected in antiparallel in each phase, the rms value of the stator voltage can be regulated. As a consequence, motor torque and thus speed of the drive is controlled. In Fig. 12.27 (b), for load torque T_L , a is the operating point at rated

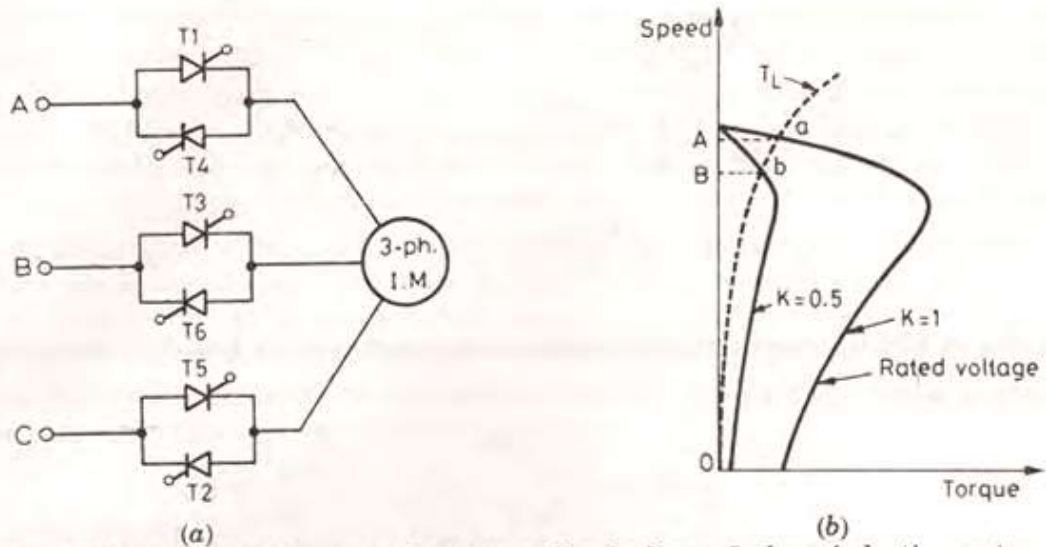

Fig. 12.27. (a) Three-phase ac voltage controller feeding a 3-phase induction motor
 (b) Speed-torque characteristics as effected by stator voltage control.

voltage and OA is the motor speed. For reduced stator voltage ($K = 0.5$), b is the operating point and OB is the reduced motor speed for load torque T_L . This method is suitable for motors having large value of s_m . For low-slip motors, the range of speed control is very narrow.

Stator-voltage-control method offers limited speed range. It is usual to use 3-phase voltage controllers. Their use, however, introduces pronounced harmonic contents and input supply power factor for the voltage controller is quite low. These are, therefore, used for low-power drives like fans, blowers and centrifugal pumps requiring low starting torque. For these types of loads, the load torque is proportional to speed squared and input current is maximum when slip $s = 1/3$, this is proved in Example 12.22.

12.8.2. Stator Frequency Control

By changing the supply frequency, motor synchronous speed can be altered and thus torque and speed of a 3-phase induction motor can be controlled. For a three-phase induction motor, per-phase supply voltage is $V_1 = \sqrt{2} \pi f_1 N_1 \phi k_w$. This expression shows that under

rated voltage and frequency operation, flux will be rated. In case supply frequency is reduced with constant V_1 , the air-gap flux increases and the induction motor magnetic circuit gets saturated. The motor parameters will change leading to inaccurate speed-torque characteristics. Further, at low frequencies, reactances will be low leading to high motor currents, more losses and reduced efficiency. In view of this, induction motor (I.M.) speed control with constant supply voltage and reduced supply frequency is rarely used in practice.

With constant supply voltage, if the supply frequency is increased, the synchronous speed and therefore motor speed rises. But, with increase in frequency, flux and torque also get reduced. IM performance at constant voltage and increased frequency can be obtained by neglecting X_m and r_1 from the equivalent circuit of Fig. 12.25 (a). This assumption is not going to introduce any noticeable error as magnetizing current at high frequency is quite small. Thus, rotor current under this assumption is given by

$$I_2 = \frac{V_1}{\left[\left(\frac{r_2}{s} \right)^2 + (x_1 + x_2)^2 \right]^{1/2}} \quad \dots(12.62)$$

Synchronous speed, $\omega_s = \frac{4\pi f_1}{P} = \frac{2\omega_1}{P} \text{ rad/s}$

Motor torque, $T_e = \frac{3}{\omega_s} \cdot I_2^2 \frac{r_2}{s}$

$$= \frac{3P}{2\omega_1} \cdot \frac{V_1^2}{\left(\frac{r_2}{s} \right)^2 + (x_1 + x_2)^2} \cdot \frac{r_2}{s} \quad \dots(12.63)$$

Slip, $s = \frac{f_2}{f_1} = \frac{\omega_2}{\omega_1}$ or $\omega_2 = s \omega_1$

Here f_2 and ω_2 are the rotor frequencies in Hz and rad/s respectively. Substituting the value of slip $s = \frac{\omega_2}{\omega_1}$ in Eq. (12.63), we get

$$T_e = \frac{3P}{2\omega_1} \cdot \frac{V_1^2 \cdot \omega_1}{\frac{r_2 \cdot \omega_1^2}{\omega_2^2} + \omega_1^2 (l_1 + l_2)} \cdot \frac{r_2}{\omega_2}$$

$$= \frac{3P}{2\omega_1^2} \cdot \frac{V_1^2 \cdot \omega_2}{r_2^2 + \omega_2^2 (l_1 + l_2)^2} \cdot r_2 \quad \dots(12.64)$$

Slip at which maximum torque occurs is obtained from Fig. 12.25 (a) as

$$s_{mt} = \frac{r_2}{x_1 + x_2} \quad \dots(12.65)$$

Rotor frequency in rad/s at which maximum torque occurs is given by

$$\omega_{2m} = s_{mT} \cdot \omega_1 = \frac{\omega_1 \cdot r_2}{\omega_1 (l_1 + l_2)} = \frac{r_2}{l_1 + l_2}$$

Note that ω_{2m} does not depend on the supply frequency ω_1 . Substituting $r_2 = \omega_{2m} \cdot (l_1 + l_2)$ in Eq. (12.64) gives maximum torque $T_{e,m}$ as

$$T_{e.m} = \frac{3P}{2\omega_1^2} \cdot \frac{V_1^2 \cdot \omega_{2m}^2 \cdot (l_1 + l_2)}{\omega_{2m}^2 (l_1 + l_2)^2 + \omega_{2m}^2 (l_1 + l_2)^2}$$

$$= \frac{3P}{2\omega_1^2} \cdot \frac{V_1^2}{l_1 + l_2} \quad \dots(12.66)$$

Eq. (12.66) indicates that T_{em} is inversely proportional to supply-frequency squared. Also,

$$T_{em} \cdot \omega_1^2 = \frac{3P}{2} \cdot \frac{V_1^2}{l_1 + l_2}$$

At given source voltage V_1 , $\frac{3P}{2} \cdot \frac{V_1^2}{l_1 + l_2}$ is constant, therefore, $T_{em} \cdot \omega_1^2$ is also constant. As the operating frequency ω_1 is increased, $T_{em} \cdot \omega_1^2$ remains constant but maximum torque at increased frequency ω_1 gets reduced as shown in Fig. 12.28. Supposing rated frequency for a motor is 50 Hz and $T_{e.m} = 100$ Nm. If the motor is now operated at 100 Hz, then $100 (2\pi \times 50)^2 = (\text{new maximum torque}) (2\pi \times 100)^2$ or the maximum torque at increased frequency of 100 Hz is 25 Nm. Such type of IM behaviour is similar to the working of dc series motors. With constant voltage and increased-frequency operation, air-gap flux gets reduced; therefore, during this control, IM is said to be working in *field-weakening mode*. Constant voltage and variable frequency control of Fig. 12.28 can be obtained by feeding 3-phase IM through three-phase inverters discussed in Chapter 8.

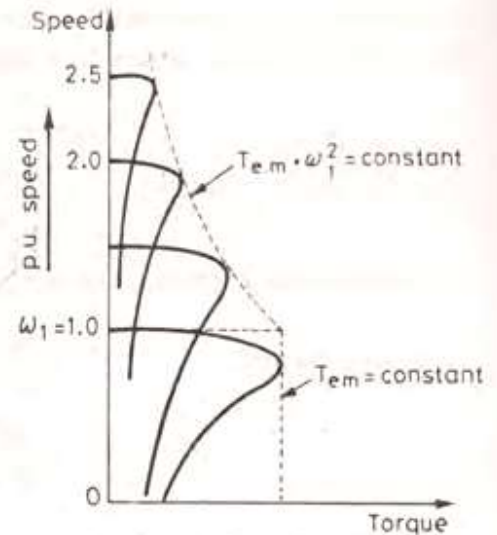

Fig. 12.28. Speed torque characteristics of a 3-phase IM with stator frequency control with constant supply voltage.

12.8.3. Stator Voltage and Frequency Control

For a 3-phase IM, stator voltage per phase is given by

$$V_1 = \sqrt{2} \pi f_1 \cdot N_{ph1} \cdot \phi_1 \cdot k_{\omega 1} \quad \dots(12.66)$$

It is seen from above equation that if the ratio of supply voltage V_1 to supply frequency f_1 is kept constant, the air-gap flux ϕ_1 remains constant. From Fig. 12.25 (b) and Eq. (12.50), the starting torque is given by

$$T_{e.st} = \frac{3}{\omega_s} \cdot \frac{V_1^2}{(r_1 + r_2)^2 + (x_1 + x_2)^2} \cdot r_2$$

As $(r_1 + r_2) \ll (x_1 + x_2)$ and $\omega_s = \frac{2\omega_1}{P}$, we get

$$\begin{aligned} T_{e.st} &= \frac{3P}{2\omega_1} \cdot \frac{V_1^2 \cdot r_2}{\omega_1^2 (l_1 + l_2)^2} \\ &= \frac{3P}{2\omega_1} \cdot \left(\frac{V_1}{\omega_1}\right)^2 \cdot \frac{r_2}{(l_1 + l_2)^2} \end{aligned} \quad \dots(12.67)$$

From Eq. (12.56), maximum torque is given by

$$\begin{aligned} T_{e.m} &= \frac{3}{\omega_s} \cdot \frac{V_1^2}{2(x_1 + x_2)} \\ &= \frac{3P}{2\omega_1} \cdot \frac{V_1^2}{2 \cdot \omega_1 (l_1 + l_2)} \\ &= \frac{3P}{4} \cdot \left(\frac{V_1}{\omega_1}\right)^2 \frac{1}{l_1 + l_2} \end{aligned} \quad \dots(12.68)$$

Eq. (12.68) shows that if V_1/ω_1 , or air-gap flux ϕ_1 , is kept constant, the maximum torque remains unaltered. Eq. (12.67) indicates that starting torque increases even if air-gap flux is kept constant. At low values of frequencies, the effect of resistances cannot be neglected as compared to the reactances. This has the effect of reducing the magnitude of maximum torque at lower frequencies as shown in Fig. 12.29. In practice, at low frequencies, the supply voltage is increased to maintain the level of maximum torque. This method of speed control is also called *volts/hertz control*.

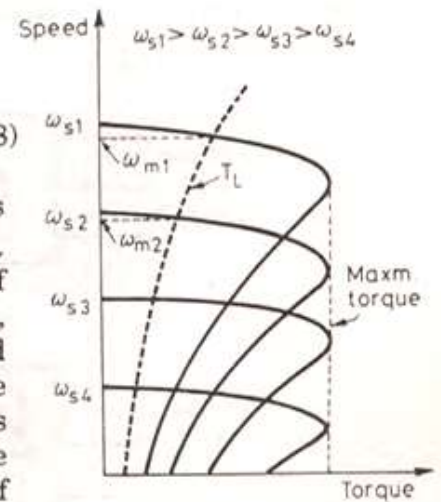

Fig. 12.29. Speed-torque characteristics of a 3-phase IM with volts/hertz control.

If stator resistance is neglected, then from Fig. 12.25 (b), the slip at which maximum torque occurs is given by

$$s_m = \frac{r_2}{x_1 + x_2}$$

$$= \frac{r_2}{\omega_1 (l_1 + l_2)} \quad \dots(12.69)$$

As the supply frequency ω_1 is reduced, the slip at maximum torque increases.

In Fig. 12.29, load torque T_L for a certain load is also shown. It is seen from this figure that as both voltage and frequency are varied (usually below their rated values), speed of the drive can be controlled. The control of both voltage and frequency can be carried out (so as to keep $\frac{V}{f}$ constant) through the use of three-phase inverters or cycloconverters. Inverters are used in low and medium power drives whereas cycloconverters are suitable for high-power drives like cement mills, locomotives etc.

Variable voltage and variable frequency can be obtained from voltage-source inverters. Four such circuit configurations are shown in Fig. 12.30. In Fig. 12.30 (a), three-phase ac is converted to constant dc by diode rectifier. Voltage and frequency are both varied by PWM inverter. The circuitry between the rectifier and the inverter consists of an inductor L and

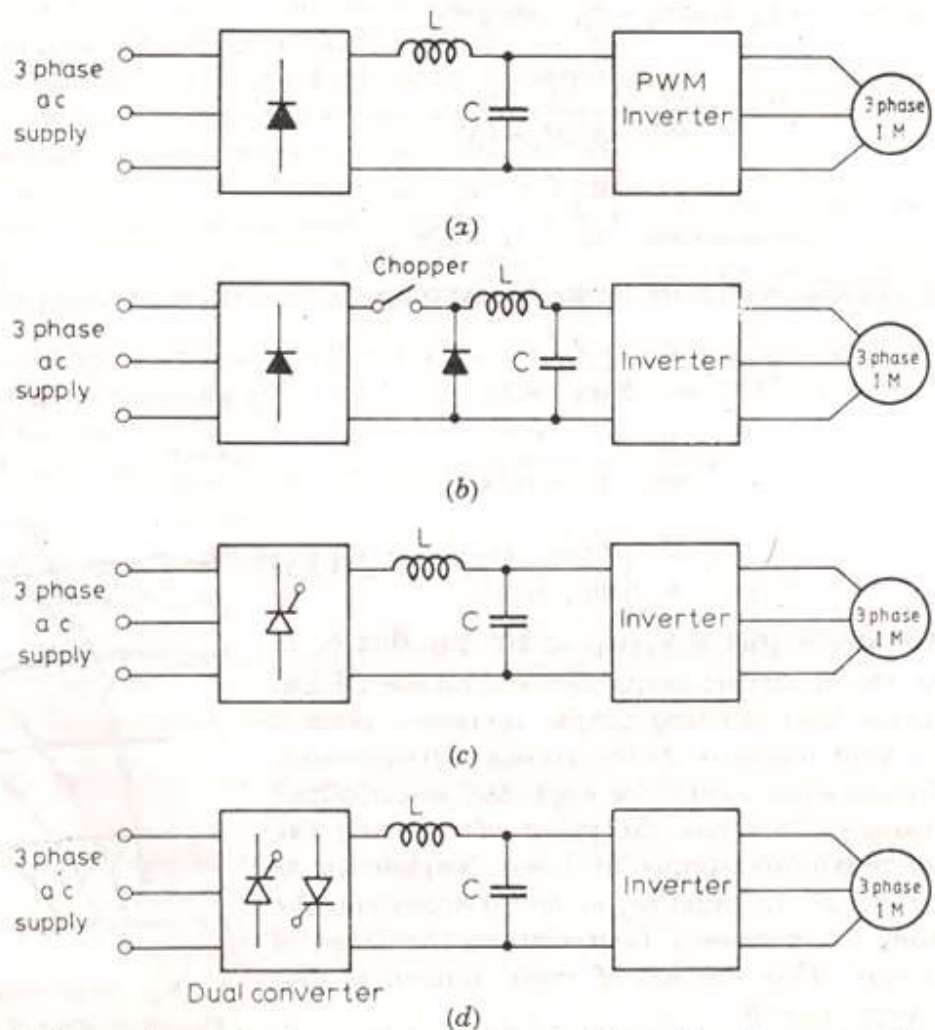

Fig. 12.30. Three-phase induction motor speed control through voltage source inverters.

capacitor C , called filter circuit. The function of filter circuit is to smooth dc input voltage to the inverter. This circuitry in between rectifier and inverter is called *dc link*. In Fig. 12.30 (a), regeneration is not possible because of diode rectifier. Also, inverter would inject harmonics into the 3-phase ac supply.

In Fig. 12.30 (b), three-phase ac is converted to dc by diode rectifier. Chopper varies the dc input voltage to the inverter and frequency is controlled by the inverter. Use of chopper reduces the harmonic injection into the ac supply. Regeneration is not feasible in the scheme of Fig. 12.30 (b).

Fig. 12.30 (c) uses a 3-phase controlled rectifier, dc link consisting of L and C and a force-commutated VSI. Voltage is regulated by controlled rectifier and frequency is varied within the inverter. Here regeneration is possible if three-phase full converter is used. Regeneration is also feasible in the scheme shown in Fig. 12.30 (d). It uses a 3-phase dual converter, L-C filter and inverter. Level of dc input voltage to the inverter is regulated in dual converter whereas frequency is varied within the VSI inverter.

It may be observed from above that volts/hertz control offer speed control from standstill upto rated speed of IM. This method is similar to the armature-voltage control method used for the speed control of a dc motor.

4.8 WORKING OF UPS WITH BLOCK DIAGRAM

There are several applications where even a temporary power failure can cause a great deal of public inconvenience leading to large economic losses. Examples of such applications are major computer installations, process control in chemical plants, safety monitors, general communication systems, hospital intensive care units etc. For such critical loads, it is of paramount importance to provide an uninterruptible power supply (UPS) system so as to maintain the continuity of supply in case of power outages.

Earlier UPS systems were based on an arrangement shown in Fig. 11.7. This scheme is usually called rotating-type UPS. This arrangement consists of DC motor-driven alternator, the shaft of which is also coupled to a diesel engine. The three-phase mains supply, after rectification, charges a dc battery-bank and feeds the dc motor as well. The uninterruptible

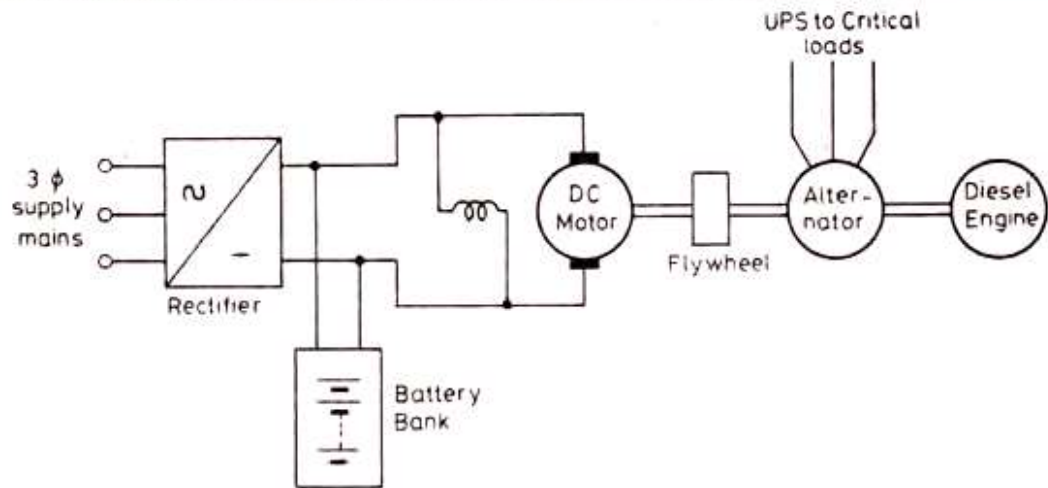

Fig. 11.7. Rotating-type UPS system based on dc motor/alternator set.

power supply needed is taken from the alternator output terminals. When mains supply fails, the diesel engine is run to take over the load. Starting of the diesel engine takes 10 to 15 seconds. During this period, the battery-bank is able to maintain the alternator speed through the dc motor and the flywheel, thus giving a no-break supply to the critical load. At present, however, static UPS systems are becoming popular up to a few kVA ratings.

Static UPS systems are of two types ; namely short-break UPS and no-break UPS. In short-break UPS, the load gets disconnected from the power source for a short duration of the order of 4 to 5 ms. In no-break UPS, load gets continuous uninterrupted supply from the power source. These are now discussed briefly.

Short-break UPS. In situations where short interruption (4 to 5 ms) in supply can be tolerated, the short-break UPS shown in Fig. 11.8 is used. In this system, main ac supply is rectified to dc. This dc output from the rectifier charges the batteries and is also converted

to ac by an inverter, Fig. 11.8. After passing through the filter, ac can be delivered to load in case normally-off contacts are closed. Under normal circumstances, normally-on contacts are closed and normally-off contacts are open and the main supply delivers ac power to the load. At the same time, the rectifier supplies continuous trickle charge to batteries to keep them fully charged. In the event of power outage, normally-off switch is turned-on and the batteries deliver ac power to critical load through the inverter and filter. A momentary interruption in

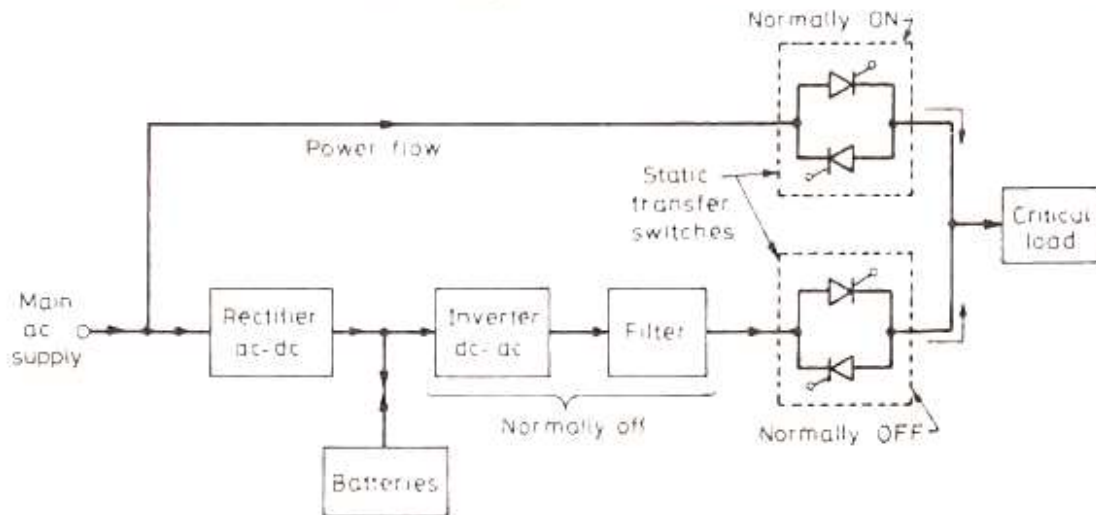

Fig. 11.8. Short-break static UPS configuration.

the supply (4 to 5 ms) to the load can be observed in case lamps and fluorescent tubes are a part of the load. When normally-on switch is opened and normally-off switch is turned on, lamps will have a transient dip in their illumination whereas the fluorescent tubes will be off momentarily and then get turned on. When the main ac supply appears, critical load gets connected, through normally-on switch, to the supply mains. Again, a momentary interruption in the illumination is noticed. The arrangement shown in Fig. 11.8 is also referred to as *stand-by power supply*.

No-break UPS. When a no-break supply is required, the static UPS system shown in Fig. 11.9 is used. In this system, main ac supply is rectified and the rectifier delivers power to maintain required charge on the batteries. Rectifier also supplies power to inverter continuously which is then given to ac-type load through filter and normally-on switch. In case of main-supply failure, batteries at once take over with no-break of supply to the critical load. No dip or discontinuity in the illumination is observed in case of no-break UPS. This configuration of Fig. 11.9 has the following additional advantages :

- (i) The inverter can be used to condition the supply delivered to load.
- (ii) Load gets protected from transients in the main ac supply.
- (iii) Inverter output frequency can be maintained at the desired value.

In case inverter failure is detected, the load is switched on to the main ac supply directly by turning on the normally-off static switch and opening the normally-on static switch. The transfer of load from inverter to main ac supply takes 4 to 5 ms by static transfer switch as compared to 40 to 50 ms for a mechanical contactor. After inverter fault is cleared, uninterruptible power supply is again restored to the load through the normally on switch. The batteries are now recharged from the main supply by adjusting the charger at maximum charge rate so that batteries are charged to their full capacity in the shortest possible time.

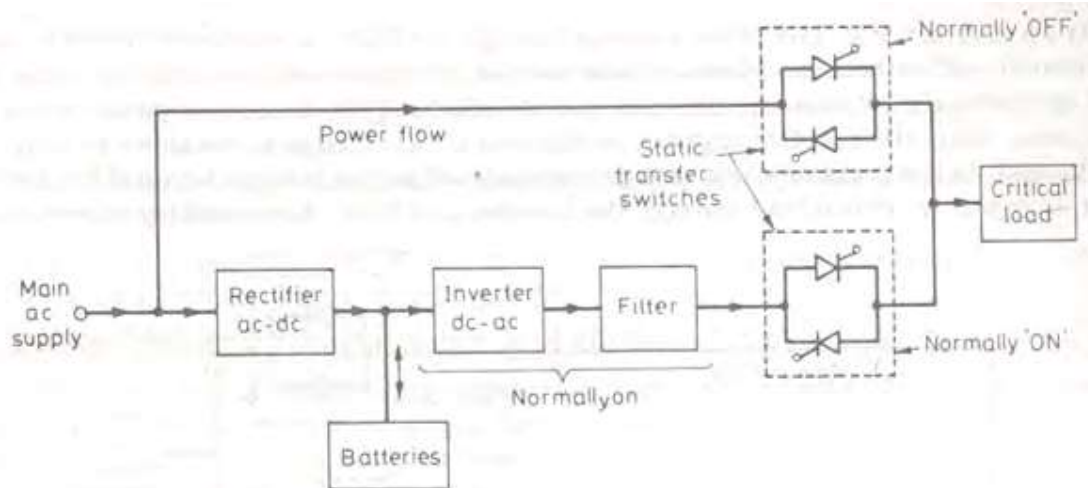

Fig. 11.9. No-break UPS configuration.

The standby batteries in the UPS system are either nickel-cadmium (NC) or lead-acid type. NC batteries have the following advantages :

- (a) Their electrolyte is non-corrosive.
- (b) Their electrolyte does not emit an explosive gas when charging.
- (c) NC batteries cannot be damaged by overcharging or discharging, these have therefore longer life.

Cost of NC batteries is, however, two or three times that of lead-acid batteries.

The time period for which a battery or a battery-bank can deliver power to load through inverter at the required voltage level depends upon (i) the size of the batteries and (ii) nature of the load.

4.10 BASIC SWITCHED MODE POWER SUPPLY (SMPS)

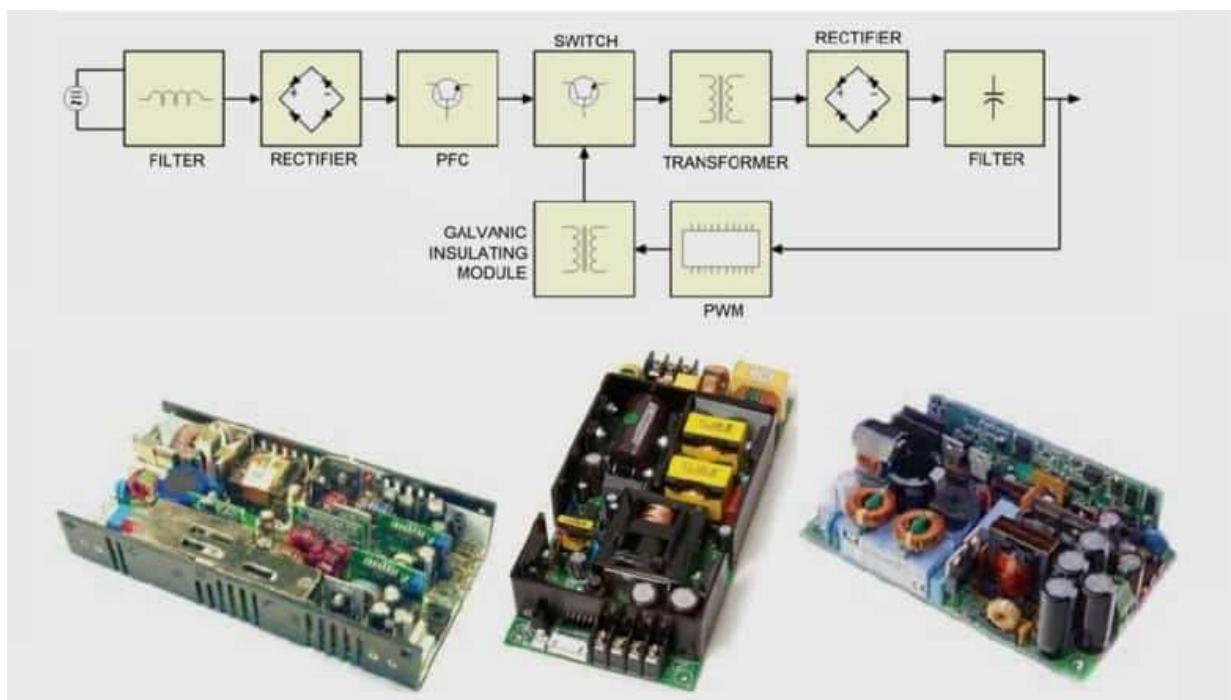

SMPS stands for switched mode power supply. It is known by a wide range of names like **power supply, supply unit, regulator, or switcher** in an electronic power supply. It incorporates a **switching regulator** to convert electrical power efficiently. It is mainly used for obtaining a **controlled dc power supply** as output.

It is used to convert power (voltage) using switching devices that are turned on and off alternatively at high frequencies. It uses storage components like **inductors** or **capacitors** to supply power when the switching device is in its non-conduction state (off-state). SMPS possesses **high efficiency** and is widely used in various electronic equipment such as computers, battery chargers, and other sensitive equipment requiring a **stable and efficient power supply**.

The **working & design** of SMPS is divided into various sections and stages.

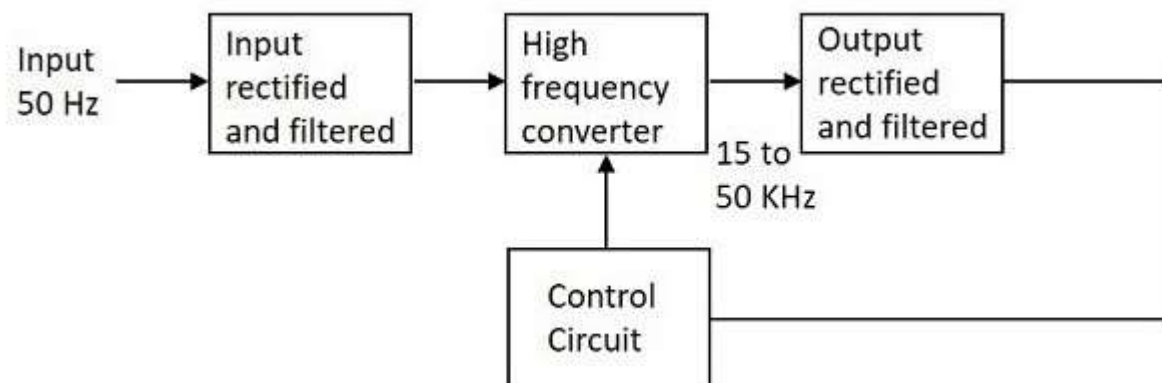

1: Input Stage

The AC input supply of frequency (**50-60**) Hz feeds directly to the **rectifier** and filter **circuit**. Its output contains many variations and the **capacitance value** of the capacitor should be higher enough to handle the input fluctuations. Finally, the **unregulated dc** is given to the central switching section of SMPS in order to regulate it. This section does not contain any transformer for the step down in **input voltage supply**.

2: Switching Section

It consists of **fast switching devices** like a **Power transistor** or a **MOSFET**, which switches ON and OFF according to the variations in the voltage. The output obtained is given to the primary of the **transformer** which is present in this section.

The transformer used here is a much smaller, lighter, and highly effective one that steps down voltage. These are much efficient compared to other step-down methods. Hence, the **power conversion ratio** is higher.

3: Output Stage

The output that is derived from the switching section is again rectified and filtered. It uses a rectification and filter circuit to get the desired DC voltage. The obtained **regulated output voltage** is then given to the **control circuit**.

4: Control Unit

This unit is all about **feedback**, which has many sections contain in it. Lets see the brief information about this section.

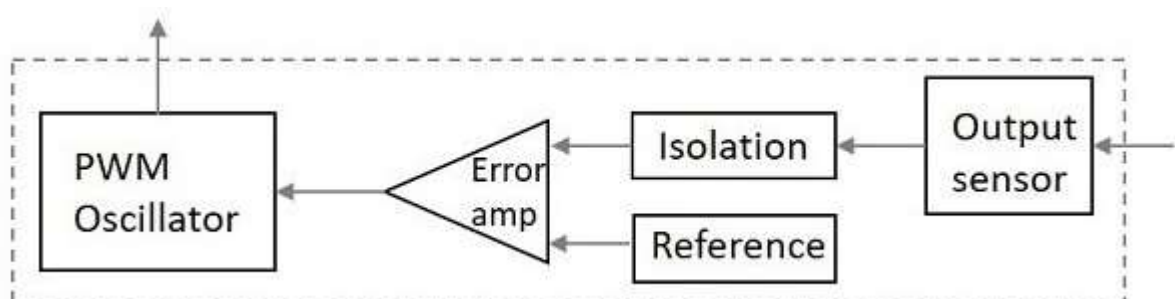

The inner control unit consists of an **oscillator**, **amplifier**, **sensor**, etc. The sensor senses the **output signal** and **feedback** to the control unit. All the signals

are isolated from each other so that, any sudden spikes should not affect the circuitry. The **reference voltage** is given as one input along with the signal to the **error amplifier**. The amplifier is a **comparator** that compares the signal with the required signal level.

The next stage is **Controlling the chopping frequency**. The final voltage level is controlled by comparing the inputs given to the error amplifier, whose output helps to decide whether to increase or to decrease the chopping frequency.

The **oscillator** produces a standard PWM wave with a fixed frequency.

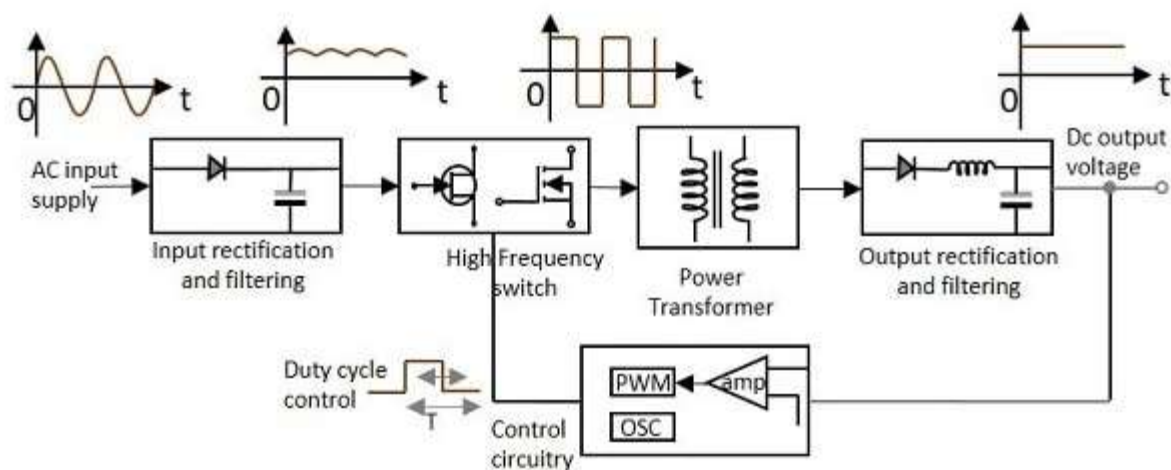

Types of SMPS:

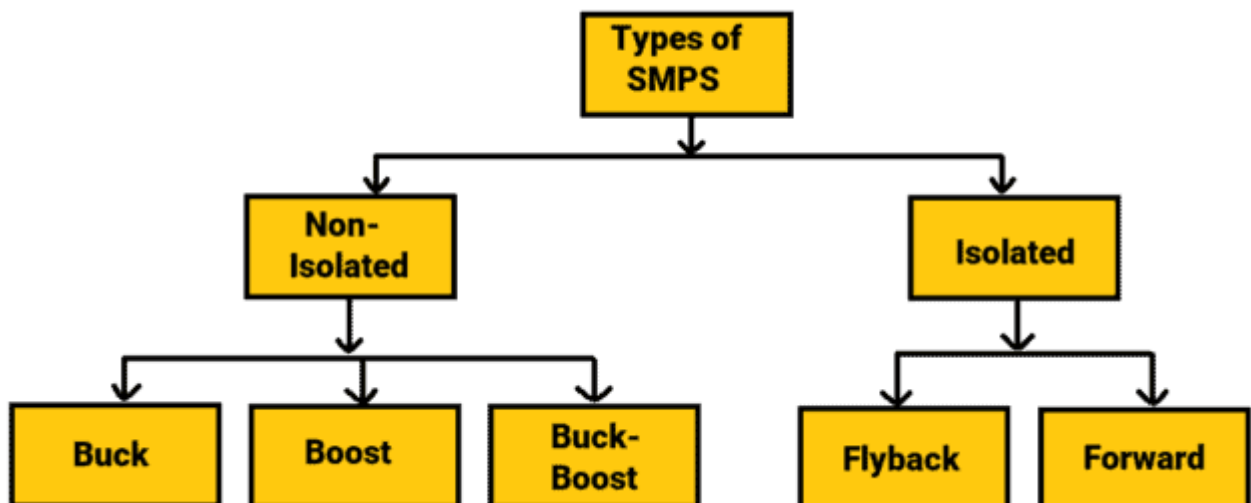

1: Non-isolated

Non-isolated converters are mostly used when the change in the voltage is comparatively small. The non-isolated SMPS are the ones whose input and output circuitry are not isolated from each other. The major disadvantage is that it cannot provide **protection** from **high electrical voltages** and it poses more noise. They are of 3 types.

I: Buck

In a typical non-isolated step-down (buck) converter the output voltage V_{OUT} depends on the input voltage V_{IN} and the switching duty cycle of the power switch.

II: Boost

It is used to boost voltage and it uses the same number of passive components but arranged to step up the input voltage so that the output is higher than that of the input.

III: Buck-Boost

This converter allows the input voltage to be either stepped-up or stepped-down, depending on the duty cycle. The output voltage is given by the relation $V_{OUT} = -V_{IN} * D / (1-D)$

2: Isolated

Isolated SMPS are the ones where there is isolation maintained between the input and output circuitry. The supplies make use of a transformer to separate the switching from the output. The secondary winding of the transformer acts as the energy storing element.

I: Fly-back Converter:

The working of this converter is similar to the buck-boost converter of the non-isolating category. The only difference is that it uses a transformer to store energy instead of an inductor in the circuit.

II: Forward Converter

The working of this converter makes use of the transformer to send the energy, between the input and output in a single step.

Application of Switched Mode power supply (SMPS)

- It is used in servers, power stations, and personal computers.
- It is used in vehicles for charging batteries.
- It is used in factories and industries for power.
- It is used in the railway system, security system.
- It is also used in mobile and also as lighting.

MODULE-5

PLC AND ITS APPLICATIONS

5.1 Introduction of Programmable Logic Controller (PLC)

Programmable logic controllers are now the most widely used industrial process control technology. A programmable logic controller (PLC) is an industrial grade computer that is capable of being programmed to perform control functions. The programmable controller has eliminated much of the hardwiring associated with conventional relay control circuits. Other benefits include easy programming and installation, high control speed, network compatibility, troubleshooting and testing convenience, and high reliability. The programmable logic controller is designed for multiple input and output arrangements, extended temperature ranges, immunity to electrical noise, and resistance to vibration and impact. Programs for the control and operation of manufacturing process equipment and machinery are typically stored in battery-backed or non-volatile memory. A PLC is an example of a real-time system since the output of the system controlled by the PLC depends on the input conditions. The programmable logic controller is, then, basically a digital computer designed for use in machine control. Unlike a personal computer, it has been designed to operate in the industrial environment and is equipped with special input/output interfaces and a control programming language. The common abbreviation used in industry for these devices, PC, can be confusing because it is also the abbreviation for “personal computer.” Therefore, most manufacturers refer to their programmable controller as a PLC, which stands for “programmable logic controller.”

5.2 Advantages of PLC

Programmable controllers offer several advantages over a conventional relay type of control. Relays have to be hardwired to perform a specific function. When the system requirements change, the relay wiring has to be changed or modified. In extreme cases, such as in the auto industry, complete control panels had to be replaced since it was not economically feasible to rewire the old panels with each model changeover. The programmable controller has eliminated much of the hardwiring associated with conventional relay control circuits. It is small and inexpensive compared to equivalent relay-based process control systems. Modern control systems still include relays, but these are rarely used for logic. In addition to cost savings, PLCs provide many other benefits including:

- *Increased Reliability.* Once a program has been written and tested, it can be easily downloaded to other PLCs. Since all the logic is contained in the PLC’s memory, there is no chance of making a logic wiring error. The program takes the place of much of the external wiring that would normally be required for

control of a process. Hardwiring, though still required to connect field devices, is less intensive. PLCs also offer the reliability associated with solid-state components.

- *More Flexibility.* It is easier to create and change a program in a PLC than to wire and rewire a circuit. With a PLC the relationships between the inputs and outputs are determined by the user program instead of the manner in which they are interconnected. Original equipment manufacturers can provide system updates by simply sending out a new program. End users can modify the program in the field, or if desired, security can be provided by hardware features such as key locks and by software passwords.
- *Lower Cost.* PLCs were originally designed to replace relay control logic, and the cost savings have been so significant that relay control is becoming obsolete except for power applications. Generally, if an application has more than about a half-dozen control relays, it will probably be less expensive to install a PLC.
- *Communications Capability.* A PLC can communicate with other controllers or computer equipment to perform such functions as supervisory control, data gathering, monitoring devices and process parameters, and download and upload of programs.
- *Faster Response Time.* PLCs are designed for highspeed and real-time applications. The programmable controller operates in real time, which means that an event taking place in the field will result in the execution of an operation or output. Machines that process thousands of items per second and objects that spend only a fraction of a second in front of a sensor require the PLC's quick-response capability.
- *Easier to Troubleshoot.* PLCs have resident diagnostics and override functions that allow users to easily trace and correct software and hardware problems. To find and fix problems, users can display the control program on a monitor and watch it in real time as it executes.

5.3 Different parts of PLC by drawing the block diagram and purpose of each part of PLC

A typical PLC can be divided into parts, as illustrated in Figure 1-8. These are the *central processing unit (CPU)*, the *input/output (I/O)* section, the *power supply*, and the *programming device*.

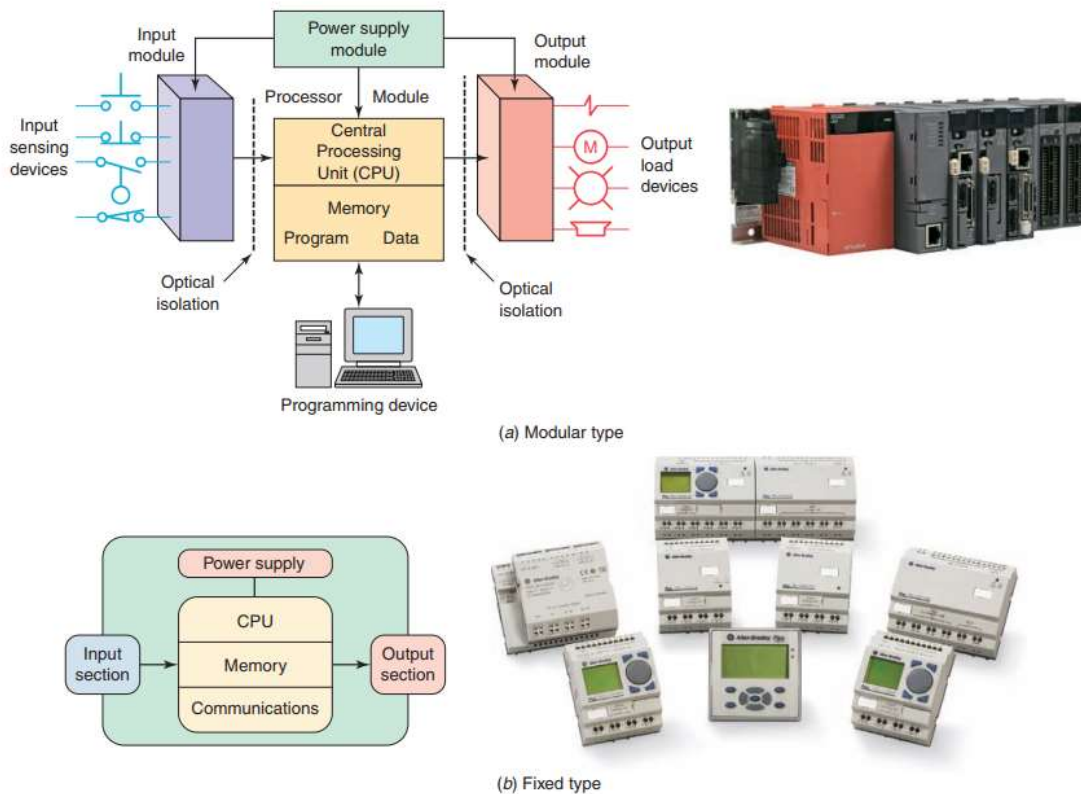

Figure 1-8 Typical parts of a programmable logic controller.
 Source: (a) Courtesy Mitsubishi Automation; (b) Image Used with Permission of Rockwell Automation, Inc.

The term *architecture* can refer to PLC hardware, to PLC software, or to a combination of both. An *open* architecture design allows the system to be connected easily to devices and programs made by other manufacturers.

There are two ways in which I/Os (Inputs/Outputs) are incorporated into the PLC: fixed and modular. *Fixed I/O* is typical of small PLCs that come in one package with no separate, removable units. The processor and I/O are packaged together, and the I/O terminals will have a fixed number of connections built in for inputs and outputs. The main advantage of this type of packaging is lower cost. The number of available I/O points varies and usually can be expanded by buying additional units of fixed I/O. One disadvantage of fixed I/O is its lack of flexibility; you are limited in what you can get in the quantities and types dictated by the packaging. Also, for some models, if any part in the unit fails, the whole unit has to be replaced.

Modular I/O is divided by compartments into which separate modules can be plugged. This feature greatly increases your options and the unit's flexibility. You can choose from the modules available from the manufacturer and mix them any way you desire. The basic modular controller consists of a rack, power supply, processor module (CPU), input/output (I/O modules), and an operator interface for programming and monitoring. The modules plug into a rack. When a module is slid into the rack, it makes an electrical connection with a series of contacts called the backplane, located at the rear of the rack. The PLC processor is also connected to the backplane and can communicate with all the modules in the rack.

The *power supply* supplies DC power to other modules that plug into the rack. For large PLC systems, this power supply does not normally supply power to the field devices. With larger systems, power to field devices is provided by external alternating current (AC) or direct current (DC) supplies. For some small micro-PLC systems, the power supply may be used to power field devices.

The *processor* (CPU) is the "brain" of the PLC. A typical processor usually consists of a microprocessor for implementing the logic and controlling the communications among the modules. The processor requires memory for storing the results of the logical operations performed by the microprocessor. Memory is also required for the program EPROM or EEPROM plus RAM. The CPU controls all PLC activity and is designed so that the user can enter the desired program in relay ladder logic. The PLC program is executed as part of a repetitive process referred to as a scan. A typical PLC scan starts with the CPU reading the status of inputs. Then, the application program is executed. Once the program execution is completed, the CPU performs internal diagnostic and communication tasks. Next, the status of all outputs is updated. This process is repeated continuously as long as the PLC is in the run mode.

The *I/O system* forms the interface by which field devices are connected to the controller. The purpose of this interface is to condition the various signals received from or sent to external field devices. Input devices such as pushbuttons, limit switches, and sensors are hardwired to the input terminals. Output devices such as small motors, motor starters, solenoid valves, and indicator lights are hardwired to the output terminals. To electrically isolate the internal components from the input and output terminals, PLCs commonly employ an optical isolator, which uses light to couple the circuits together.

A *programming device* is used to enter the desired program into the memory of the processor. The program can be entered using relay ladder logic, which is one of the most popular programming languages. Instead of words, ladder logic programming language uses graphic symbols that show their intended outcome.

A program in ladder logic is similar to a schematic for a relay control circuit. It is a special language written to make it easy for people familiar with relay logic control to program the PLC.

A personal computer (PC) is the most commonly used programming device. Most brands of PLCs have software available so that a PC can be used as the programming device. This software allows users to create, edit, document, store, and troubleshoot ladder logic programs. The computer monitor is able to display more logic on the screen than can hand-held types, thus simplifying the interpretation of the program. The personal computer communicates with the PLC processor via a serial or parallel data communications link, or Ethernet. If the programming unit is not in use, it may be unplugged and removed. Removing the programming unit will not affect the operation of the user program.

A *program* is a user-developed series of instructions that directs the PLC to execute actions. A *programming language* provides rules for combining the instructions so that they produce the desired actions.

Relay ladder logic (RLL) is the standard programming language used with PLCs. Its origin is based on electromechanical relay control. The relay ladder logic program graphically represents rungs of contacts, coils, and special instruction blocks. RLL was originally designed for easy use and understanding for its users and has been modified to keep up with the increasing demands of industry's control needs.

5.4 Application of PLC

There are three major types of PLC application: single ended, multitask, and control management.

A *single ended* or stand-alone PLC application involves one PLC controlling one process. This would be a stand-alone unit and would not be used for communicating with other computers or PLCs. The size and sophistication of the process being controlled are obvious factors in determining which PLC to select. The applications could dictate a large processor, but usually this category requires a small PLC.

A *multitask* PLC application involves one PLC controlling several processes. Adequate I/O capacity is a significant factor in this type of installation. In addition, if the PLC would be a subsystem of a larger process and would have to communicate with a central PLC or computer, provisions for a data communications network are also required.

A *control management* PLC application involves one PLC controlling several others. This kind of application requires a large PLC processor designed to

communicate with other PLCs and possibly with a computer. The control management PLC supervises several PLCs by downloading programs that tell the other PLCs what has to be done. It must be capable of connection to all the PLCs so that by proper addressing it can communicate with anyone it wishes to

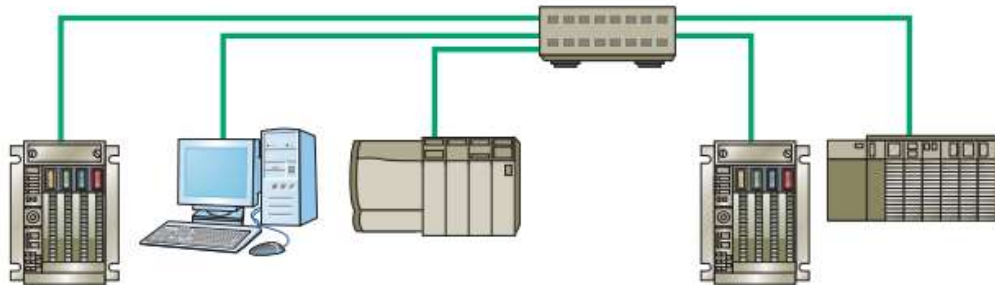

Figure 1-30 Control management PLC application.

Because of the versatility of PLC, it is used in various places for automation. In industries various processes needs to be controlled at every instant of time such as valve control, pressure control, robotic action, etc. It becomes tedious and infeasible for humans to control all such activities on their own. Thus, relays were used to perform those activities. However, a relay can be used only for a specific and limited operation which makes their use bulky and uneconomic. On the contrary PLC having the ability to perform number of tasks by simply modifying the program has become a prominent device for automation of such activities. There are various places where a PLC can be used. Some of those are listed as below:

- Robotic arm in car manufacturing
- Air compressors
- Airport runway lighting control
- Traffic signal control
- Smoke alarm control
- Process valve control
- Textile equipment
- Vacuum pump system

Apart from these applications, PLC is widely used in automation of electrical power system. At electrical substations automatic reclosing, circuit breaker tripping, capacitor switching, etc. can be controlled with PLCs.

5.5 Ladder diagram

- Lets use a PLC in place of the relay.
- The first thing that's necessary is to create what's called a **Ladder Diagram**.
- We have to create one of these because, unfortunately, a PLC doesn't understand a schematic diagram it only recognizes code.
- Most PLCs have software which convert ladder diagrams into code.

- **First Step** : Translate all of the items we're using into symbols the PLC understands.
- **Second step** : We must tell the PLC where everything is located. In other words we have to give all the devices an address.
- **Final step** : We have to convert the schematic into a logical sequence of events.

First step:

- The PLC doesn't understand terms like switch, relay, bell, etc.
- It prefers input, output, coil, contact, etc.
- It doesn't care what the actual input or output device actually is. It only cares that its an input or an output.
- First we replace the battery with a symbol. This symbol is common to all ladder diagrams. We draw what are called **bus bars**.
- These simply look like two vertical bars. One on each side of the diagram. Think of the left one as being + voltage and the right one as being ground. Further think of the current (logic) flow as being from left to right.
- Next we give the **inputs** a symbol. In this basic example we have one real world input. (i.e. the switch).
- We give the input that the switch will be connected to the symbol shown below. This symbol can also be used as the **contact of a relay**.



A contact symbol

- Next we give the **outputs** a symbol. In this example we use one output (i.e. the bell).
- We give the output that the bell will be physically connected to the symbol shown below. This symbol is used as the coil of a relay.

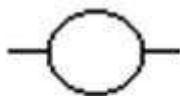

A coil symbol

- The AC supply is an external supply so we don't put it in our ladder. The PLC only cares about which output it turns on and not what's physically connected to it.

Second step:

- We must tell the PLC where everything is located. In other words we have to give all the devices an address.
- Where is the switch going to be physically connected to the PLC? How about the bell? We start with a blank road map in the PLC's town and give each item an address.
- Could you find your friends if you didn't know their address? You know they live in the same town but which house? The plc town has a lot of houses (inputs and outputs) but we have to figure out who lives where (what device is connected where).
- We'll get further into the addressing scheme later. The PLC manufacturers each do it a different way! For now let's say that our input will be called "0000". The output will be called "500".

Final step:

- Convert the schematic into a logical sequence of events.
- The program we're going to write tells the PLC what to do when certain events take place.
- In our example we have to tell the plc what to do when the operator turns on the switch.

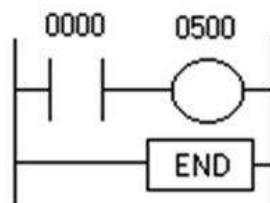

- Final converted diagram.
- We eliminated the real world relay from needing a symbol.

5.6 Description of contacts and coils in the following states

i) Normally open

Load :

- The load(LD) instruction is a **normally open contact**. It is sometimes also called examine if on (**XIO**).(as in examine the input to see if its physically on). The symbol for a load instruction is shown below.

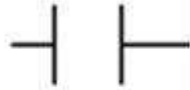

A Load (contact) symbol

- This is used when an input signal is needed to be present for the symbol to turn on.
- When the physical input is on we can say that the instruction is True.
- We examine the input for an on signal. If the input is physically on then the symbol is on.
- An on condition is also referred to as a logic 1 state.

ii) Normally closed

Load Bar :

- The Load bar instruction is a **normally closed contact**. It is sometimes also called LoadNot or examine if closed(**XIC**)(as in examine the input to see if its physically closed) The symbol for a loadbar instruction is shown below.



A LoadNot (normally closed contact) symbol

- This is used when an input signal does not need to be present for the symbol to turn on.
- When the **physical input is off** we can say that the **instruction is True**.
- We examine the input for an off signal. If the input is physically off then the symbol is on.
- With most PLCs this instruction (**Load** or **Loadbar**) **MUST** be the first symbol on the left of the ladder.

<u>Physical State</u>	<u>Instruction</u>	<u>Logic</u>
OFF	TRUE	0
ON	FALSE	1

iii) Energized output

out:

- The Out instruction is sometimes also called an **Output Energize instruction**. The output instruction is like a **relay coil**. Its symbol looks as shown below.
- When there is a path of True instructions preceding this on the ladder rung, it will also be True.

- When the **instruction is True it is physically ON.**
- We can think of this instruction as a normally open output.

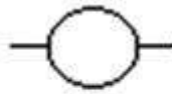

An OUT (coil) symbol

Output energize (OTE)

- Alternate name: coil
- This instruction is usually used in conjunction with **XIC** or **XIO** or any other input instruction.
- If the logic preceding the OTE instruction is true (1), the OTE instruction will be energized

Instruction symbol

An OTE instruction can **only** be the last instruction on a rung.

Not energized

Energized

iv) Latched output

Output latch (OTL)

- The OTL instruction is used only to turn a bit on and latch it on

Instruction symbol

Initially not energized

Energized

Latched

Out bar:

- The Outbar instruction is sometimes also called an OutNot instruction.
- The Outbar instruction is like a **normally closed relay coil**. Its symbol looks like that shown below.



An OUTBar (normally closed coil) symbol

5.7 Ladder diagrams

i) AND gate

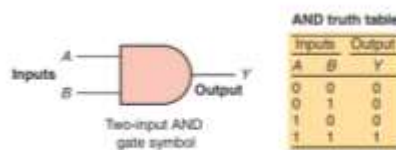

Figure 4-3 AND gate.

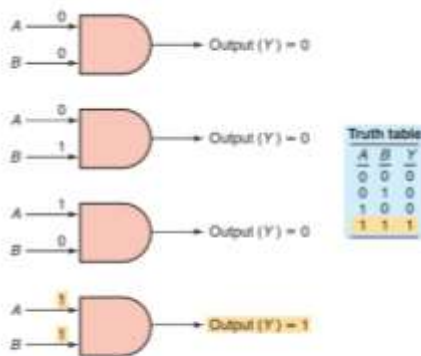

Figure 4-4 AND logic gate digital signal states.

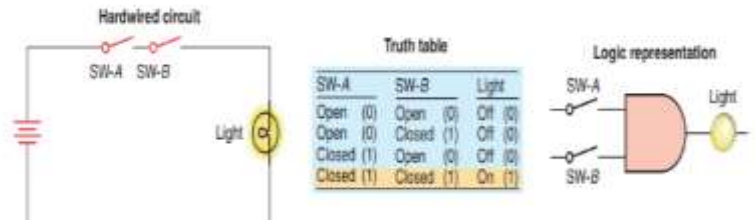
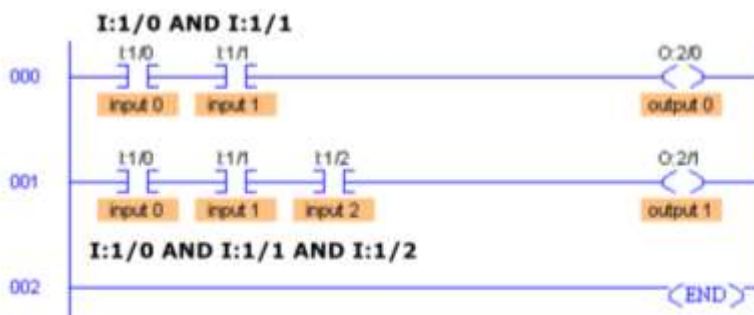

Figure 4-5 AND logic gate operates similarly to control devices connected in series.

Logical AND ladder diagram

- The logical AND function is constructed by series combinations of digital (discrete) inputs
 - Two (or more) series components



ii)OR gate

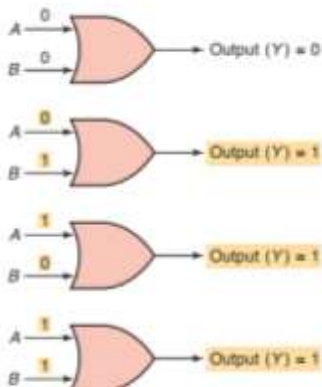

Figure 4-7 OR logic gate digital signal states.

Truth table		
Inputs		Output
A	B	Y
0	0	0
0	1	1
1	0	1
1	1	1

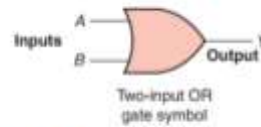
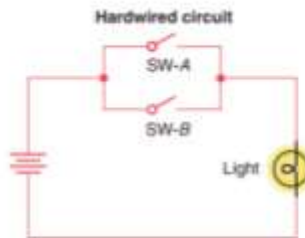

Figure 4-6 OR gate.

OR truth table		
Inputs		Output
A	B	Y
0	0	0
0	1	1
1	0	1
1	1	1



Truth table		
SW-A	SW-B	Light
Open (0)	Open (0)	Off (0)
Open (0)	Closed (1)	On (1)
Closed (1)	Open (0)	On (1)
Closed (1)	Closed (1)	On (1)

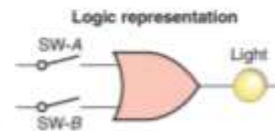
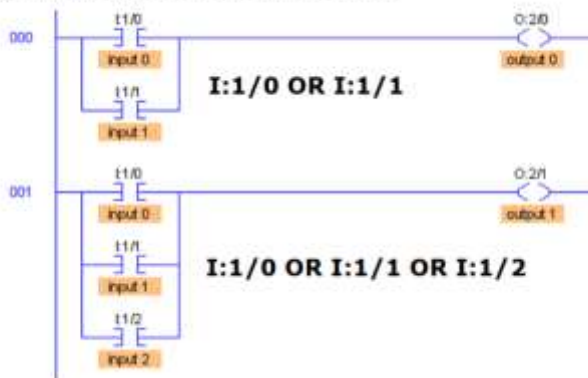

Figure 4-8 OR logic gate operates similarly to control devices connected in parallel.

Logical OR ladder diagram

- The logical OR function is constructed by parallel combinations of digital (discrete) inputs
 - Two (or more) parallel components



iii) NOT gate

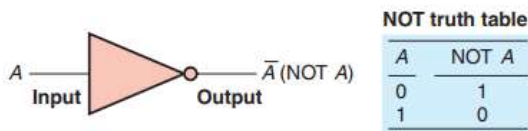

Figure 4-9 NOT function.

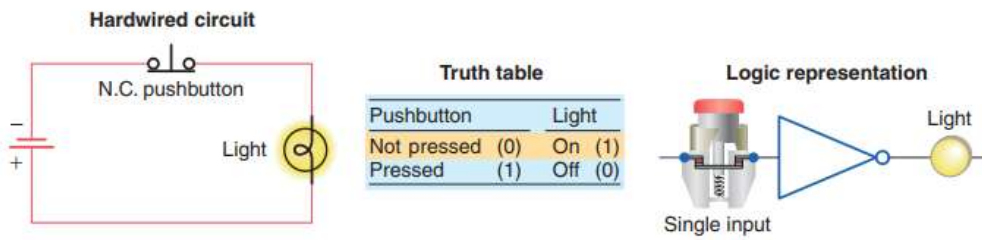
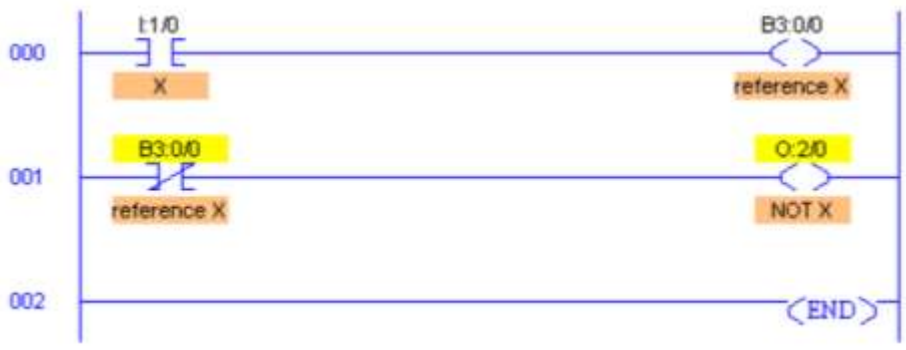

Figure 4-10 NOT function constructed using a normally closed pushbutton.







Logical NOT

- The logical NOT function is constructed by referencing the input signal with a normally closed contact (XIO instruction)

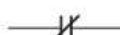
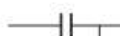
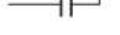
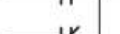

5.8 Ladder diagrams for combination circuits using NAND, NOR, OR and NOT

Table 4-1 Typical Boolean Instruction or Statement List

Boolean Instruction and Function	Graphic Symbol
Store (STR)–Load (LD) Begins a new rung or an additional branch in a rung with a normally open contact.	
Store Not (STR NOT)–Load Not (LD NOT) Begins a new rung or an additional branch in a rung with a normally closed contact.	
Or (OR) Logically ORs a normally open contact in parallel with another contact in a rung.	
Or Not (OR NOT) Logically ORs a normally closed contact in parallel with another contact in a rung.	
And (AND) Logically ANDs a normally open contact in series with another contact in a rung.	
And Not (AND NOT) Logically ANDs a normally closed contact in series with another contact in a rung.	
And Store (AND STR)–And Load (AND LD) Logically ANDs two branches of a rung in series.	
Or Store (OR STR)–Or Load (OR LOAD) Logically ORs two branches of a rung in parallel.	
Out (OUT) Reflects the status of the rung (on/off) and outputs the discrete (ON/OFF) state to the specified image register point or memory location.	
Or Out (OR OUT) Reflects the status of the rung and outputs the discrete (ON/OFF) state to the image register. Multiple OR OUT instructions referencing the same discrete point can be used in the program.	
Output Not (OUT NOT) Reflects the status of the rung and turns the output OFF for an ON execution condition; turns the output ON for an OFF execution condition.	

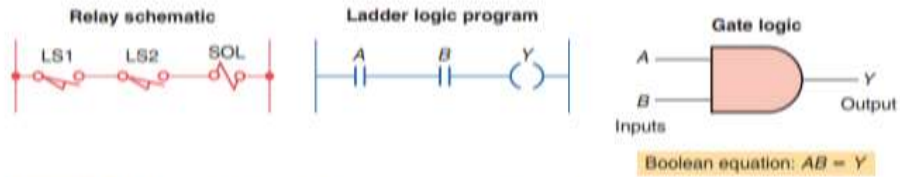

Example 4-1 Two limit switches connected in series and used to control a solenoid valve.

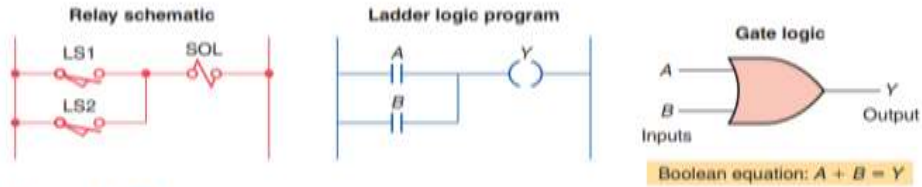

Example 4-2 Two limit switches connected in parallel and used to control a solenoid valve.

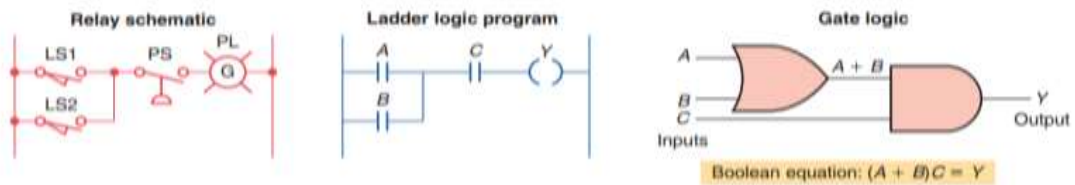

Example 4-3 Two limit switches connected in parallel with each other and in series with a pressure switch.

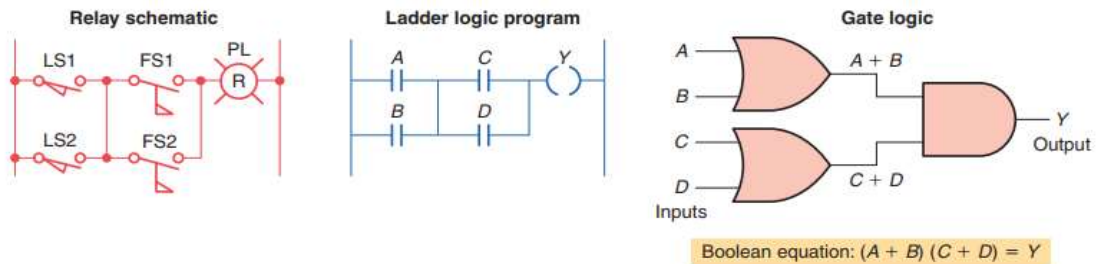

Example 4-4 Two limit switches connected in parallel with each other and in series with two sets of flow switches (that are connected in parallel with each other), and used to control a pilot light.

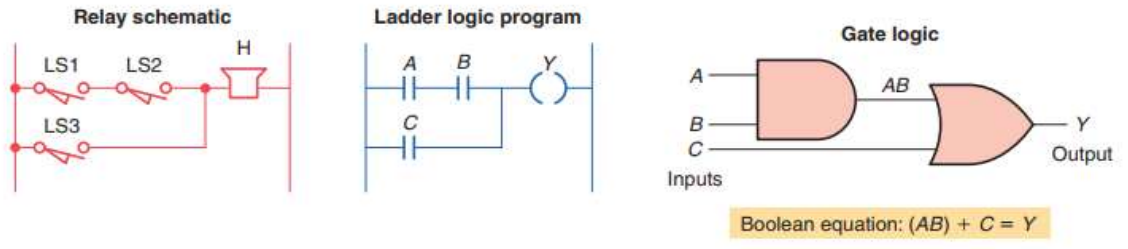

Example 4-5 Two limit switches connected in series with each other and in parallel with a third limit switch, and used to control a warning horn.

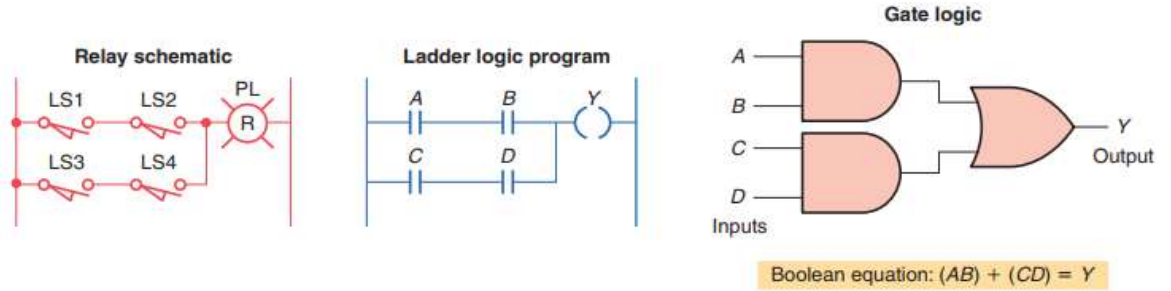

Example 4-6 Two limit switches connected in series with each other and in parallel with two other limit switches (that are connected in series with each other), and used to control a pilot light.

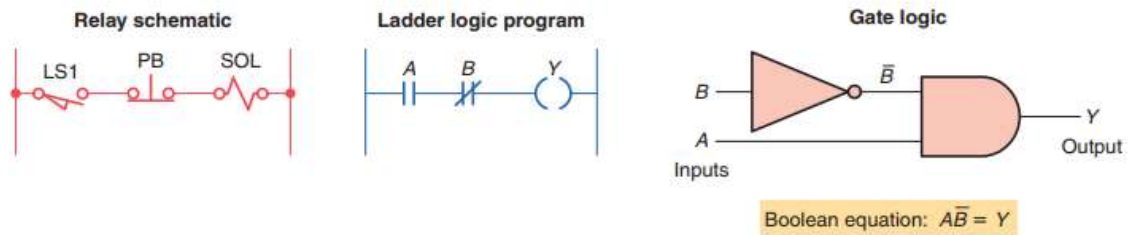

Example 4-7 One limit switch connected in series with a normally closed pushbutton and used to control a solenoid valve. This circuit is programmed so that the output solenoid will be turned on when the limit switch is closed and the pushbutton is *not pushed*.

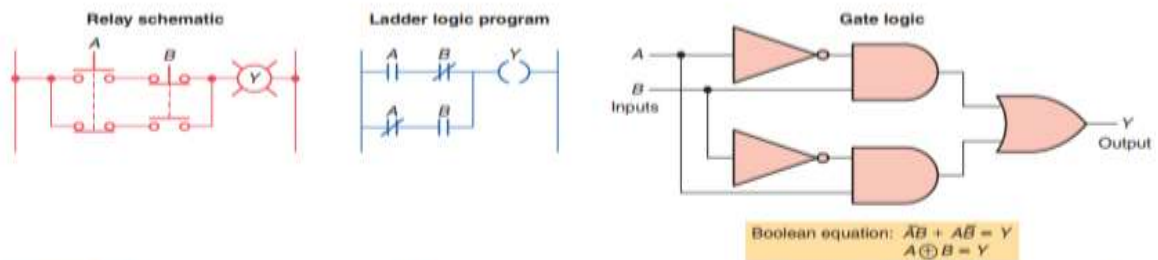

Example 4-8 Exclusive-OR circuit. The output lamp of this circuit is ON only when pushbutton A or B is pressed, but not both. This circuit has been programmed using only the normally open A and B pushbutton contacts as the inputs to the program.

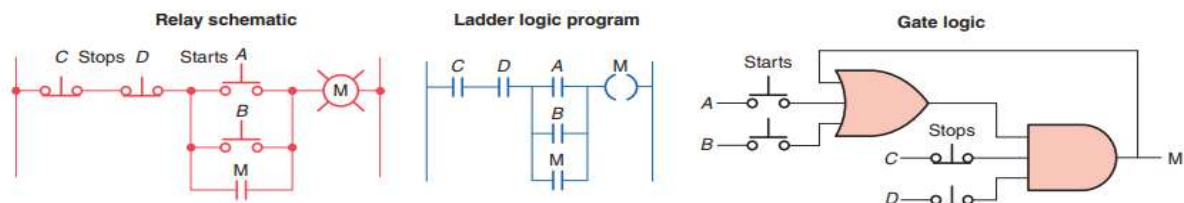

Example 4-9 A motor control circuit with two start/stop buttons. When either start button is depressed, the motor runs. By use of a seal-in contact, it continues to run when the start button is released. Either stop button stops the motor when it is depressed.

5.9 Timers

i) TON

- **TIMER** : It is an instruction that waits a set amount of time before doing something.

- Type of Timers : On-Delay Timer and Off-Delay Timer.

On-Delay Timer :

- Simply "delays turning on".
- After sensor (input) turns ON, wait x-seconds before activating a solenoid valve(output).
- This is the most common timer. It is often called **TON**(timer on-delay), **TIM**(timer) or **TMR**(timer).

Non-retentive Timers

- A single-input timer called a *non-retentive* timer is used in some PLCs.
 - Energizing I:1/0 causes the timer to run for 4 seconds.
 - At the end of 4 seconds the output (DN) goes on. When the input is de-energized, the output goes off and the timer resets to 0.
 - If the input I:1/0 is turned off during the timing interval (for example, after 2.7 seconds), the timer resets to 0.
 - **TON** is the basic non-retentive timer in Allen-Bradley PLCs



Timer Information

	/EN	/TT	/DN	.PRE	.ACC
T4:0	1	0	1	40	-40
T4:1	0	0	0	0	0
T4:2	0	0	0	0	0
T4:3	0	0	0	0	0
T4:4	0	0	0	0	0

Radix: Decimal Table: T4: Timer
Address: Symbol:

- The timer table contains all information for that timer
 - /EN: Timer is enabled (i.e. the input rung is energized)
 - /TT: Timer is timing
 - /DN: Timer is done
 - .PRE: Timer preset value (point at which the timer stops timing)
 - .ACC: Timer accumulator (accumulated time value)

ii) T OFF

Off-Delay Timer :

- Simply "delays turning off".
- After sensor (input) sees a target it turn on a solenoid (output).
- When the sensor no longer sees the target it hold the solenoid on for x-seconds before turning it off.
- It is called a TOF (timer off-delay).

Timer Delay Off (TOF)

- The TOF timer functions the opposite of the TON timer.
 - De-Energizing I:1/0 causes the timer to run for 4.5 seconds. The DN bit is initially set.
 - At the end of 4.5 seconds the output (DN) goes off. When the input is energized the timer resets to 0.
 - If the input I:1/0 is turned on during the timing interval (for example, after 2.7 seconds), the timer resets to 0.



iii) Retentive timer

Retentive Timers (RTO)

- Functions exactly like TON except the accumulated time value is retained even if the input rung is de-energized.

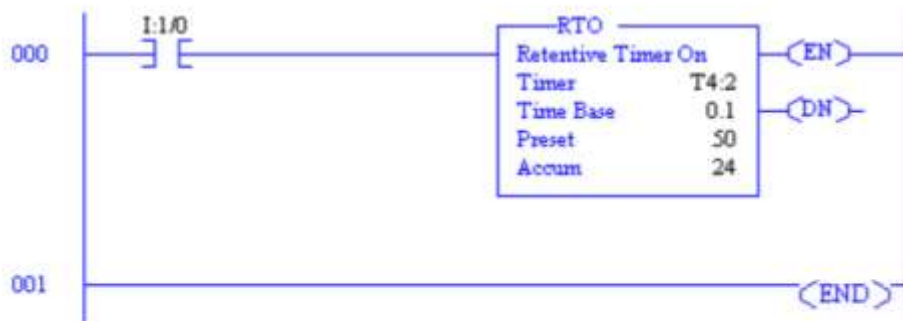

5.10 Counters

CTU

Up Counter (CTU)

- The CTU is an instruction that counts false-to-true rung transitions.
 - Rung transitions can be caused by events occurring in the program (from internal logic or by external devices) such as parts traveling past a detector or actuating a limit switch.
- When rung conditions for a CTU instruction have made a false-to-true transition, the accumulated value is incremented by one count, provided that the rung containing the CTU instruction is evaluated between these transitions.
 - The ability of the counter to detect false-to-true transitions depends on the speed (frequency) of the incoming signal.
- The accumulated value is retained when the rung conditions again become false.
- The accumulated count is retained until cleared by a reset (RES) instruction.

CTD

Down Counter (CTD)

- The CTD is an instruction that counts false-to-true rung transitions.
 - Rung transitions can be caused by events occurring in the program such as parts traveling past a detector or actuating a limit switch.
- When rung conditions for a CTD instruction have made a false-to-true transition, the accumulated value is decremented by one count, provided that the rung containing the CTD instruction is evaluated between these transitions.
- The accumulated counts are retained when the rung conditions again become false.
- The accumulated count is retained until cleared by a reset (RES) instruction.

5.11 Ladder diagram using Timers and Counters

Up Counter Example

- Accumulated count is reset only by the (RES) instruction
- The counter will increment the accumulator value even after the preset is reached



Down Counter Example

- Accumulated count is reset only by the (RES) instruction
- The counter will decrement the accumulator value even after a 0 count is reached



Ladder Logic Example

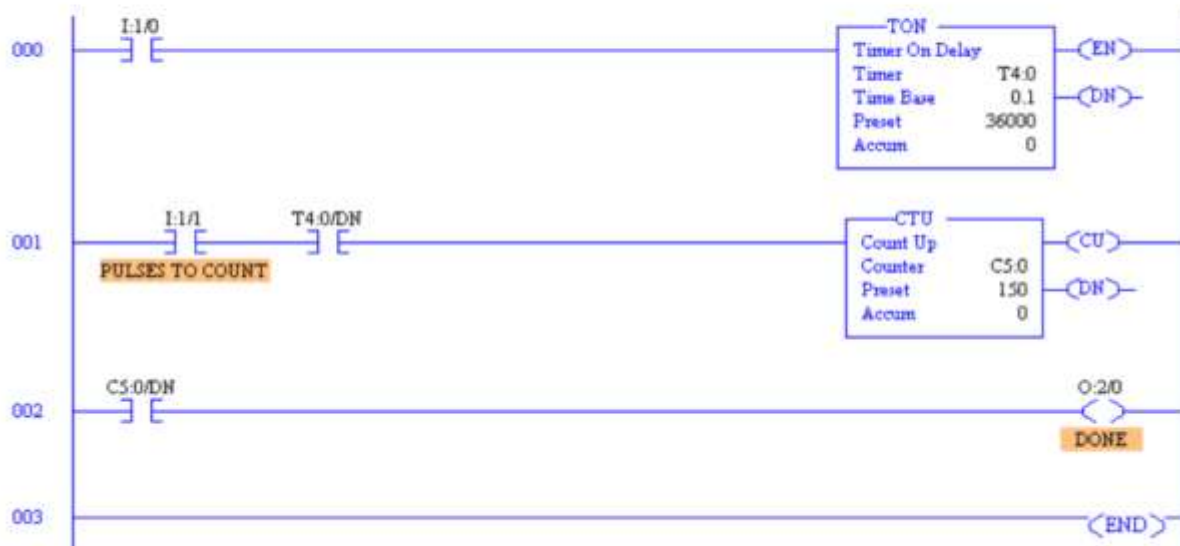

Ladder diagram for DOL starter

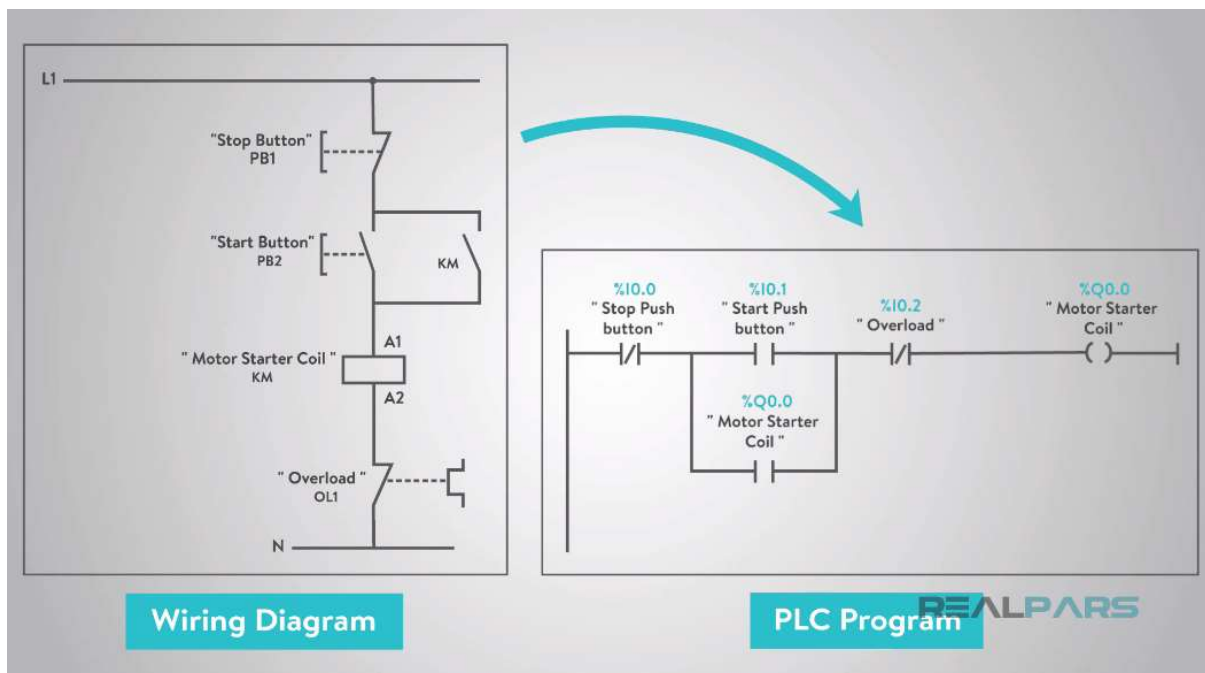

STAR-DELTA MOTOR STARTER LADDER LOGIC

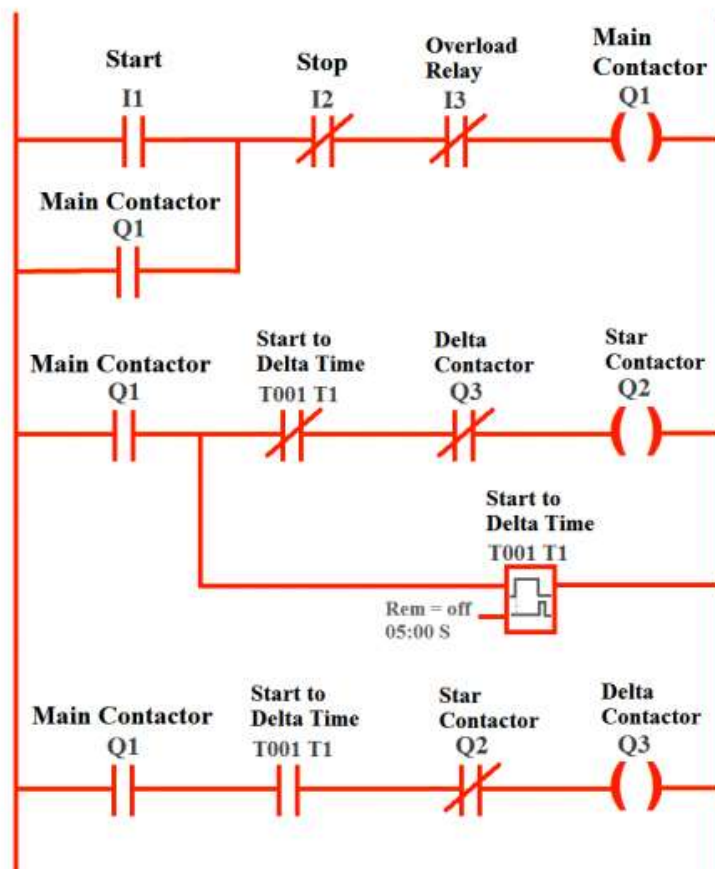

SPECIAL CONTROL SYSTEMS

DCS:

A distributed control system (DCS) is part of a manufacturing system.

Distributed control systems (DCS) are used in industrial and civil engineering applications to monitor and control distributed equipment with remote human intervention.

It is generally, since the 1970s, digital, and normally consists of field instruments, connected via wiring to computer buses or electrical buses to multiplexer/demultiplexers and A/D's or analog to digital and finally the Human-Machine Interface (HMI) or control consoles. A DCS is a process control system that uses a network to interconnect sensors, controllers, operator terminals and actuators. A DCS typically contains one or more computers for control and mostly use both proprietary interconnections and protocols for communications. See PAS.

DCS is a very broad term that describes solutions across a large variety of industries, including:

- * Electrical power grids and electrical generation plants
- * Environmental control systems
- * Traffic signals
- * Water management systems
- * Refining and chemical plants
- * Pharmaceutical manufacturing

SCADA:

SCADA is the acronym for Supervisory Control And Data Acquisition. SCADA may be called Human-Machine Interface (HMI) in Europe. The term refers to a large-scale, distributed measurement (and control) system. SCADA systems are used to monitor or to control chemical, physical or transport processes.

The three components of a SCADA system are:

1. Multiple Remote Terminal Units (also known as RTUs or Outstations).
2. Master Station and HMI Computer(s).
3. Communication infrastructure

Contents

- * 1 Systems concepts
- * 2 Human Machine Interface
- * 3 Hardware solutions
- * 4 System components
- * 5 Remote Terminal Unit (RTU)
- * 6 Master Station
- * 7 Operational philosophy
- * 8 Communication infrastructure and methods
- * 9 Future trends in SCADA
- * 10 Practical uses
- * 11 External links

The term SCADA usually refers to a central system that monitors and controls a complete site. The bulk of the site control is actually performed automatically by a Remote Terminal Unit (RTU) or by a Programmable Logic Controller (PLC). Host control functions are almost always restricted to basic site over-ride or supervisory level capability.

SCADA systems typically implement a distributed database which contains data elements called points. A point represents a single input or output value monitored or controlled by the system. Points can be either "hard" or "soft". A hard point is representative of an actual input or output connected to the system, while a soft point represents the result of logic and math operations applied to other hard and soft points. The point values are normally stored as value-timestamp combinations; the value and the timestamp when the value was recorded or calculated. A series of value-timestamp combinations is the history of that point.

DCS vs. SCADA

DCS and SCADA are monitoring and control mechanisms that are used in industrial installations to keep track and control of the processes and equipment; to ensure that everything goes smoothly, and none of the equipment work outside the specified limits. The most significant difference between the two is their general design. DCS, or Data Control System, is process oriented, as it focuses more on the processes in each step of the operation. SCADA, or Supervisory Control and Data Acquisition, focuses more on the acquisition and collation of data for reference of the personnel who are charged with keeping track of the operation.

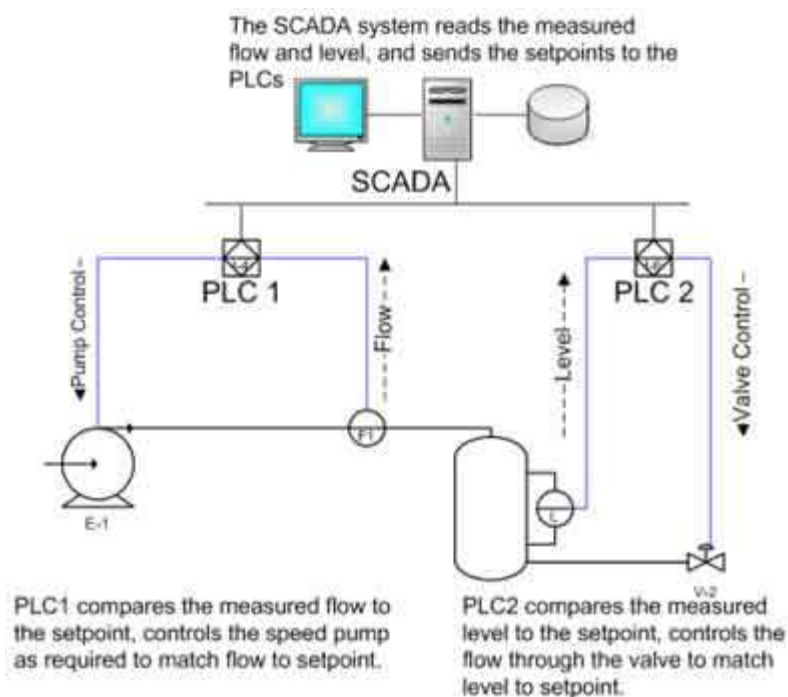

DCS is process state driven, while SCADA is event driven. DCS does all its tasks in a sequential manner, and events are not recorded until it is scanned by the station. In contrast, SCADA is event driven. It does not call scans on a regular basis, but waits for an event or for a change in value in one component to trigger certain actions. SCADA is a bit more advantageous in this aspect, as it lightens

the load of the host. Changes are also recorded much earlier, as an event is logged as soon as a value changes state.

In terms of applications, DCS is the system of choice for installations that are limited to a small locale, like a single factory or plant, while SCADA is preferred when the entire system is spread across a much larger geographic location, examples of which would be oil wells spread out in a large field. Part of the reason for this is the fact that DCS needs to be always connected to the I/O of the system, while SCADA is expected to perform even when field communications fail for some time. SCADA does this by keeping a record of all current values, so that even if the base station is unable to extract new information from a remote location, it would still be able to present the last recorded values.

Summary:

1. DCS is process oriented, while SCADA is data acquisition oriented.
2. DCS is process state driven, while SCADA is event driven.
3. DCS is commonly used to handle operations on a single locale, while SCADA is preferred for applications that are spread over a wide geographic location.